

# **ANALYSIS OF DRIVING BEHAVIOR AT EXPRESSWAY TOLL PLAZAS USING DRIVING SIMULATOR**

by

MOATZ SAAD

B.S. Alexandria University, 2012

A thesis submitted in partial fulfillment of the requirements  
for the degree of Master of Science  
in the Department of Civil and Environmental Engineering  
in the College of Engineering and Computer Science  
at the University of Central Florida  
Orlando, Florida

Fall Term

2016

Major Professor: Mohamed A. Abdel-Aty

© 2016 Moatz Saad

## **ABSTRACT**

The objective of this study is to analyze the driving behavior at toll plazas by examining multiple scenarios using a driving simulator to study the effect of different options including different path decisions, various signs, arrow markings, traffic conditions, and extending auxiliary lanes before and after the toll plaza on the driving behavior. Also, this study focuses on investigating the effect of drivers' characteristics on the dangerous driving behavior (e.g. speed variation, sudden lane change, drivers' confusion). Safety and efficiency are the fundamental goals that transportation engineering is always seeking for the design of highways. Transportation agencies have a crucial challenging task to accomplish traffic safety, particularly at the locations that have been identified as crash hotspots. In fact, toll plaza locations are one of the most critical and challenging areas that expressway agencies have to pay attention to because of the increasing traffic crashes over the past years near toll plazas.

Drivers are required to make many decisions at expressway toll plazas which result in drivers' confusion, speed variation, and abrupt lane change maneuvers. These crucial decisions are mainly influenced by three reasons. First, the limited distance between toll plazas and the merging areas at the on-ramps before the toll plazas. In addition to the limited distance between toll plazas and the diverging areas after the toll plazas at the off-ramps. Second, it is also affected by the location and the configuration of signage and pavement markings. Third, drivers' decisions are affected by the different lane configurations and tolling systems that can cause drivers' confusion and stress. Nevertheless, limited studies have explored the factors that influence driving behavior and safety at toll plazas. There are three main systems of the toll plaza, the traditional mainline toll plaza (TMTP), the hybrid mainline toll plaza (HMTP), and the all-electronic toll collection

(AETC). Recently, in order to improve the safety and the efficiency of the toll plazas, most of the traditional mainline toll plazas have been converted to the hybrid toll plazas or the all-electronic toll collection plazas. This study assessed driving behavior at a section, including a toll plaza on one of the main expressways in Central Florida. The toll plaza is located between a close on-ramp and a nearby off-ramp. Thus, these close distances have a significant effect on increasing driver's confusion and unexpected lane change before and after the toll plaza.

Driving simulator experiments were used to study the driving behavior at, before and after the toll plaza. The details of the section and the plaza were accurately replicated in the simulator. In the driving simulator experiment, Seventy-two drivers with different age groups were participated. Subsequently, each driver performed three separate scenarios out of a total of twenty-four scenarios. Seven risk indicators were extracted from the driving simulator experiment data by using MATLAB software. These variables are average speed, standard deviation of speed, standard deviation of lane deviation, acceleration rate, standard deviation of acceleration (acceleration noise), deceleration rate, and standard deviation of deceleration (braking action variation). Moreover, various scenario variables were tested in the driving simulator including different paths, signage, pavement markings, traffic condition, and extending auxiliary lanes before and after the toll plaza. Drivers' individual characteristics were collected from a questionnaire before the experiment. Also, drivers were filling a questionnaire after each scenario to check for simulator sickness or discomfort. Nine variables were extracted from the simulation questionnaire for representing individual characteristics including, age, gender, education level, annual income, crash experience, professional drivers, ETC-tag use, driving frequency, and novice international drivers.

A series of mixed linear models with random effects to account for multiple observations from the same participant were developed to reveal the contributing factors that affect driving behavior at toll plazas. The results uncovered that all drivers who drove through the open road tolling (ORT) showed higher speed and lower speed variation, lane deviation, and acceleration noise than other drivers who navigate through the tollbooth. Also, the results revealed that providing adequate signage, and pavement markings are effective in reducing risky driving behavior at toll plazas. Drivers tend to drive with less lane deviation and acceleration noise before the toll plaza when installing arrow pavement markings. Adding dynamic message sign (DMS) at the on-ramp has a significant effect on reducing speed variation before the toll plaza. Likewise, removing the third overhead sign before the toll plaza has a considerable influence on reducing aggressive driving behavior before and after the toll plaza. This result may reflect drivers' desire to feel less confusion by excessive signs and markings. Third, extending auxiliary lanes with 660 feet (0.125 miles) before or after the toll plaza have an effect on increasing the average speed and reducing the lane deviation and the speed variation at and before the toll plaza. It also has an impact on increasing the acceleration noise and the braking action variation after the toll plaza. Finally, it was found that in congested conditions, participants drive with a lower speed variation and lane deviation before the toll plaza but with a higher acceleration noise after the toll plaza. On the other hand, understanding drivers' characteristics is particularly important for exploring their effect on risky driving behavior. Young drivers (18-25) and old drivers (older than 50 years) consistently showed a higher risk behavior than middle age drivers (35 to 50). Also, it was found that male drivers are riskier than female drivers at toll plazas. Drivers with high education level, drivers with high income, ETC-tag users, and drivers whose driving frequency is less than three trips per day are more cautious and tend to drive at a lower speed.

## **ACKNOWLEDGMENTS**

I would like to express my thanks to my thesis committee members, Dr. Aty, Dr. Lee, and Dr. Eluru, for their effort and support in this research. In particular, I would like to acknowledge my advisor, Dr. Moahmed Abdel-Aty, for helping me improving my way of thinking and for his excellent guidance and effort on my research. Gratitude is also expressed to Dr. Jaeyoung Lee for the countless help to me and providing guidance, especially in statistical approaches.

Additionally, I would like to acknowledge Kali Carroll, Yina Wu, and Qing Cai for their effort in conducting the driving simulator experiments and providing experiment's videos. Also want to thank Dr. Qi Shi for helping in the experiment design procedure.

I also would like to thank the transportation research team at the University of Central Florida for sharing their valuable ideas with me and for their support: Dr. Ling Wang, Dr. Junghan Wang, Dr. Juneyoung Park, Whoi-bin Chung, Ahmed Farid, Samer Alamili, Md Imran Shah, Saif Alarifi, Khalid Alkahtani and Claudia Bustamante. Also, I would like to thank my family and my friends for their encouragement and support.

Finally, I would like to thank the University of Central Florida, College of Graduate Studies for their continuous help and support.

## TABLE OF CONTENTS

LIST OF FIGURES .....	x
LIST OF TABLES .....	xiv
LIST OF ABBREVIATIONS.....	xvi
CHAPTER 1. INTRODUCTION .....	1
1.1 Overview .....	1
1.2 Dean Mainline Toll Plaza Safety .....	6
1.3 Research Objectives .....	8
1.4 Thesis Organization.....	8
CHAPTER 2. LITERATURE REVIEW .....	11
2.1 Traffic Simulation .....	11
2.2 Toll Plaza Safety .....	12
CHAPTER 3. VALIDATION OF THE DRIVING SIMULATOR STUDY.....	18
3.1 Background .....	18
3.2 Statistical Approach for Driving Simulator Validation.....	19
CHAPTER 4. DATA PREPARATION.....	21
4.1 Data Collection.....	21
4.2 Study Area.....	22
4.3 The Driving Simulator .....	25
4.4 Using MATLAB software for Extracting Data from the Driving Simulator .....	27
4.5 Driving Simulator Experiment Videos.....	31
CHAPTER 5. EXPERIMENTAL DESIGN.....	32
5.1 Driving simulator experimental design.....	32
5.2 Testing similarity between the driving simulation samples and the real world population	34
5.3 Simulator sickness.....	36
5.4 Scenario Variables.....	37

5.4.1 Path .....	38
5.4.2 Signage .....	39
5.4.3 Extending Auxiliary Lanes .....	41
5.4.4 Pavement Markings .....	42
5.4.5 Traffic Conditions.....	43
5.5 Driver Characteristics.....	44
5.6 Driving Behavior.....	46
5.6.1 Average Speed.....	48
5.6.2 Lane deviation .....	49
5.6.3 Acceleration noise .....	50
5.6.4 Testing normality of the variables .....	51
5.6.4.1 Testing Normality for Average Speed Variable .....	51
5.6.4.2 Testing Normality for Standard Deviation of Speed Variable.....	53
5.6.4.3 Testing Normality for the Standard Deviation of Lane Deviation Variable.....	55
5.6.4.4 Testing Normality for Acceleration Variable .....	56
5.6.4.5 Testing Normality for Acceleration Noise Variable.....	59
5.6.4.6 Testing Normality for Deceleration Variable .....	61
5.6.4.7 Testing Normality for Standard Deviation of Deceleration Variable.....	64
CHAPTER 6. STATISTICAL METHODOLOGY .....	67
CHAPTER 7. MODELING RESULTS AND DISCUSSION .....	69
7.1 The Linear mixed model results.....	69
7.1.1 Average Speed Model results .....	71
7.1.2 Log Standard deviation of Speed Model results.....	75
7.1.3 Standard Deviation of Lane Deviation Model results .....	79
7.1.4 Log Acceleration Noise Model results .....	82
7.1.5 Log Acceleration Model results .....	86
7.1.6 Log Deceleration Model results .....	90
7.1.7 Log Standard Deviation of Deceleration Model results .....	93
7.2 Discussion .....	96
7.2.1 Scenario Variables.....	96



7.2.2 Driver Characteristics .....	97
CHAPTER 8. CONCLUSIONS AND RECOMMENDATIONS .....	99
8.1 Conclusions .....	99
8.2 Contributions and Recommendations .....	100
8.3 Further Research .....	101
APPENDIX A: SIMULATOR QUESTIONNAIRE .....	102
APPENDIX B: FIGURES AND TABLES.....	110
LIST OF REFERENCES .....	174

## LIST OF FIGURES

Figure 1. Traditional Mainline Toll Plaza (Source: FHWA).....	2
Figure 2. Example of the ETC-Tag (Source: E-ZPass) .....	2
Figure 3. ETC system at the TMTP (Source: ITS Deployment Progress in Japan) .....	3
Figure 4. All-Electronic Toll Collection (AETC) (Source: FHWA, Abuzwidah, 2014).....	3
Figure 5. ETC system at the ORT (Source: Massachusetts Department of Transportation).....	4
Figure 6. Hybrid Mainline Toll Plaza (HMTP) (Source: Central Florida Expressway Authority, Abuzwidah, 2014).....	4
Figure 7. The Expected Crash Location at Gore Areas (Source: Abuzwidah, 2011).....	5
Figure 8. Location of Crashes at Dean Mainline Toll Plaza-Eastbound (Abuzwidah, 2011) .....	7
Figure 9. Location of Crashes at Dean Mainline Toll Plaza-Westbound (Abuzwidah, 2011).....	7
Figure 10. Flow Chart of Thesis sequence.....	10
Figure 11. Electronic Tolling using ITS technique (Source: USDOT) .....	13
Figure 12. ETC at HOT lanes (Source: The Transit Coalition).....	14
Figure 13. Toll Plaza Scenarios (Source: McKinnon, 2013).....	15
Figure 14. Possible Conflict Points at a TMTP (Source: Abdelwahab and Abdel-Aty, 2002) ....	16
Figure 15. Location of the Five Detectors Used for Validation (Source: Google Earth) .....	19
Figure 16. Average Speed Comparison between the Field and the Simulation Experiment at each location.....	20
Figure 17. The Dean Mainline Toll Plaza (Source: Google Earth) .....	22
Figure 18. Toll Plazas at Orlando-Orange County Expressways (Source: CFX, and Abuzwidah, 2011) .....	23
Figure 19. Florida State Road Network (Source: FDOT, and Abuzwidah, 2011).....	24

Figure 20. Dean Road Mainline Toll Plaza Design (Source: CFX, and Abuzwidah, 2011) .....	24
Figure 21. Location of the Four Zones at SR-408 (Source: Google Earth).....	25
Figure 22. UCF Driving Simulator .....	26
Figure 23. Driving Simulator Experiment at UCF.....	26
Figure 24. DaqViewer interface for extracting simulator data .....	28
Figure 25. DaqSelector interface at MATLAB software.....	29
Figure 26. Example of a Speed Profile for an Experiment .....	30
Figure 27. Example of Lane Deviation for an Experiment.....	30
Figure 28. Example of the Four Views of the Experiment videos.....	31
Figure 29. Experimental Design Flow Chart .....	33
Figure 30. Percentages of Male and Female Participants in each Age Group from The Driving Simulator Data .....	35
Figure 31. Percentages of Male and Female Participants in each Age Group from Real World data.....	36
Figure 32. Path Cases.....	38
Figure 33. Signage Cases .....	39
Figure 34. Overhead Sign (Source: Google Earth).....	40
Figure 35. Portable DMS in the Simulator .....	40
Figure 36. Example of Guide Signage Locations for the Hybrid Toll Plaza (Source: MUTCD 2009) .....	41
Figure 37. Arrow Pavement Markings (Source: Google Earth) .....	42
Figure 38. Pavement Markings Case .....	42
Figure 39. Average Speed Histogram.....	48

Figure 40. Lane Deviation Profile for Participant 52 Scenario 8 .....	49
Figure 41. Speed Profile for Participant 1 Scenario 10 .....	51
Figure 42. Average Speed Histogram.....	52
Figure 43. Standard Deviation of Speed Histogram .....	53
Figure 44. Log Standard Deviation of Speed Histogram.....	55
Figure 45. Standard Deviation of Lane Deviation Histogram .....	56
Figure 46. Acceleration Histogram.....	57
Figure 47. Log Acceleration Histogram .....	58
Figure 48. Acceleration Noise Histogram .....	59
Figure 49. Log Acceleration Noise Histogram.....	61
Figure 50. Deceleration Histogram.....	62
Figure 51. Log Deceleration Histogram .....	63
Figure 52. Standard Deviation of Deceleration Histogram .....	64
Figure 53. Log Standard Deviation of Deceleration Histogram.....	66
Figure 54. Box Plot of the Relation between Average Speed at each Zone for each Path.....	74
Figure 55. Box Plot of the Relation between Log Standard Deviation of Speed at each Zone for each Path.....	78
Figure 56. Box Plot of the Relation between the Standard Deviation of Lane Deviation at each Zone for each Path .....	81
Figure 57. Relation between Log Acceleration Noise at each Zone for each Path .....	85
Figure 58. Relation between Log Acceleration at each Zone for each Path.....	89
Figure 59. Relation between Log Deceleration at each Zone for each Path.....	92

Figure 60. Relation between Log Standard Deviation of Deceleration at each Zone for each Path

..... 95

## LIST OF TABLES

Table 1. Tolling systems (Source: McKinnon, 2013).....	13
Table 2. Comparing Field Data and Driving Simulator Data for each Location .....	20
Table 3. Comparing Number of Drivers between Simulator Experiment and Real world.....	35
Table 4. Description of experiment Scenarios.....	37
Table 5. Descriptive Statistics of Scenario Variables.....	43
Table 6. Descriptive Statistics for Driver Characteristics.....	45
Table 7. Descriptive Statistics for Driving Behavior Variables .....	47
Table 8. Descriptive statistics of Average Speed for each zone .....	48
Table 9. Kolmogorov-Smirnov results for Average Speed .....	52
Table 10. Kolmogorov-Smirnov results for Standard Deviation of Speed.....	53
Table 11. Kolmogorov-Smirnov results for Log Standard Deviation of Speed .....	54
Table 12. Kolmogorov-Smirnov results for Standard Deviation of Lane Deviation.....	55
Table 13. Kolmogorov-Smirnov results for Acceleration .....	56
Table 14. Kolmogorov-Smirnov results for Log Acceleration.....	58
Table 15. Kolmogorov-Smirnov results for Acceleration Noise .....	59
Table 16. Kolmogorov-Smirnov results for Log Acceleration Noise.....	60
Table 17. Kolmogorov-Smirnov results for Deceleration .....	61
Table 18. Kolmogorov-Smirnov results for Log Deceleration.....	63
Table 19. Kolmogorov-Smirnov results for Standard Deviation of Deceleration .....	64
Table 20. Kolmogorov-Smirnov results for Log Standard Deviation of Deceleration.....	65
Table 21. Average Speed Model for Each Zone.....	73
Table 22. Log Standard Deviation of Speed Model for Each Zone.....	77

Table 23. Standard Deviation of Lane Deviation Model for Each Zone .....	80
Table 24. Log Acceleration Noise Model for Each Zone .....	84
Table 25. Log Acceleration Model for Each Zone .....	88
Table 26. Log Deceleration Model for Each Zone .....	91
Table 27. Log Standard Deviation of Deceleration Model for Each Zone .....	94

## **LIST OF ABBREVIATIONS**

ACM	Automatic Coin Machine
AETC	All-Electronic Toll Collection
AIC	Akaike Information Criterion
CARS	Crash Analysis Reporting System
CFX	Central Florida Expressway Authority
DDI	Diverging Diamond Interchange
DMS	Dynamic Message Sign
ETC	Electronic Toll Collection
FDOT	Florida Department of Transportation
FT	Feet
HMTP	Hybrid Mainline Toll Collection
HOT	High-Occupancy Toll Lanes
IRB	Institutional Review Board
ISAT	Interactive Scenario Authoring Tools
MPH	Mile Per Hour
MUTCD	Manual of Uniform on Traffic Control Devices



MVDS	Microwave Vehicle Detection System
NADS	National Advanced Driving Simulator
TMT	Tile Mosaic Tool
TMTP	Traditional Mainline Toll Plaza
TRB	Transportation Research Board
UCF	University of Central Florida
VMS	Variable Message Sign

# CHAPTER 1. INTRODUCTION

## 1.1 Overview

Safety and efficiency are the fundamental goals that transportation engineers are always seeking on highways. Transportation agencies have a crucial challenging task to accomplish traffic safety, particularly at the locations that have been identified as crash hotspots. In fact, toll plaza locations are one of the most critical and challenging areas that expressway agencies have to pay attention to. Over the past decade, toll plaza systems have been increased and attempts have been devoted to reduce collisions at toll plazas (Abuzwidah, 2014). Between 2010 and 2012, rear-end and sideswipe crashes were the majority of the traffic crashes at toll plazas (McKinnon, 2013). According to Abuzwidah and Abdel-Aty (2015), there are three main types of toll plaza's designs. First, the traditional mainline toll plazas (TMTP) as shown in Figure 1, which have cash lanes and express lanes through a tollbooth. This design requires vehicles to decelerate so drivers can navigate through different fare options include cash toll system and electronic toll collection system (ETC). Electronic toll collection tag (ETC-tag), as shown in Figure 2, is used in the express lanes for collecting tolls automatically (Figure 3). Second, the all-electronic toll collection (AETC) system, as illustrated in Figure 4, which have express lanes through an open road tolling (ORT). This design does not have a tollbooth or barrier, so it is similar to the normal segments. Thus, drivers can navigate through express lanes without stopping to pay tolls or change lanes by using the automatic vehicle identification (AVI) transponders. Figure 5 shows the ETC system at the ORT. This system is distinguished as an important Intelligent Transportation System (ITS) application. Third, the hybrid mainline toll plazas (HMTP) which combine both tollbooth and the open road tolling system (Figure 6).



Figure 1. Traditional Mainline Toll Plaza (Source: FHWA)



Figure 2. Example of the ETC-Tag (Source: E-ZPass)

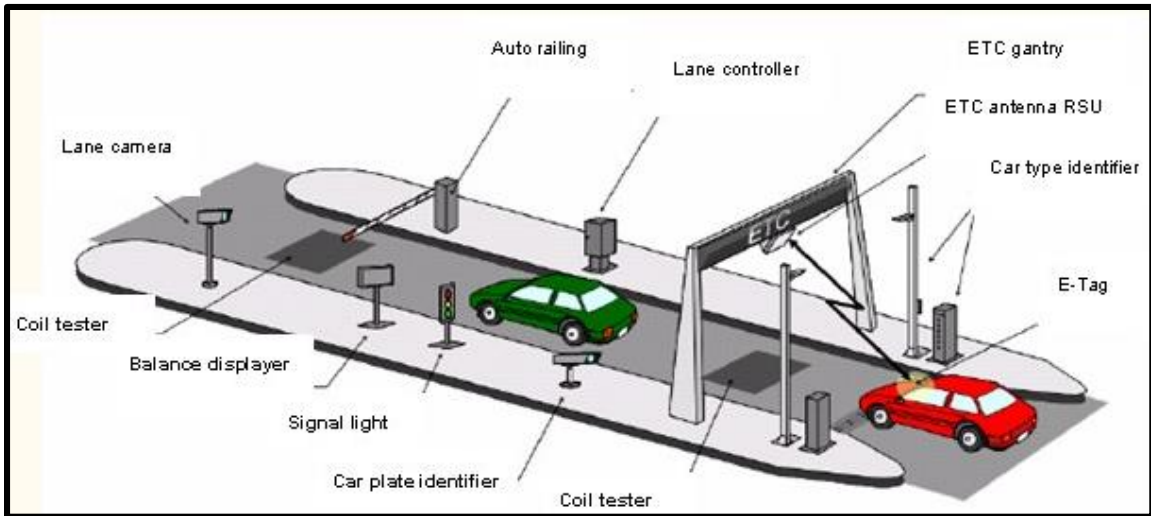

Figure 3. ETC system at the TMTP (Source: ITS Deployment Progress in Japan)

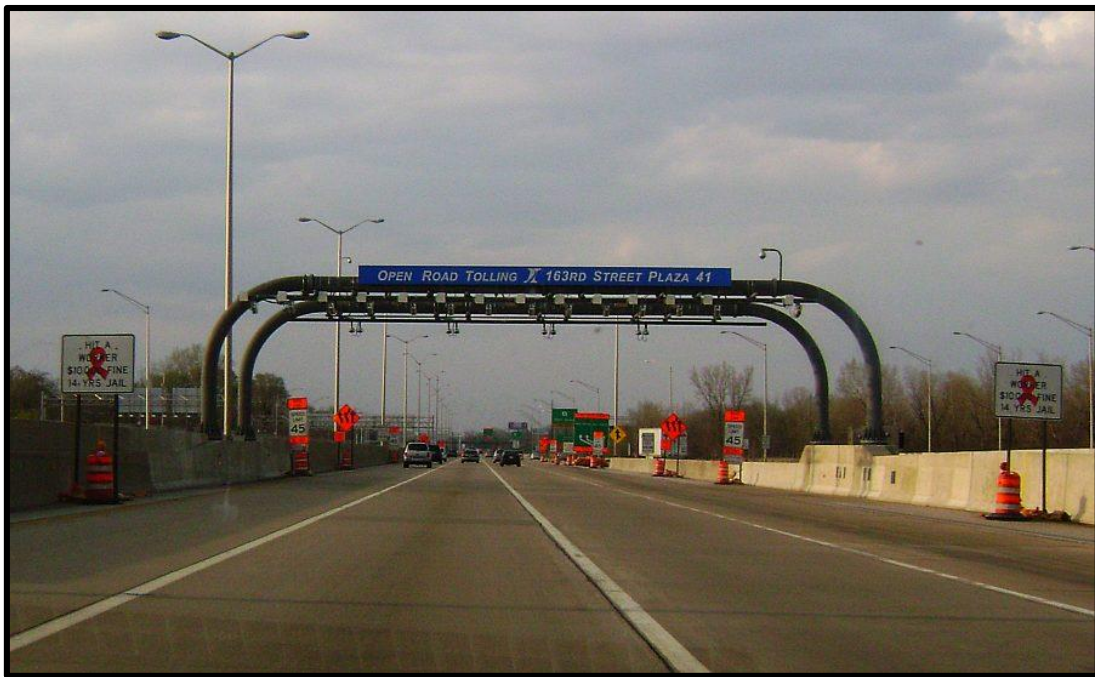

Figure 4. All-Electronic Toll Collection (AETC) (Source: FHWA, Abuzwidah, 2014)

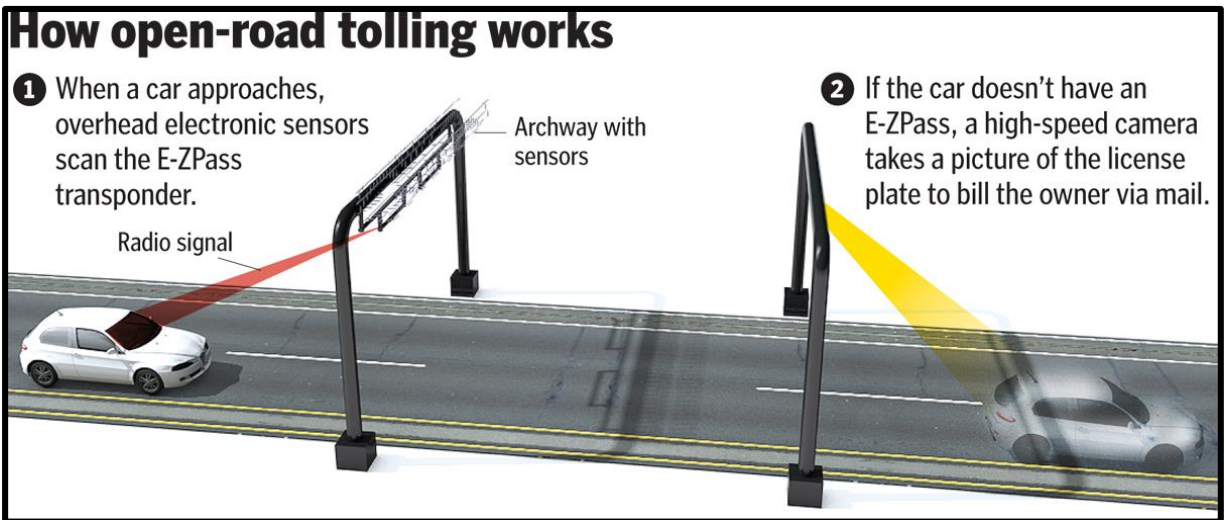

Figure 5. ETC system at the ORT (Source: Massachusetts Department of Transportation)



Figure 6. Hybrid Mainline Toll Plaza (HMTP) (Source: Central Florida Expressway Authority, Abuzwidah, 2014)

The substantial problem identified at the hybrid toll plazas is that drivers have to make many critical decisions before, at, and after toll plazas. Drivers' decisions are fundamentally affected by three main reasons. First, the limited distance between toll plazas and gore areas, which is the merging areas after the on-ramps and the diverging areas before the off-ramps, negatively

affects drivers' decisions since drivers suffer from sudden unexpected lane change before and after toll plazas (Carroll, 2016). Also, it was found that diverging areas before the toll plazas, as shown in Figure 7, had 82% higher risk of traffic crashes than merging areas after toll plazas (Abuzwidah, 2011). Additionally, it was found that most severe crashes occur before and after toll plazas at gore areas (Abuzwidah and Abdel-Aty, 2015).

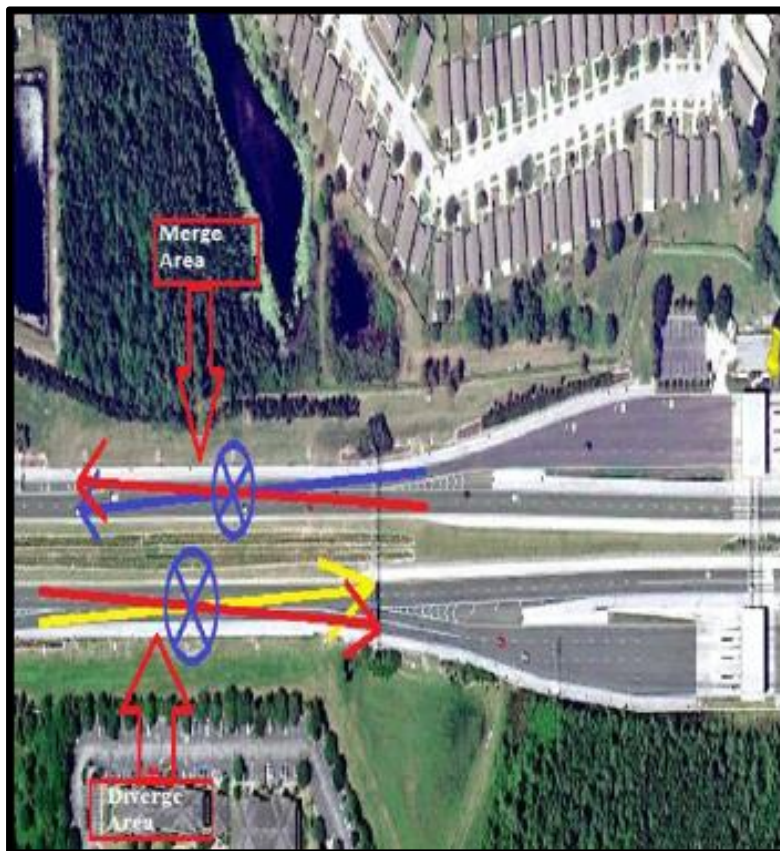

Figure 7. The Expected Crash Location at Gore Areas (Source: Abuzwidah, 2011)

Second, drivers' decisions are influenced by signs and pavement markings which have different standards for each toll plaza agency (McKinnon, 2013; Carroll, 2016; Rephlo et al., 2010). For example, Toll highway agencies designate cash and electronic toll collection (ETC) lanes by

providing signs or pavement markings (e.g. CASH ONLY, ETC-TAG). However, their designs of such signs and pavement markings may not be consistent. It was recommended that proper signage should be provided to reduce drivers' confusion and improve driving experience (Abdelwahab and Abdel-Aty, 2002; McKinnon, 2013; Carroll, 2016). The erroneous location of signage may cause traffic crashes due to the abrupt lane changing so drivers may lose control near toll plazas (Abuzwidah, 2011). Third, drivers' critical decisions are also affected by the various lane configurations and tolling systems that can make drivers confused and stressed (McKinnon, 2013; Carroll, 2016; Brown et al., 2006; Mohamed et al., 2001)).

### 1.2 Dean Mainline Toll Plaza Safety

This study focuses on studying the driving behavior at a toll plaza, the Dean Mainline Toll Plaza, which is located on state road (SR-408) in Orlando, Florida. Drivers who drove through this toll plaza experience confusion and sudden lane change due to its location between a close on-ramp and a nearby off-ramp. According to Abuzwidah (2011), from the crash reports, the location of the crashes along the Dean Mainline Toll Plaza in the eastbound direction is shown in Figure 8. Likewise, the location of the crashes along the Dean Mainline Toll Plaza at the westbound direction is shown in Figure 9. It can be concluded from the figures that the most dangerous locations along the toll plaza segment are the merging and the diverging areas. The crash reports illustrated that the most frequent types of traffic crashes at these locations are the sideswipe and the lost control crashes. These two categories of traffic crashes are mainly because of the sudden lane changing and the unexpected weaving maneuvers at these sites. That is why the main object of this study is exploring the driving risk behavior before, at, and after the Dean Mainline Toll Plaza.



Figure 8. Location of Crashes at Dean Mainline Toll Plaza-Eastbound (Abuzwidah, 2011)



Figure 9. Location of Crashes at Dean Mainline Toll Plaza-Westbound (Abuzwidah, 2011)



### 1.3 Research Objectives

The main purpose of this study is to assess traffic safety through toll plazas by exploring the risky driving behavior before, at, and after the toll plaza. Also, study how does driving behavior change for different locations along the toll plaza area. Multiple driver simulator scenarios were evaluated in an endeavor to identify the most critical factors that contribute to driving behavior at toll plazas considering drivers' characteristics. To achieve this goal, a series of mixed linear regression models with random effects were developed to analyze the factors that affect risk behavior at toll plazas (before, at, and after) on a major expressway (SR-408) in Central Florida. A massive data collection effort was made to acquire driving behavior at the toll plaza using a driving simulator. Conclusions of the factors that affect risky driving behavior and recommendations were reached for improving toll plazas' safety.

### 1.4 Thesis Organization

This thesis is divided into seven chapters. The flow chart of thesis organization is shown in Figure 10. Chapter 1 presents the introduction of the research including the background of toll plazas, the main objectives of this research, and the organization of the thesis. Chapter 2 contains a literature review covering the driving behavior analysis at toll plazas and the effect of the signage and pavement markings on the risky driving behavior. Moreover, it presents the previous studies related to safety analysis using the driving simulator. Following by Chapter 3, which discusses the statistical approach for the validation procedure of the driving simulator data in order to use the driving simulator data for predicting the driving behavior of the toll plaza with the same conditions and road geometry, and for the validation of using the driving simulator for further studies related to toll plaza or for traffic safety. Chapter 4 covers the data preparation process using the driving

simulator. Chapter 5 contains the experimental design of the driving simulator experiments. Chapter 6 presents the statistical methodology that used for predicting the driving behavior results at toll plaza from the driving simulator data. A series of mixed linear regression models were used for achieving this goal. Chapter 7 contains the modeling results and discussion for each driving behavior variable. Chapter 8 focuses on the conclusions of the statistical model results. Also, it contains the research possible future recommendations that can be useful for further studies.

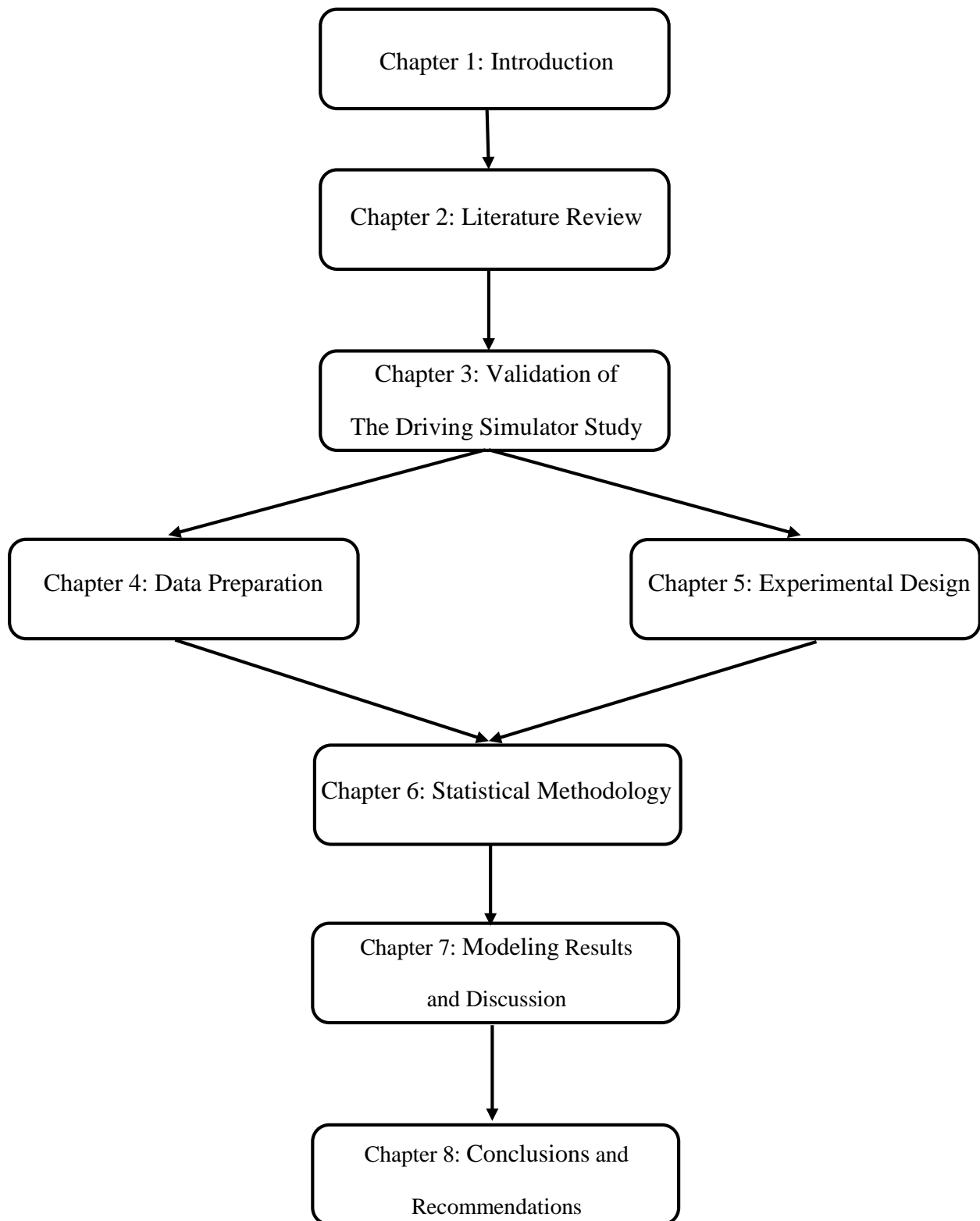

Figure 10. Flow Chart of Thesis sequence

## **CHAPTER 2. LITERATURE REVIEW**

### 2.1 Traffic Simulation

As indicated by Haleem (2007), traffic simulation plays a vital role in better understanding the traffic of the real world and producing accurately quick results. Using traffic simulation has many advantages. First, predicting the driving behavior due to a specific action. Second, exploring the reason why some events happened in the real world. Third, studying hotspot areas or regions with problems before carrying out solutions. Fourth, identify the impact of any modifications on the traffic system. Fifth, being familiar with all variables. Sixth, discovering the drawbacks of the traffic system. Seventh, efficiently simulate new ideas. Many studies used driving simulator experiments for carrying out conclusions for traffic safety studies. Lately, driving simulator has been a flexible and efficient tool for improving traffic safety analysis. It is also proven that using driving simulators in traffic safety studies is a cost-effective way for testing different scenarios which accurately replicated to the real world in a simulated environment. Consequently, driving simulators have to be validated with real world data as an important attempt to study traffic safety and especially for exploring driving behavior accurately (Abdel-Aty et al., 2006).

According to Nilsson (1993), driving simulator is one of the most efficient ways for investigating driving behavior and traffic safety impacts. That is because of many reasons. First, using a driving simulator is more efficient, and easier way for traffic data collection. Likewise, simulation is an alternative tool for evaluating different operations and improvements as field data collection is a costly and time-consuming process (Al-Deek and Mohamed, 2000). Second, driving simulator experiments can be used for exploring driving behavior with a similar environment to real life experience (Allen et al., 2011). Third, this method allows testing multiple scenarios

applicable to traffic control devices (e.g., signs, dynamic message signs (DMS), signals) (Bham et al., 2010). In conclusion, because of the enormous amount of field data required for studying the driver behavior, the simulation techniques are the most appropriate tool for conducting this kind of study.

## 2.2 Toll Plaza Safety

In the past decade, toll plaza systems have been increased in many countries especially in the United States. Despite, the benefits of constructing toll plaza in the expressways, there are limited studies evaluating the safety at toll plazas. The current studies indicated that, along toll plazas, there is certain location are more dangerous and more involved in traffic crashes than other locations (Abuzwidah, 2014).

One of the critical problems in the toll plaza areas is the drivers' confusion due to the various lane configurations and the different tolling systems. As indicated by McKinnon (2013), there are five types of tolling systems as shown in Table 1. First, the cash tolling system which is the traditional way of collecting tolls. The second system is the manual cash machine or the automatic coin machine (ACM) which speed up the movement of the vehicles than the first type. In the previous two systems, drivers decelerate before the toll plaza and then stop at the tollbooth for paying the tolls and then accelerate again to the mainline. Thus, this system is not only risky but time-consuming as well. Third, the combination of the manual and the electronic toll collection system which is the mixed of cash lanes and electronic toll collection (ETC) system in tollbooths. This system can be represented by the traditional mainline toll plaza. Electronic toll collection tag (ETC-tag) is used in the express lanes for collecting tolls automatically via transponders that installed in the vehicles. Fourth, the all-electronic toll collection system. Fifth, the express lanes

where tolls can be paid without reducing the speed or exiting the highway like open road tolling design (ORT) as shown in Figure 11 or high-occupancy (HOT) toll lanes as indicated in Figure 12.

Table 1. Tolling systems (Source: McKinnon, 2013)

Operational Toll Attributes			
Tolling Lane Types	Collection Method	Average Lane Speed (miles per hour)	Throughput (vehicles per hour)
Cash	Manual Attendant	Stop	300
Automatic	Manual Machine	Stop	500-600
Combination	Manual & Electronic	7	700
Dedicated	Electronic	15	1200-1500
Express	Electronic	55	1800-2200

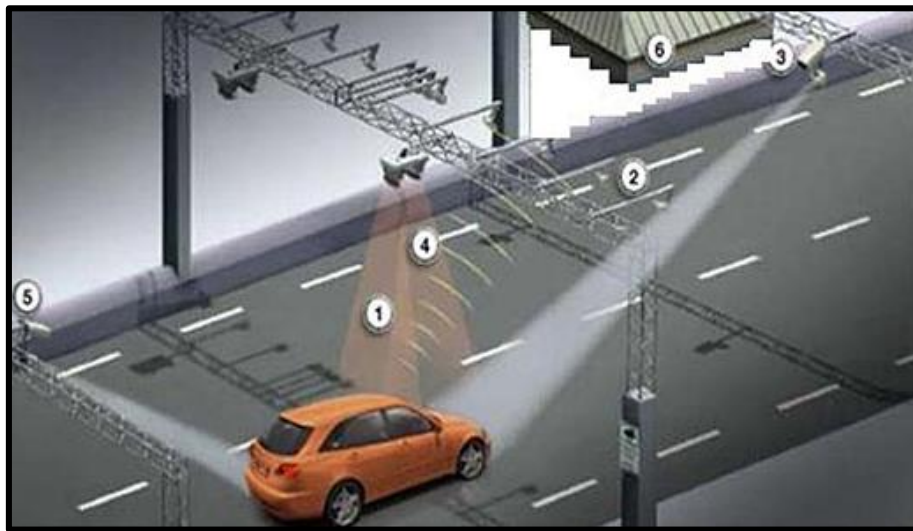

Figure 11. Electronic Tolling using ITS technique (Source: USDOT)

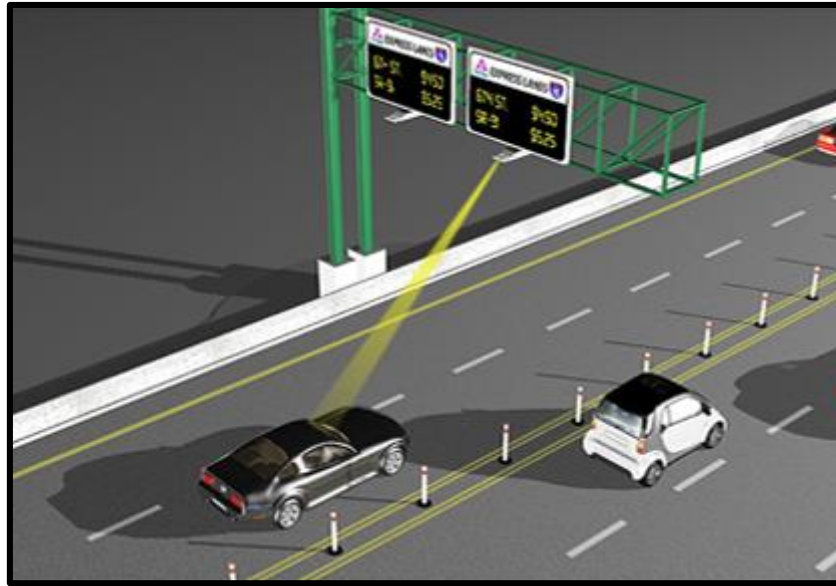

Figure 12. ETC at HOT lanes (Source: The Transit Coalition)

Moreover, McKinnon (2013) studied drivers' behavior at toll plazas by applying various scenarios for ETC system, cash system, and the combination system of both ETC and cash in the toll booths, as shown in Figure 13. The comparison between the scenarios was conducted by using the microsimulation technique. The results indicated that the best scenario was the one that has lane configuration of the combination case at all tollbooths because drivers are more likely to go through any lane configuration without changing lanes for different payment method. The second safer scenario was the one that has separated ETC lanes from cash lanes (Case 8). At that case, drivers experience less lane changing and less confusion compared to other mixed scenarios.

Case	Lane Configuration	Volume (Vehicles per hour)				Total	% Change
		Lane 4	Lane 3	Lane 2	Lane 1		
2013 Observed Configuration	Cash-EZPass-EZPass-Cash	270	390	503	277	1440	
Case 4	EZPass-Cash-Cash-EZPass	284	148	240	388	1060	-20%
Case 6	EZPass-Combo-Combo-EZPass	156	220	324	240	940	-29%
Case 8	EZPass-EZPass-Cash-Cash	576	304	200	232	1312	-1%
Case 13	EZPass-Combo-EZPass-Combo	188	228	160	368	944	-29%
Case 14/15	Combo-EZPass-EZPass-Combo	368	108	164	408	1048	-21%
Combination lanes	Combo-Combo-Combo-Combo	364	208	336	484	1392	5%

Figure 13. Toll Plaza Scenarios (Source: McKinnon, 2013)

Also, Abuzwidah and Abdel-Aty (2015) compared the traffic crashes between the three toll plaza designs, and they concluded that traffic crashes reduced considerably when the traditional mainline toll plazas (TMTP) or the hybrid mainline toll plazas (HMTP) is morphed to the all-electronic toll collection system (AETC). The traditional mainline toll plaza is the most critical choice among toll plazas' types because vehicles have to reduce speed before the tollbooth and navigate through cash lanes or express lanes for paying tolls. Also, the hybrid mainline toll plaza (HMTP) is risky design because of the speed variation between the tollbooth and the ORT. Consequently, TMTP and HMTP have an impact on increasing the unexpected lane change and the drivers' confusion near the toll plaza.

As indicated by Mohamed et al. (2001), after studying traffic crashes at 10 toll plazas on Central Florida's expressways for three and half years, about 46%, 32%, and 22% of traffic crashes were happened at the ramps before or after the toll plaza, at the toll plaza, and between the ramps and the toll plaza, respectively. Traffic crashes are mainly caused by the unexpected risky driving



behavior of drivers such as speed variation and sudden lane changes. There are two main reasons for drivers' confusion and risky driving behavior. First, some drivers are unfamiliar with the ETC system, so they reduce speed to understand the tolling system. Second reason for the drivers' confusion is the speed variation between the cash lanes and the ETC lanes. Figure 14 shows the possible conflict points before the traditional mainline toll plazas and the locations of the potential rear-end crashes and the sideswipe crashes. Furthermore, they investigated the effect of pavement markings' existence and the impact of using ETC-tag on toll plaza safety, and it was found that the two factors have a significant effect on reducing risky driving behavior.

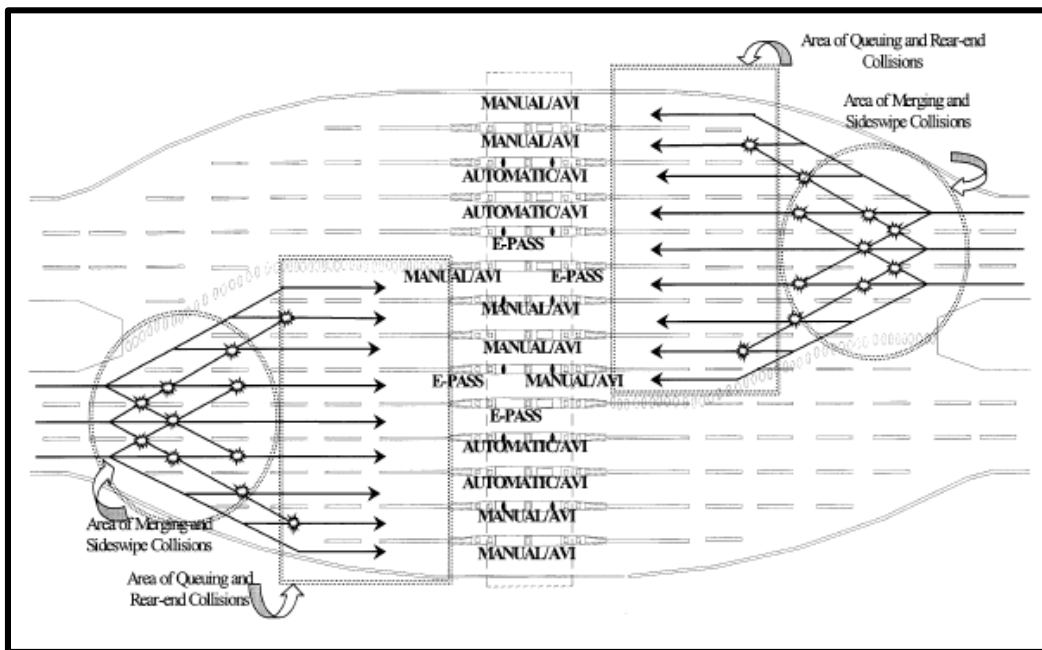

Figure 14. Possible Conflict Points at a TMTTP (Source: Abdelwahab and Abdel-Aty, 2002)

According to Abdelwahab and Abdel-Aty (2002), however, after the improvement of the ETC system and the evolution of the toll plazas' types, many researchers focused on studying toll plazas' efficiency and performance, but limited studies were conducted on the safety of the toll

plaza. Also, few researchers investigated the impact of signage, pavement markings, and other factors that influence the risky driving behavior near toll plazas. Therefore, it was recommended that drivers' dangerous behavior need to be explored for evaluating and improving toll plazas' safety.

Recently, Valdes et al., 2016, studied the risky factors that influence toll plazas' safety through a driving simulator experiment. They focused on exploring the impact of the overhead signage on the driving behavior before and after the toll plaza. They found that by using the overhead signage, the acceleration noise reduces by 8.33 % before the toll plazas and 16.66 % after the toll plazas. Additionally, the existence of the overhead signage reduces the standard deviation of road position by 41.66% before the toll plazas, 50% after the toll plazas and 50% at the toll plazas. Thus, overhead signage has an influence on improving toll plazas' safety and operation. Correspondingly, Carroll (2016) found that when installing overhead signs after on-ramp and before toll plaza, drivers are more likely to change lanes non-urgently. Additionally, extending the length between the toll plaza and the ramps had an impact on reducing unexpected lane change maneuvers.

Compared to previous studies, this study is unique because of using a variety of risk driving behavior indicators in addition to accounting for the data from the same participant in the driving simulator experiment by using random effect models. Moreover, a common deficiency of many of the above studies is ignoring the effect of the drivers' characteristics on risky driving behavior and ignoring the familiarity of the experiment since each participant drove in multiple scenarios.

## **CHAPTER 3. VALIDATION OF THE DRIVING SIMULATOR STUDY**

### 3.1 Background

Many researchers used driving simulator experiments for carrying out conclusions about traffic safety studies. Lately, driving simulators have been a successful facility for evaluating and improving traffic safety analysis. It is also proven that using driving simulators in traffic safety studies is an efficient and cost-effective tool which accurately replicate the real world for testing different options. Consequently, driving simulators have to be validated to check the similarity between the field data and the simulated data to ensure that the simulator experiment is acceptable as a considerable approach for studying driving behavior along with the other safety studies (Abdel-Aty et al.,2006).

The majority of previous studies used speed as a primary factor to validate the driving simulator data at different locations in the study area. It was found by Godley et al. (2002) that speed is proven to be a valid measure showing no significant difference between the mean speed obtained from the simulator experiment's data and the field data. Similarly, other researchers (Bham et al., 2014) compared the average speed of the simulator data and the field data which collected by GPS for four critical locations and results indicated that there is no considerable difference between the mean speed at the simulator data and the real world data for all the four locations. Bella et al., (2005) compared the field speeds and the driving simulator speeds for work zones and found that there is no difference between both data for ten measurement sites using z value. Bella et al., (2008) also compared field and simulator speeds for a two-lane rural road, and he found that there is no difference between both data for nine measurement sites. From the previous studies, it can be concluded that comparing the average speed at certain locations along

the study area between the field data and the driving simulation data is an appropriate approach for the driving simulator validation process.

In this study, speed data from the Microwave Vehicle Detection System (MVDS) was used to validate the driving simulator data. MVDS detectors are installed along the Central Florida expressways with less than one-mile spacing (Shi and Abdel-Aty, 2015). Figure 15 shows the MVDS detectors' locations with mileposts along the study area at the westbound of the state road (SR-408) as following: 19.9, 19.7, 19.4, 19, and 18.8 after the on-ramp, between the on-ramp and the toll plaza, before the toll plaza, after the toll plaza, and before the off-ramp, respectively. Moreover, only speed at each location can be used for validation process in this study because MVDS data provides speeds at specific location not by tracking vehicles along the segment. Therefore, speed variation, acceleration, and deceleration can not be used for validation process in this study.



Figure 15. Location of the Five Detectors Used for Validation (Source: Google Earth)

### 3.2 Statistical Approach for Driving Simulator Validation

A statistical t-test was conducted to compare the average speeds from the driving simulator data and the field data at five locations which was shown previously in Figure 15. The results revealed that there are no significant differences between the average speeds at the simulator

experiment's data and the field data for all studied locations along the study area, as shown in Table 2 and Figure 16. Thus, it can be inferred that the driving simulator data is validated, and it can be used for conducting further studies.

Table 2. Comparing Field Data and Driving Simulator Data for each Location

Location	description	Mile-post	t-value	p-value	Speed at driving simulator	Speed at field data	Difference of Speed
1	After the on-ramp	19.9	0.96	0.3395	56.2	55.2	1.0
2	Between the on-ramp and the toll plaza	19.7	-1.74	0.0843	62.2	63.6	-1.4
3	Before toll plaza	19.4	-0.59	0.5563	61.9	62.5	-0.6
4	After toll plaza	19	1.81	0.0725	60.7	58.9	1.8
5	Before second off-ramp	18.8	1.18	0.2424	61.7	60.3	1.4

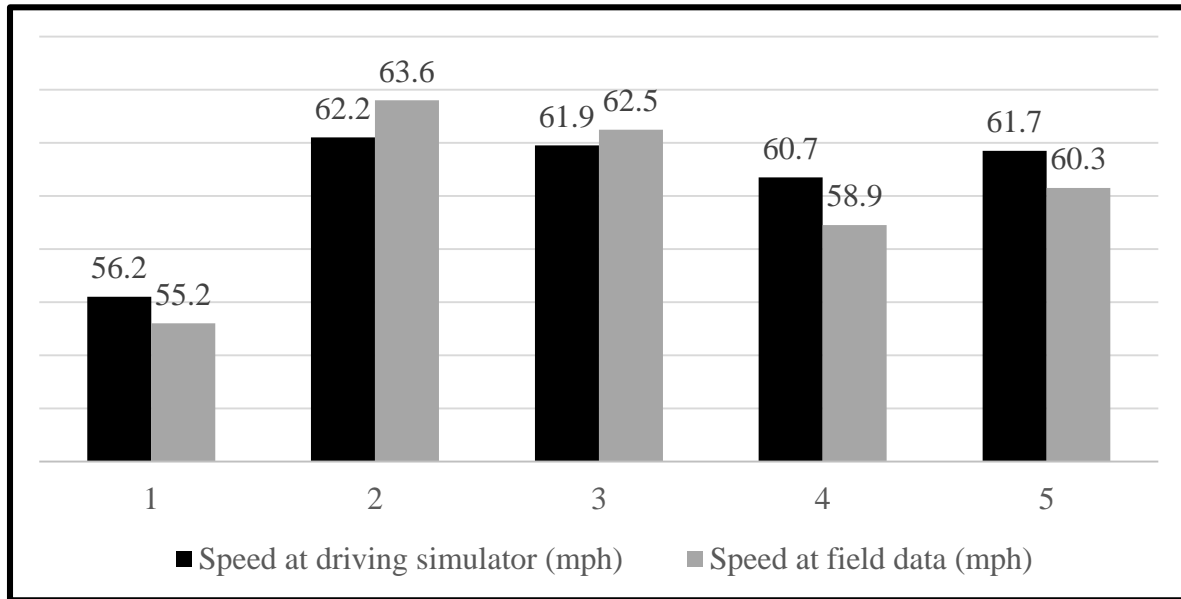

Figure 16. Average Speed Comparison between the Field and the Simulation Experiment at each location.

## **CHAPTER 4. DATA PREPARATION**

### 4.1 Data Collection

Due to the current needs to explore driving behavior and safety at toll plazas, the objective of this research is to apply various scenarios for studying lane change behavior, path decision-making, and also the influence of various signage, pavement markings, traffic conditions, and extending segment length and study the effect of these factors on toll plazas' safety. The data of this research was collected via driving simulator experiments. Drivers' characteristics were gathered from a questionnaire, as shown in Appendix A, before each experiment to study how driving behavior changes between different groups of drivers. These variables include age, gender, annual income, education level, crash experience, familiarity with the ETC-tag, professional driver, novice international driver, and driving frequency. Seven risky indicators including average speed, the standard deviation of speed, the standard deviation of lane deviation, the standard deviation of acceleration (acceleration noise), acceleration rate, deceleration rate, and the standard deviation of deceleration (braking action variation) were collected from the simulator experiments. Furthermore, since the simulator experiments were tested with human participants, the experiment was approved by the Institutional Review Board #1 (IRB no SBE-15-11026) at the University of Central Florida (UCF).

## 4.2 Study Area

This study focuses on studying the driving behavior at one toll plaza, the Dean Mainline Toll Plaza which is shown in Figure 17. It is located on state road (SR-408) in Orlando-Orange County, Florida as shown in Figure 18. Also, Figure 19 shows the state roads network in Florida and the location of the study area. This hybrid toll plaza is a combination of the open road tolling system (ORT) and the traditional system. The ORT part consisted of two express lanes and the traditional part consisted of four lanes, two of them are dedicated to the express lanes and the other two lanes are devoted to the cash lanes, as shown in Figure 20.



Figure 17. The Dean Mainline Toll Plaza (Source: Google Earth)

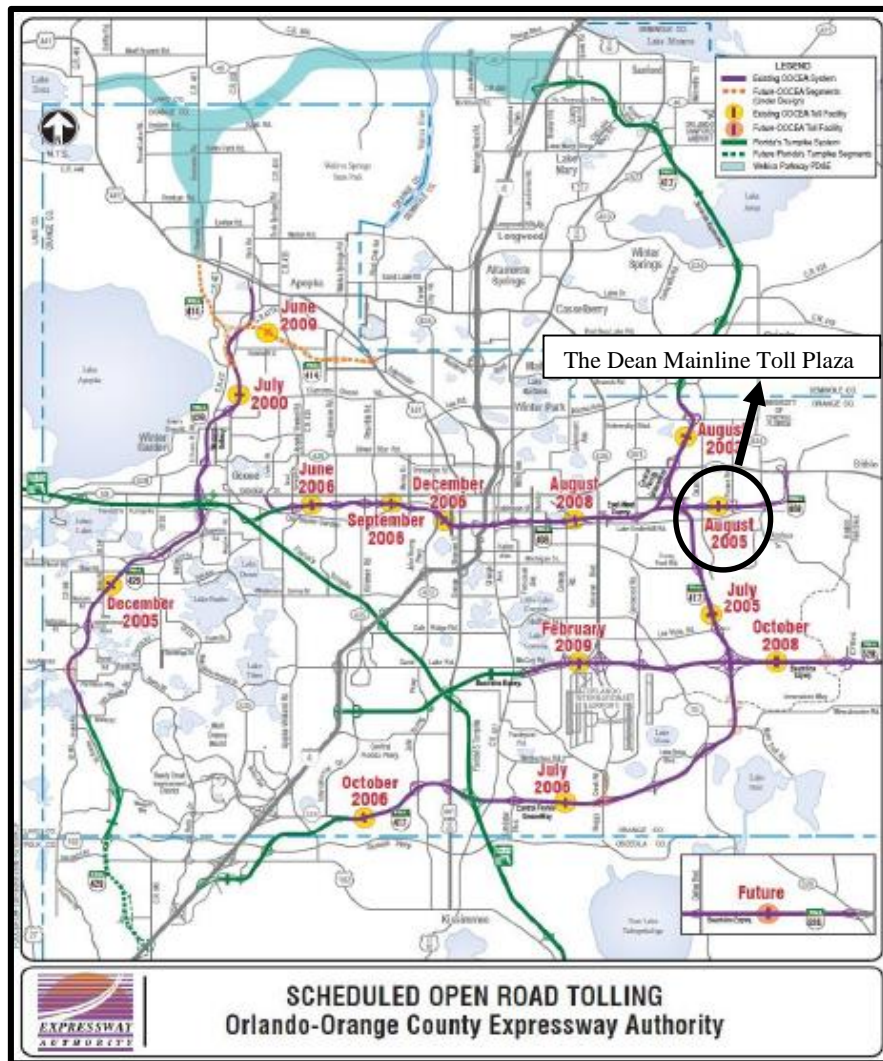

Figure 18. Toll Plazas at Orlando-Orange County Expressways (Source: CFX, and Abuzwidah, 2011)





Figure 19. Florida State Road Network (Source: FDOT, and Abuzwidah, 2011)

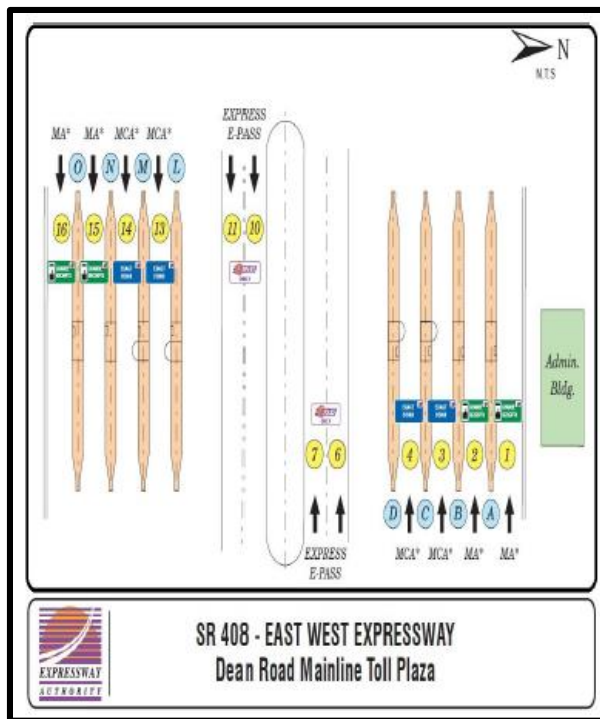

Figure 20. Dean Road Mainline Toll Plaza Design (Source: CFX, and Abuzwidah, 2011)

Four zones of interest, as shown in Figure 21, were analyzed at the toll plaza to investigate the risky driving behavior in different areas. The length of zone 1 is 0.25 miles which located between location 1 (after the on-ramp) and location 2 (between the on-ramp and the toll plaza). Zone 2 extends 0.25 miles between location 2 and location 3 (before the toll plaza). Zone 3 is the toll plaza zone with a length of 0.5 miles located between location 3 and location 4 (after the toll plaza). Finally, Zone 4 is the area that located after the toll plaza, and it extends 0.15 miles between location 4 and 5 (before the off-ramp).



Figure 21. Location of the Four Zones at SR-408 (Source: Google Earth)

### 4.3 The Driving Simulator

Research studies and data collection were completed at the University of Central Florida using NADS MiniSim™ Driving Simulator system, as shown in Figure 22 and Figure 23, which created by the University of Iowa. Three different tools are part of this system, The MiniSim™ driving simulator, The Tile Mosaic Tool (TMT), and The Interactive Scenario Authoring Tools (ISAT). The Tile Mosaic Tool (TMT) is used for building the real world road in a virtual model of the toll plaza design via the driving simulation. The NADS research center designed the TILES of the simulation in order to accurately replicate the real world environment of the Dean Mainline

Toll Plaza. Second, the Interactive Scenario Authoring Tools (ISAT) which was used to add vehicles, signs, and other traffic components to the scenarios. The traffic data inputs (i.e. volume, speed, and headways) for both peak and off-peak traffic conditions were based on the real world data which was collected from detectors located at SR-408 as shown previously in Figure 15.



Figure 22. UCF Driving Simulator



Figure 23. Driving Simulator Experiment at UCF

#### 4.4 Using MATLAB software for Extracting Data from the Driving Simulator

Data was extracted from the driving simulator to explore the driver risk behavior at toll plazas. MATLAB software was used to read the data from the driving simulator which was stored in a DAQ file format. Data was extracted for each frame of the simulator experiments and organized in an Excel file to be ready for the statistical process to achieve the goal of this study. By using DaqViewer option in MATLAB software, variables of the driving simulator experiments can be shown as in Figure 24. Variables that represent the driving behavior were picked from the DaqSelector as shown in Figure 25 to be extracted from the simulator experiments for each frame to be ready for the statistical process for each zone. Also, visualization of the variables can be represented by MATLAB software. Figure 26 shows the speed profile for a sample experiment, and Figure 27 shows the lane deviation profile by the fluctuating line.

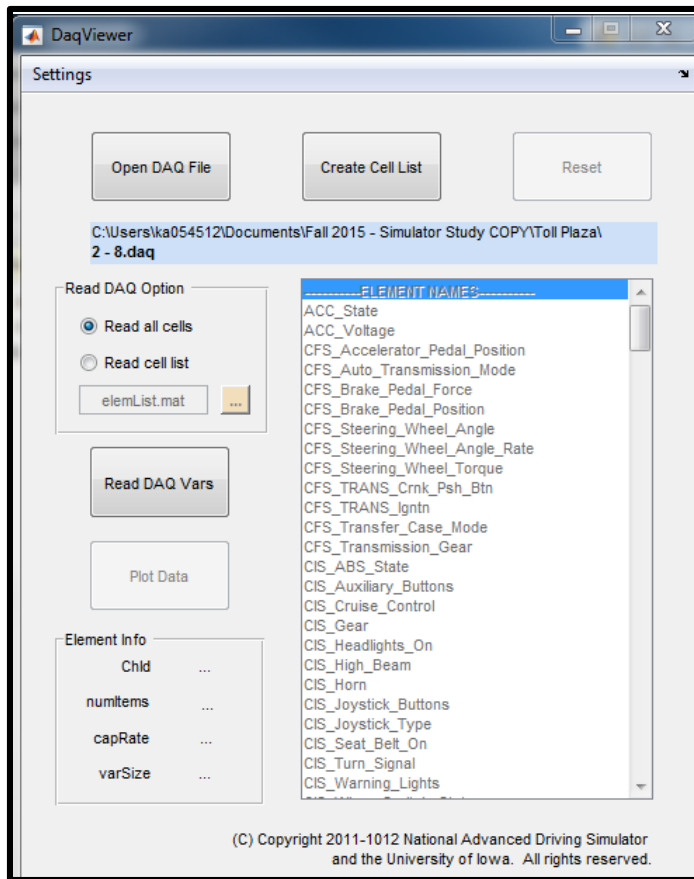

Figure 24. DaqViewer interface for extracting simulator data

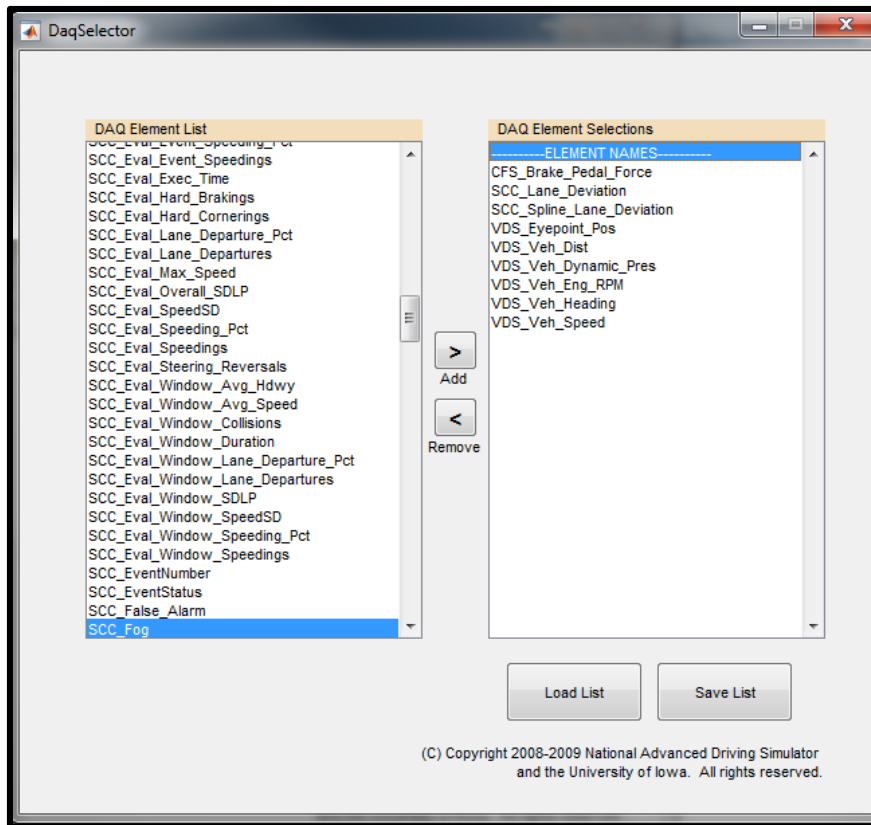

Figure 25. DaqSelector interface at MATLAB software

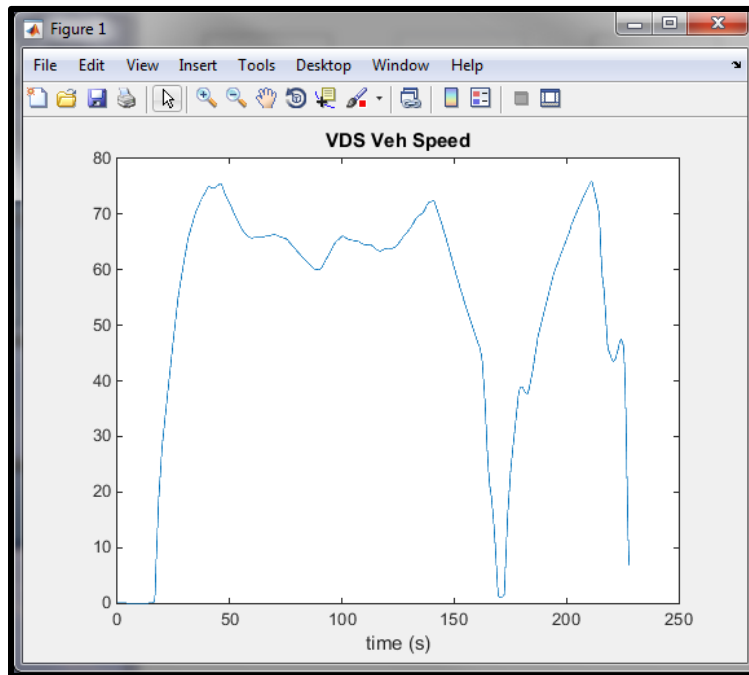

Figure 26. Example of a Speed Profile for an Experiment

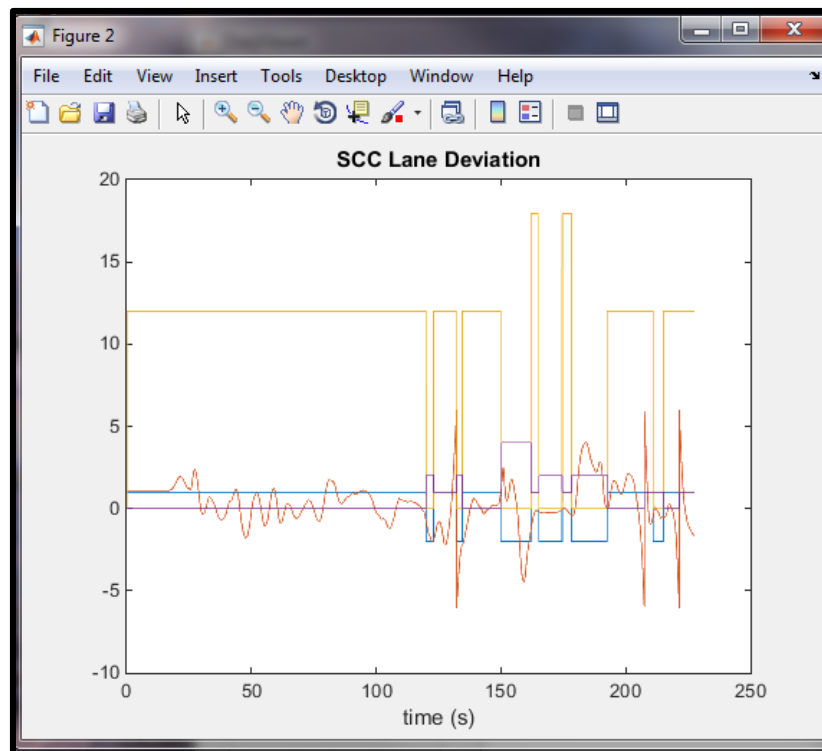

Figure 27. Example of Lane Deviation for an Experiment

#### 4.5 Driving Simulator Experiment Videos

Four cameras with 60 HZ frequency were installed to record the experiments. Three cameras were pointed at the participants' face, feet, and hands to observe participants' reaction. The last camera was pointed to the monitor to record the experiment. The experiment's videos show the four cameras' views and some experiment information (e.g., speed, frame number, and time) for each frame as shown in Figure 28. The videos were used for identifying the exact location of each zone, which was described before in Figure 15, by determining the exact frame of each location. Consequently, driving behavior can be investigated accurately for each zone for each participant.



Figure 28. Example of the Four Views of the Experiment videos



## **CHAPTER 5. EXPERIMENTAL DESIGN**

### 5.1 Driving simulator experimental design

Research studies and data collection were completed at the University of Central Florida using NADS MiniSim™ Driving Simulator system created by the University of Iowa. The driving simulation experiment was approved in 2015 by the Institutional Review Board (IRB) at UCF. The study is focused on one toll plaza, the Dean Mainline Toll Plaza as shown before in Figure 21, which located on one of the main expressways (SR-408) in Central Florida. The goal of this experimental design is applying different scenarios to explore the most significant factors that affect risky driving behavior at toll plazas considering drivers' characteristics. To achieve this goal, seventy-two drivers, 53% males and 47% females, were participated to complete the experiment. Drivers' individual characteristics were collected from a questionnaire before the experiment. From the flow chart that shows in Figure 29, first, participants have to be suitable for the driving simulator experiment. The criteria included that participants have to be older than 18 years old with a driver license. Also, drivers must be comfortable during the experiment and not suffering from motion sickness. Second, when the subject suffers from discomfort or simulation sickness, the subject was excluded from the experiment. After finishing all the experiments, the next step is the data collection step. In this experiment, no participant suffers from simulation sickness.

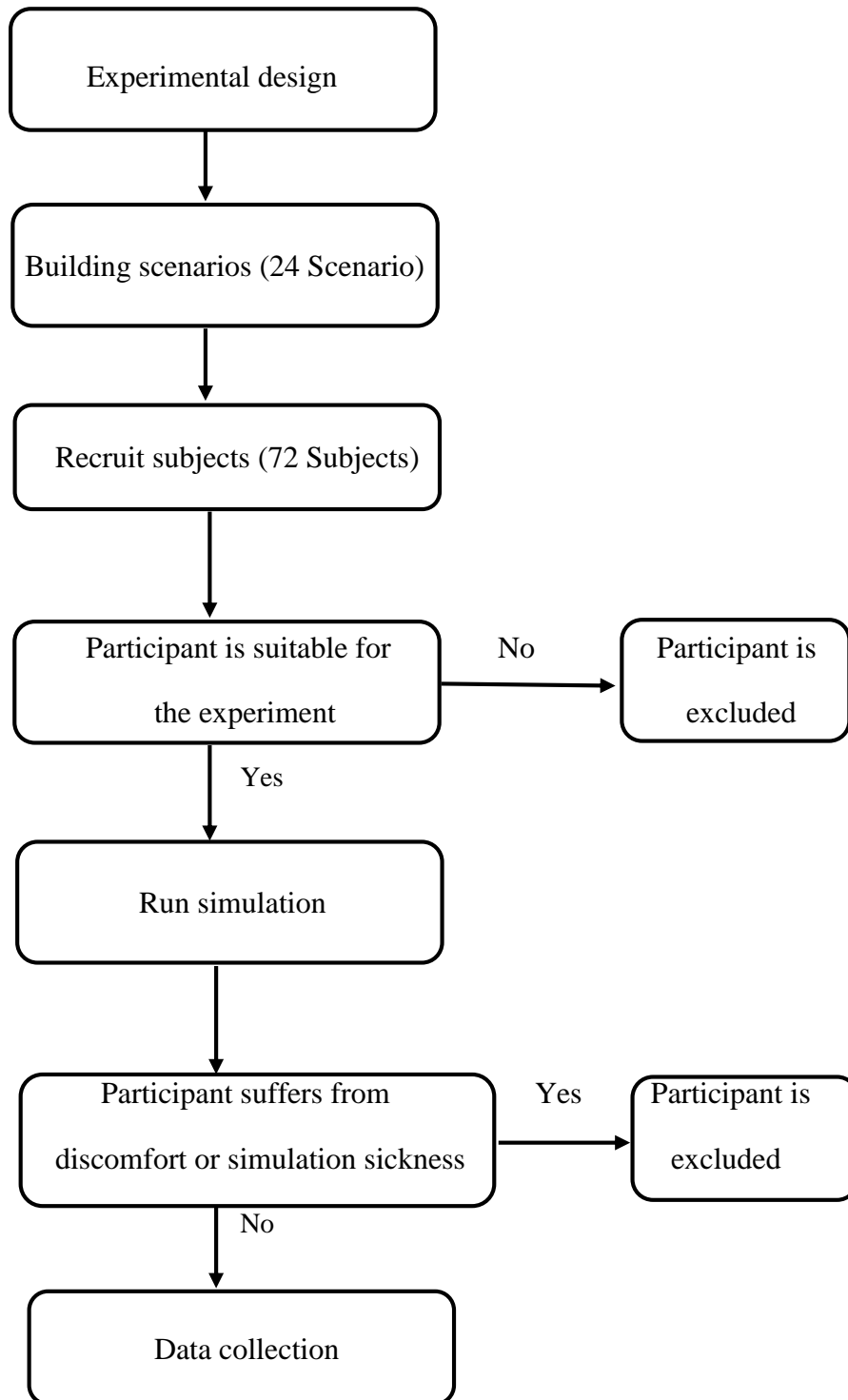

Figure 29. Experimental Design Flow Chart

## 5.2 Testing similarity between the driving simulation samples and the real world population

In order to prove the similarity between the driver simulator samples and the real world population, Florida Department of Transportation no-fault drivers' information was analyzed for two years (2013 and 2014) at SR-408 in Central Florida which extracted from Crash Analysis Reporting System (CARS) data. Table 3, Figure 30, and Figure 31 show the number and percent of participants grouped by gender and age for the simulator and the real-world information. Four groups of age were used to achieve this goal including the first group is from 18 to 25 years old, the second group is from 25 to 35 years old, the third category is from 35 to 50 years old, and the fourth group is the drivers who are older than 50 years old. The quasi-induced exposure method was used to achieve this goal. This method is used to represent the driving population from the distribution of the no-fault drivers in the crash database (Stamatiadis and Deacon, 1997; Chandraranta and Stamatiadis, 2009). Thus, real world data were collected for no-fault drivers by excluding data for dangerous drivers (e.g., alcohol users, drug users, and drivers with violation behavior who received traffic citations). Subsequently, the Chi-Square statistical test was performed between driving simulator experiment data and real world information ( $\chi^2=4.665$ , the degree of freedom=7,  $p=0.701$ ). The results indicated that there is no statistically significant difference at 5% significance level between the number of participants grouped by gender and age at the driving simulator experiment and the real world.

Table 3. Comparing Number of Drivers between Simulator Experiment and Real world

Gender	Age group	Real World		Driving Simulator		Total	
		Number	Percent	Number	Percent	Number	Percent
Male	18-25	21	15%	10	14%	31	14%
	25-35	16	11%	13	18%	29	14%
	35-50	29	20%	8	11%	37	17%
	>50	14	10%	7	10%	21	10%
Female	18-25	23	16%	13	18%	36	17%
	25-35	17	12%	11	15%	28	13%
	35-50	14	10%	6	8%	20	9%
	>50	8	6%	4	6%	12	6%
Total		142	100%	72	100%	214	100%

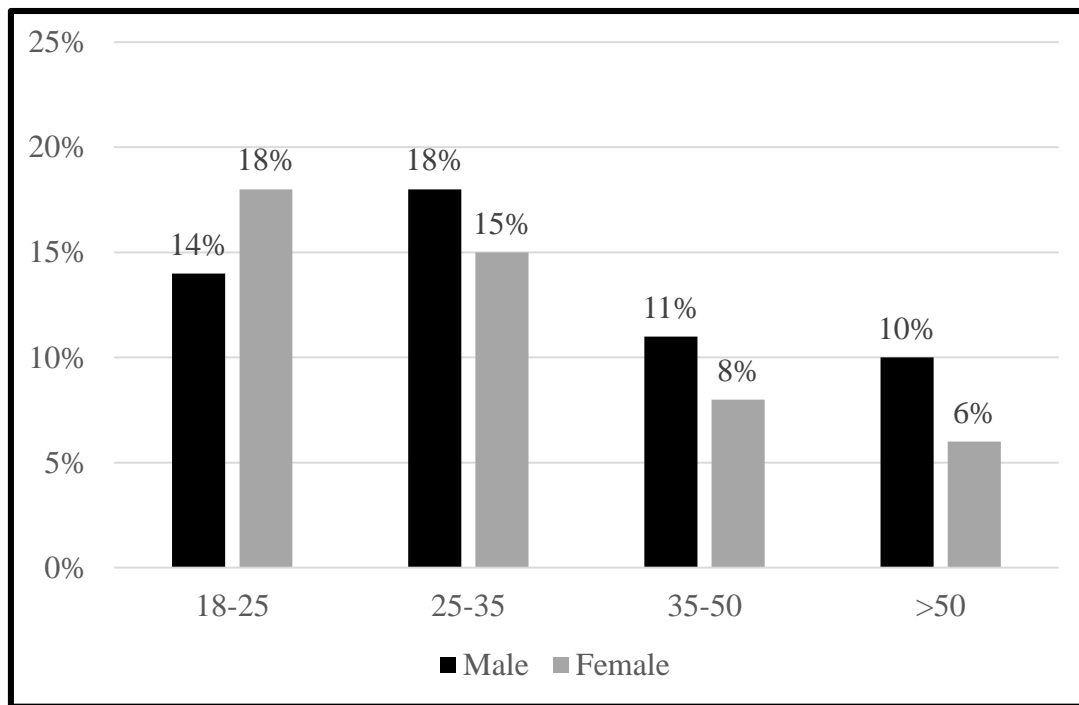

Figure 30. Percentages of Male and Female Participants in each Age Group from The Driving Simulator Data

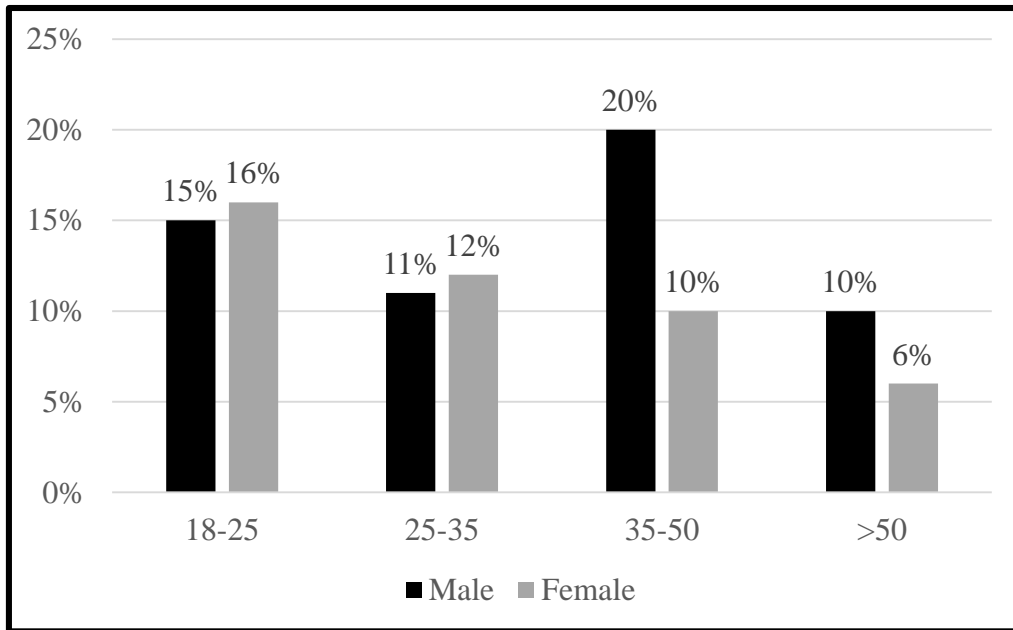

Figure 31. Percentages of Male and Female Participants in each Age Group from Real World data

### 5.3 Simulator sickness

After each experiment, participants were asked to have a break for several minutes and to fulfill a questionnaire to check for simulation sickness or discomfort. Simulator sickness and the way to overcome it are very concerning points from the early days of using driving simulators (Allen,2011; Reason, 1978; Frank et al.,1988). One reason of the simulator sickness is the fatigue that happened because of the long simulation time (Blana, 1996). That is why there are no simulator sickness cases in this study because each scenario did not exceed 5 minutes.

## 5.4 Scenario Variables

Twenty-four scenarios, as shown in Table 4, were studied through the driving simulator for five scenario variables including path, signage, pavement markings, traffic condition, and extending auxiliary lanes before and after the toll plaza. Each participant was asked to navigate in three different scenarios randomly selected from 24 options.

Table 4. Description of experiment Scenarios

<b>Scenario</b>	<b>Path</b>	<b>Traffic</b>	<b>Pavement Markings</b>	<b>Auxiliary Lanes</b>	<b>Signage</b>
1	1	Peak	Not Exist	Case 3	Case 3
2	1	Peak	Not Exist	Case 2	Case 3
3	1	Off-Peak	Exist	Case 3	Case 1
4	1	Off-Peak	Exist	Case 1	Case 1
5	2	Peak	Exist	Case 3	Case 1
6	2	Peak	Exist	Case 2	Case 3
7	2	Off-Peak	Not Exist	Case 2	Case 1
8	2	Off-Peak	Not Exist	Case 1	Case 3
9	3	Peak	Not Exist	Case 3	Case 1
10	3	Peak	Not Exist	Case 1	Case 1
11	3	Off-Peak	Exist	Case 2	Case 3
12	3	Off-Peak	Exist	Case 1	Case 3
13	4	Peak	Exist	Case 2	Case 2
14	4	Peak	Exist	Case 1	Case 2
15	4	Peak	Not Exist	Case 1	Case 1
16	4	Off-Peak	Exist	Case 3	Case 2
17	4	Off-Peak	Not Exist	Case 3	Case 3
18	4	Off-Peak	Not Exist	Case 2	Case 1
19	5	Peak	Exist	Case 3	Case 3
20	5	Peak	Exist	Case 1	Case 3
21	5	Peak	Not Exist	Case 2	Case 2
22	5	Off-Peak	Exist	Case 2	Case 1
23	5	Off-Peak	Not Exist	Case 3	Case 2
24	5	Off-Peak	Not Exist	Case 1	Case 2

### 5.4.1 Path

Five paths were investigated in the experiment as illustrated in Figure 32.

- Path 1: drivers come from the mainline through the open-tolling road.
- Path 2: drivers come from the mainline to the tollbooth and then merge back to the mainline.
- Path 3: drivers come from the mainline through the open tolling road and then heading to the off-ramp.
- Path 4: drivers come from the on-ramp to the mainline and go through the open-tolling road.
- Path 5: similar to the fourth path, drivers come from the on-ramp to the mainline using the tollbooth and then merge with the mainline traffic.

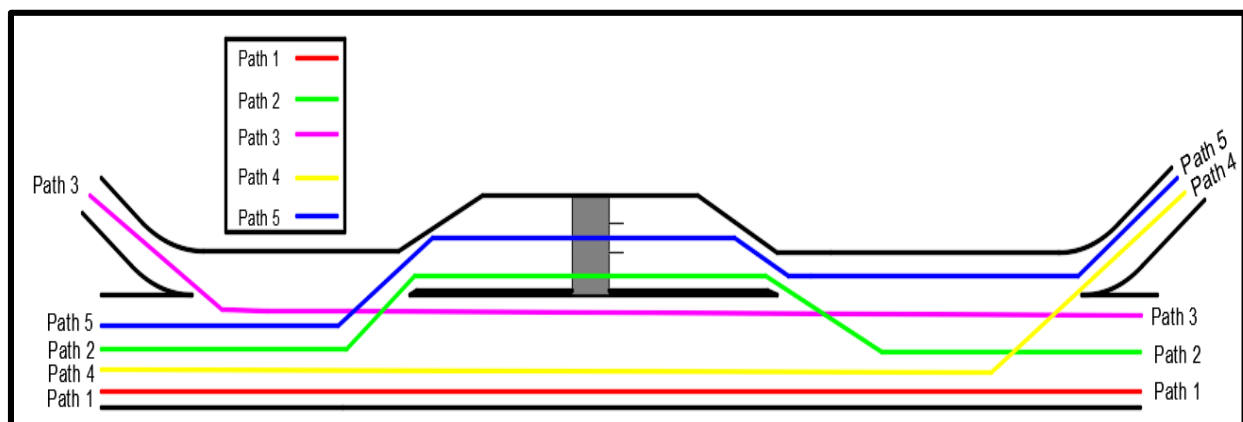

Figure 32. Path Cases

## 5.4.2 Signage

Signage has three cases as shown in Figure 33.

- Case 1: the default condition consists of the second overhead sign after the on-ramp and the third overhead sign before the toll plaza. The overhead sign in shown in Figure 34.
- Case 2: Adding a portable DMS at the on-ramp, as shown in Figure 35, with the message “ALL ON RAMP VEHICLES KEEP RIGHT,” in addition to removing the third overhead sign before the toll plaza and relocating the second overhead sign after the on-ramp to the first location before the on-ramp.
- Case 3: Removing the third overhead sign while keeping the second overhead sign.

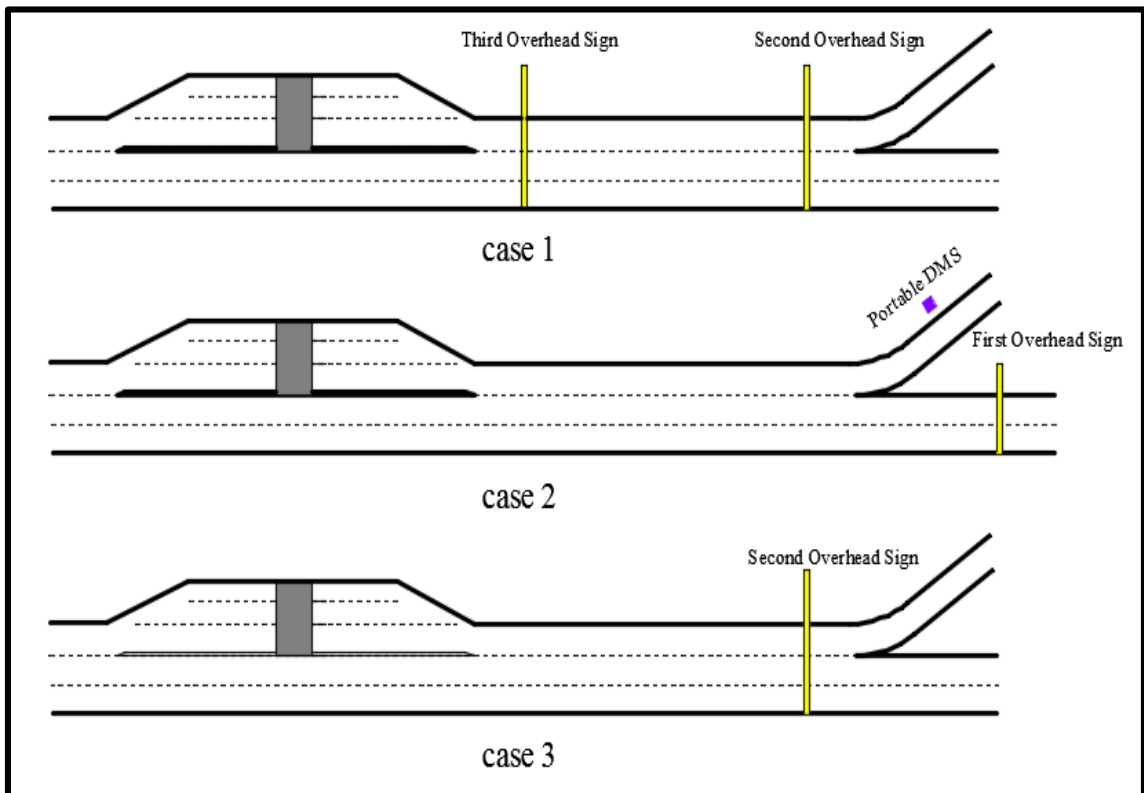

Figure 33. Signage Cases





Figure 34. Overhead Sign (Source: Google Earth)



Figure 35. Portable DMS in the Simulator

Locations, dimensions and colors of the signs and pavement markings in the simulator follow the Central Florida Expressway Authority standards for preparation of signing and pavement marking plans, 2014, and the Manual on Uniform Traffic Control Devices (MUTCD, 2009) requirements as shown in Figure 36.

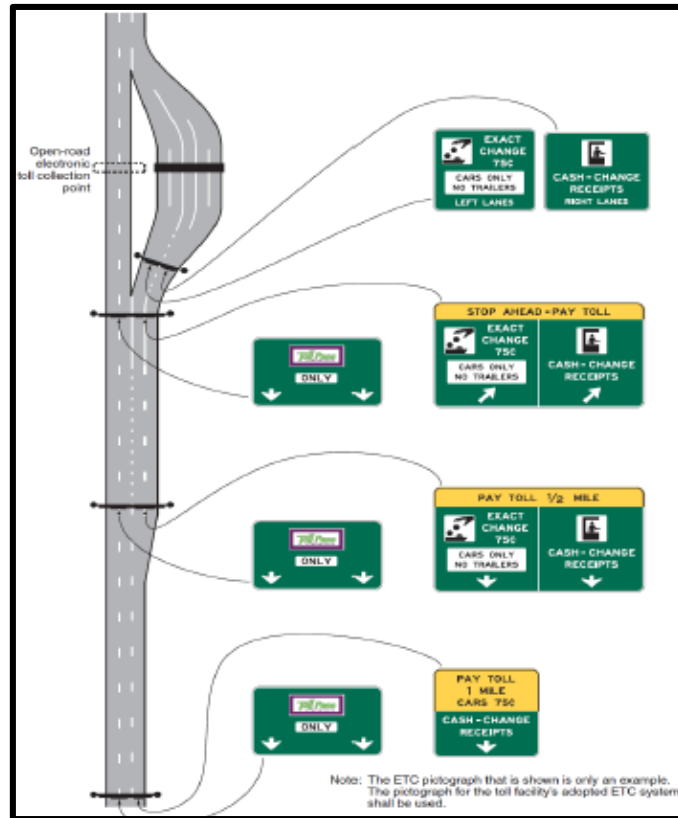

Figure 36. Example of Guide Signage Locations for the Hybrid Toll Plaza (Source: MUTCD 2009)

### 5.4.3 Extending Auxiliary Lanes

The third factor is extending auxiliary lanes, and it has three cases:

- Case1: Adding 660 feet after the toll plaza.
- Case2: Adding 660 feet before the toll plaza.

- Case3: the base length of the auxiliary lanes before and after the toll plaza.

#### 5.4.4 Pavement Markings

The fourth variable is adding arrow pavement markings before and after the toll plaza as shown in Figure 37 and Figure 38, and test the effect of removing the arrow pavement markings on the driving behavior.



Figure 37. Arrow Pavement Markings (Source: Google Earth)

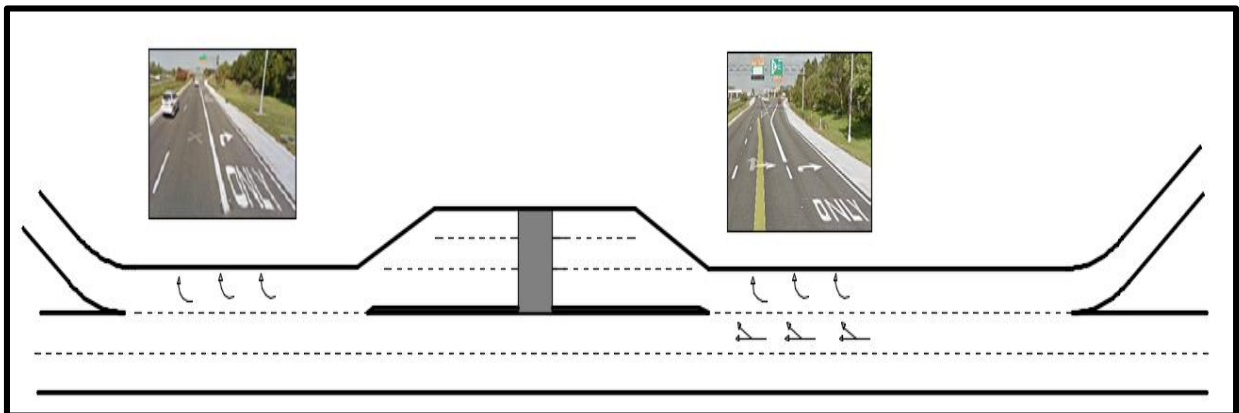

Figure 38. Pavement Markings Case

#### 5.4.5 Traffic Conditions

The fifth factor is the traffic condition. Some participants are asked to drive in congested conditions at peak hour, which was considered between 7:00 AM and 8:00 AM and others was asked to drive in uncongested condition at an off-peak hour, which was examined between 12:30 PM and 1:30 PM. The frequencies and percentages for each level of each scenario variable are shown in Table 5.

Table 5. Descriptive Statistics of Scenario Variables

Variable	Level	Description	Freq.	%	Cum. Freq.	Cum. %
Path	1	Mainline-Open Tolling- Mainline	13	18.06	13	18.06
	2	Mainline-Cash Tollbooth- Mainline	11	15.28	24	33.33
	3	Mainline-Open Tolling-Off Ramp	15	20.83	39	54.17
	4	On Ramp- Open Tolling - Mainline	15	20.83	54	75
	5	On Ramp- Cash Tollbooth - Mainline	18	25	72	100
Signage	1	Case 1 (base)	26	36.11	26	36.11
	2	Case 2 (install DMS and relocate the signs)	13	18.06	39	54.17
	3	Case 3 (remove third sign)	33	45.83	72	100
Extending auxiliary lanes	1	Add 660 feet after the toll plaza	26	36.11	26	36.11
	2	Add 660 feet before the toll plaza	13	18.06	39	54.17
	3	No change (base)	33	45.83	72	100
Traffic Condition	1	Off-peak	35	48.61	35	48.61
	2	Peak	37	51.39	72	100
Pavement Marking	1	Not Exist	34	47.22	34	47.22
	2	Exist	38	52.78	72	100

## 5.5 Driver Characteristics

Drivers' characteristics were collected from the questionnaires before each experiment. Driver characteristics variables are age, gender, annual income, education level, driving frequency, professional driver, crash experience, ETC-tag user, and novice international driver. Among variables, age was aggregated into five categories. The first group is from 18 to 25. The second group is from 25 to 35. The third group is from 35 to 50. Fourth category from 50 to 60. The last group is the drivers who are older than 60. Also, income was also grouped into two categories: less than \$40,000 annually and \$40,000 annually or higher. Correspondingly, education was divided into two categories, participants with a bachelor degree or lower, and the other category is the participants with a higher degree than a bachelor. Furthermore, driving frequency was gathered into three categories: drivers with driving frequency less than five trips per week, drivers with one or two trips per day, and drivers with higher than three trips per day. In order to study the novice international drivers' behavior, two variables interacted. These two variables are learn driving outside the US and Years of Florida's driving license. Learn driving outside the US variable was divided into two categories: learn driving in the US and learn driving outside the US. Years of Florida's driving license variable was split into five categories: less than five years, from 5 to 10 years, from 11 to 15 years, from 16 to 20 years, and more than 21 years. Novice international driver variable is the interaction between the learn driving outside the US variable and the years of Florida's driving license variable. Thus, novice international drivers are the international drivers who have a Florida license less than five years. Frequency and percent of each drivers' characteristics variable are shown in Table 6. It can be concluded from the table that professional driver variable will not be used in the study because most of the participants (94.44%) responded that they are not professional drivers. Similarly, most of the subjects (95.83%) are not novice

international drivers. Thus, this variable also will be excluded from the study. Visualization of the driving characteristic variables and cross-tabulations are attached in Appendix B.

Table 6. Descriptive Statistics for Driver Characteristics

<b>Variable</b>	<b>Level</b>	<b>Description</b>	<b>Freq.</b>	<b>%</b>	<b>Cum. Freq.</b>	<b>Cum. %</b>
<b>Age</b>	1	18 to 25	23	31.94	23	31.94
	2	25 to 35	24	33.33	47	65.28
	3	35 to 50	14	19.44	61	84.72
	4	50 to 60	6	8.33	67	93.06
	5	60 or more	5	6.94	72	100
<b>Gender</b>	1	Male	38	52.78	38	52.78
	2	Female	34	47.22	72	100
<b>Driving frequency</b>	1	1 to 5 trips per week	14	19.44	14	19.44
	2	1 or 2 trips per day	17	23.61	31	43.06
	3	More than 3 trips per day	41	56.94	72	100
<b>Annual Income</b>	1	Lower than \$40,000	36	50	36	50
	2	\$40,000 or higher	36	50	72	100
<b>ETC-tag use</b>	1	Yes	57	79.17	57	79.17
	2	No	15	20.83	72	100
<b>Professional driver</b>	1	Yes	4	5.56	4	5.56
	2	No	68	94.44	72	100
<b>Novice international drivers</b>	1	Yes	3	4.17	3	4.17
	2	No	69	95.83	72	100
<b>Education</b>	1	Bachelor's degree or lower	50	69.44	50	69.44
	2	Higher than bachelor's degree	22	30.56	72	100
<b>Crash experience</b>	1	Yes	13	18.06	13	18.06
	2	No	59	81.94	72	100

## 5.6 Driving Behavior

Drivers are required to make many decisions at expressway toll plazas due to the diverging and merging areas after and before the toll plaza which results in drivers' confusion and dangerous behavior such as speed variation and unexpected weaving maneuvers. Additionally, previous studies recommended the investigation of risk behavior at the toll plaza areas (Abdelwahab and Abdel-Aty, 2002; McKinnon, 2013). Consequently, data were analyzed for variables that represent risky driving behavior including average speed, the standard deviation of speed, the standard deviation of lane deviation, acceleration noise, acceleration rate, deceleration rate, and the standard deviation of deceleration. Speed change rate can be reflected by the acceleration and the deceleration. The descriptive statistics of the driving behavior variables are shown in Table 7. The descriptive statistics and the histograms for each level of each driving behavior variable are shown in Appendix B.

Table 7. Descriptive Statistics for Driving Behavior Variables

<b>Variable</b>	<b>N</b>	<b>Mean</b>	<b>SD</b>	<b>Minimum</b>	<b>Maximum</b>
<b>Average Speed (mph)</b>	832	57.936	11.152	18.686	88.996
<b>Standard deviation of speed (mph)</b>	832	5.982	5.640	0.178	28.863
<b>Log standard deviation of speed (mph)</b>	832	0.623	0.363	-0.750	1.461
<b>Standard deviation of lane deviation (ft)</b>	832	1.430	0.733	0.079	3.293
<b>Log Standard deviation of lane deviation (ft)</b>	832	0.078	0.286	-1.101	0.518
<b>Acceleration (m/sec<sup>2</sup>)</b>	822	1.346	1.434	0.022	6.694
<b>Log acceleration (m/sec<sup>2</sup>)</b>	822	0.135	0.175	-0.582	0.526
<b>Acceleration noise (m/sec<sup>2</sup>)</b>	822	0.322	0.356	0.005	1.889
<b>Log acceleration noise (m/sec<sup>2</sup>)</b>	822	-0.152	0.186	-0.869	0.280
<b>Deceleration (m/sec<sup>2</sup>)</b>	791	2.146	2.865	0.022	11.103
<b>Log deceleration (m/sec<sup>2</sup>)</b>	791	0.170	0.219	-0.577	0.626
<b>Standard deviation of deceleration (m/sec<sup>2</sup>)</b>	791	0.510	0.738	0.004	3.589
<b>Log standard deviation of deceleration (m/sec<sup>2</sup>)</b>	791	-0.116	0.215	-0.827	0.402



### 5.6.1 Average Speed

Data was collected from the driving simulator by using MATLAB software. Speed and lane deviation variables were directly extracted for each zone of the study area. The average speed for each zone is shown in Table 8. It can be inferred from Tables 7 and 8 that the average speed along the study area is 57.9 mph. The maximum of the average speeds is along the fourth zone after the toll plaza with 61.59 mph, and the minimum average speed is along zone three at the toll plaza zone with 52.1 because of the variation of speed between the cash lanes at the toll plaza booth and the express lanes at the ORT. The histogram of the average speed is shown in Figure 39.

Table 8. Descriptive statistics of Average Speed for each zone

Average Speed (mph)	zone	N	Mean	Standard Deviation	Minimum	Maximum
	1	208	57.61	7.22	26.75	76.81
	2	208	60.44	7.64	31.54	82.01
	3	208	52.10	15.89	18.69	87.81
	4	208	61.59	9.06	37.15	89.00

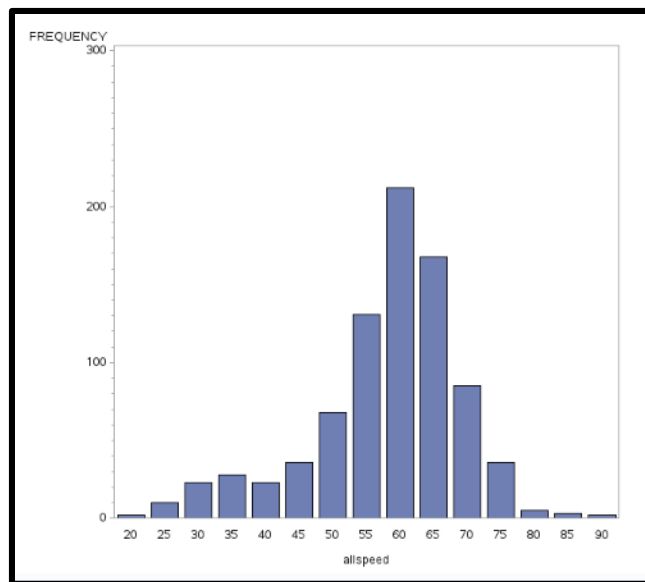

Figure 39. Average Speed Histogram

### 5.6.2 Lane deviation

Lane deviation in the driving simulator data is defined by values between -6 feet and 6 feet. When the vehicle drives in the centerline of the lane, the value of the lane deviation is zero. Lane deviation increases from 0 to 6 ft while the driver is heading right to the end of the lane, and it decreases from 0 to -6 ft while the vehicle moves to the left to the end of the lane as shown in Figure 40 which represent an example of the lane deviation for scenario number 8 which represent the second path from mainline to the tollbooth and then heading back to the mainline. The first drop in the figure represents one lane change of the vehicle to the right from mainline to the tollbooth. Similarly, the two drops at the end of the lane deviation profile illustrate two lane change to the left from the tollbooth to the mainline. Standard deviation of lane deviation was used as a driving risk behavior indicator as when the standard deviation of lane deviation is lower, the driving performance is better (Reed, and Green, 1999).

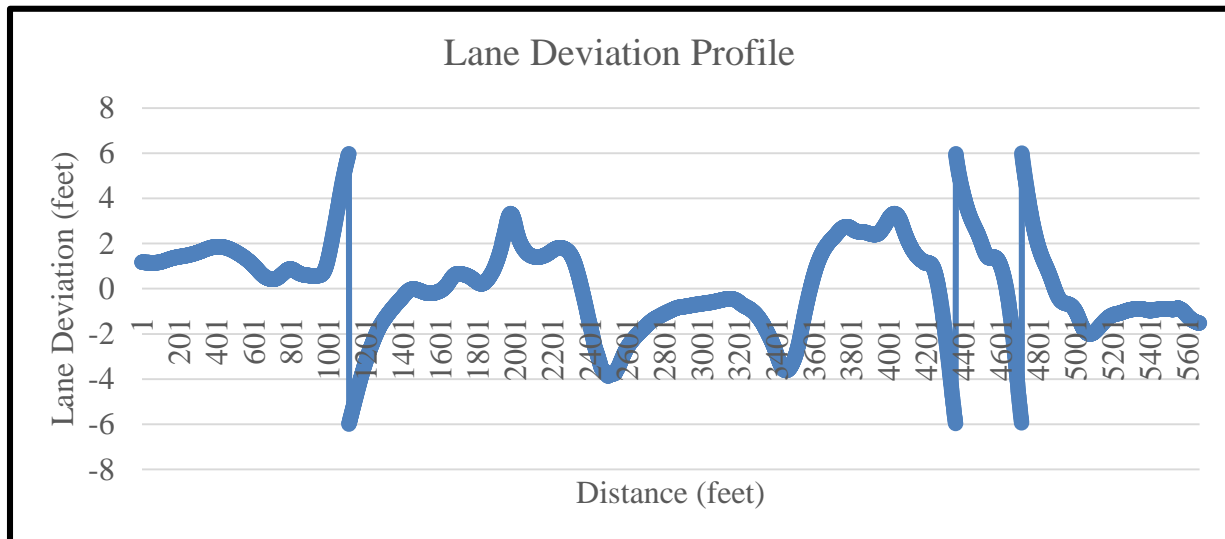

Figure 40. Lane Deviation Profile for Participant 52 Scenario 8

### 5.6.3 Acceleration noise

Acceleration noise study has seldom been investigated due to the difficulty of data collection. Nevertheless, some studies explored the acceleration noise and its relation to the driver behavior. Researchers denominated standard deviation of acceleration of a vehicle as acceleration noise to measure the quality of traffic flow and describe the speed fluctuations degree. Acceleration noise was proposed from half century ago to characterize traffic conditions. It was found that acceleration noise indicated that faster drivers probably did a certain amount of weaving and passing than slower drivers (Herman et al.,1959). Likewise, acceleration noise of faster drivers is greater than slower drivers when drivers exceed the design speed (Jones and Potts, 1962). Correspondingly, it was found that acceleration noise is significantly influenced by driver characteristics (Ko et al.,2010).

In this study, acceleration rate was calculated from the maximum value of the difference between speeds for each second. Also, Acceleration noise can be calculated accurately from the driving simulator data. Acceleration noise was calculated as the standard deviation of acceleration between speeds for each second. An example of the speed profile is shown in Figure 41 for scenario number 10 for participant number 1.

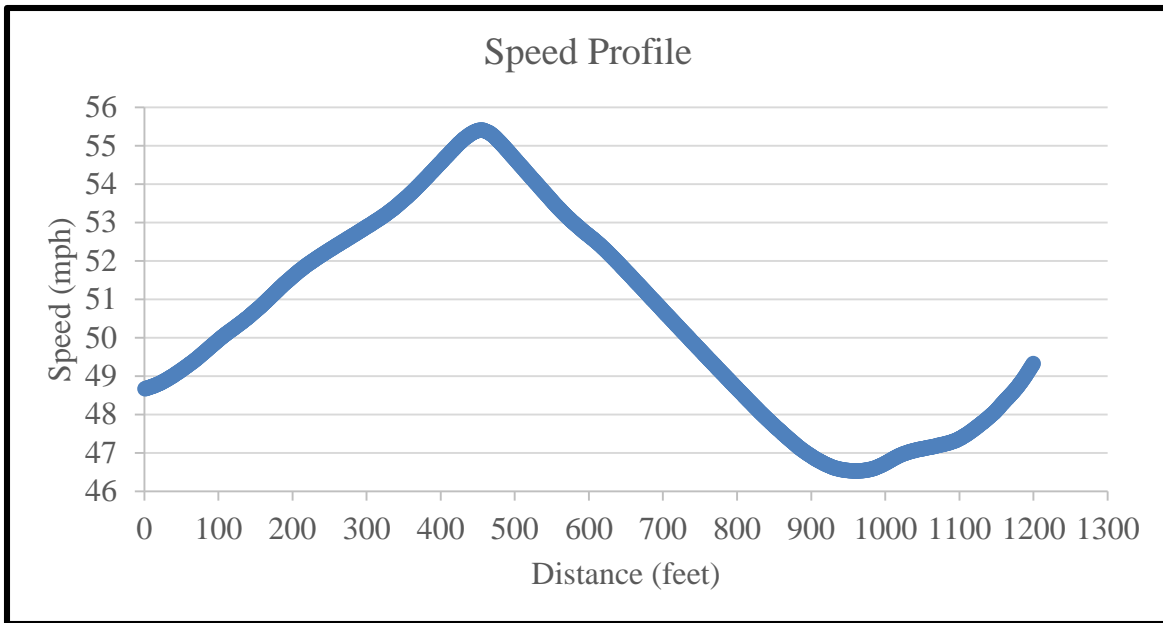

Figure 41. Speed Profile for Participant 1 Scenario 10

#### 5.6.4 Testing normality of the variables

The distributions of the standard deviation of speed, acceleration noise, acceleration rate, deceleration rate, and standard deviation of deceleration deviate from the normal distribution. Consequently, a series of transformations were applied using the SAS Enterprise Miner 13.1 software. Results revealed that log transformations accomplish the lowest skewness and kurtosis from the normal distribution for these variables. Next step explains the normality test for all the driving behavior variables.

##### 5.6.4.1 Testing Normality for Average Speed Variable

Table 9 and Figure 42 show the Kolmogorov-Smirnov results to test normality for average speed. It can be concluded that there is no significant difference between the distribution of the

average speed and normal distribution ( $D=0.039$ ,  $p>0.15$ ). Consequently, average speed variable does not need any transformation.

Table 9. Kolmogorov-Smirnov results for Average Speed

Goodness-of-Fit Tests for Normal Distribution				
Test	Statistic		P Value	
Kolmogorov-Smirnov	D	0.03912422	Pr > D	>0.150
Cramer-von Mises	W-Sq	0.05477103	Pr > W-Sq	>0.250
Anderson-Darling	A-Sq	0.34465227	Pr > A-Sq	>0.250

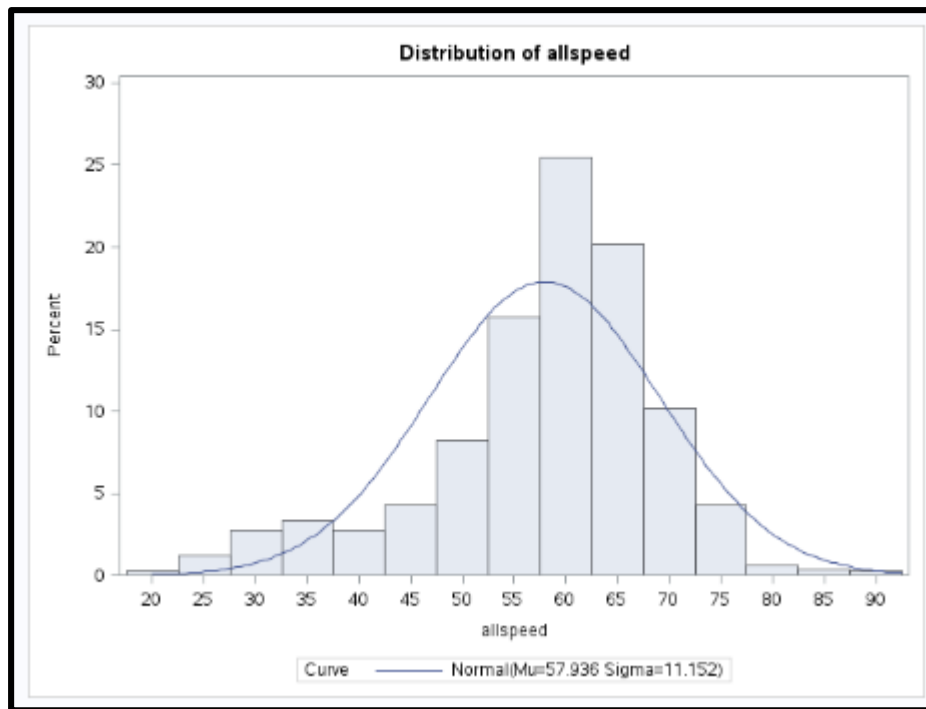

Figure 42. Average Speed Histogram

### 5.6.4.2 Testing Normality for Standard Deviation of Speed Variable

Table 10 and Figure 43 show the Kolmogorov-Smirnov results to test normality for the standard deviation of speed. It can be concluded that there is a significant difference between the distribution of the standard deviation of speed and normal distribution ( $D=0.207$ ,  $p<0.01$ ). Consequently, the standard deviation of speed variable needs transformation.

Table 10. Kolmogorov-Smirnov results for Standard Deviation of Speed

Goodness-of-Fit Tests for Normal Distribution				
Test	Statistic		P Value	
Kolmogorov-Smirnov	D	0.207291	Pr > D	<0.010
Cramer-von Mises	W-Sq	13.13642	Pr > W-Sq	<0.005
Anderson-Darling	A-Sq	73.27604	Pr > A-Sq	<0.005

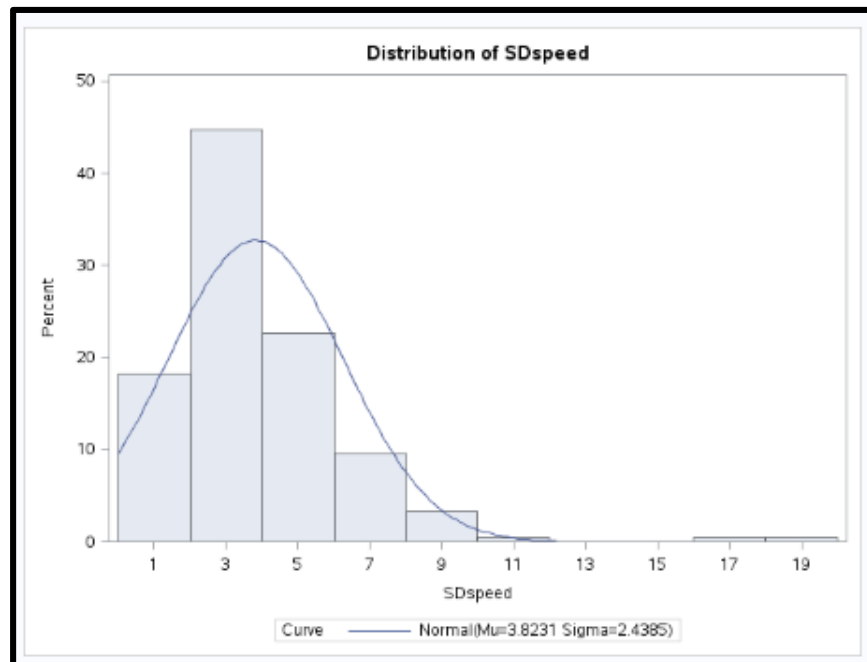

Figure 43. Standard Deviation of Speed Histogram

A series of transformation have been done for the standard deviation of speed variable. These transformations include log transformation, inverse transformation, square transformation, square root transformation, and exponential transformation. Results revealed that Log transformation has the lowest skewness and the kurtosis with 0.105 and 0.06 respectively, which is also less than the skewness and the kurtosis of the untransformed variable which is 1.846 and 2.72, respectively.

When testing the normality for the log standard deviation of speed, from Kolmogorov-Smirnov results to test normality as shown in Table 11 and Figure 44, it can be concluded that there is no significant difference between the distribution of the log standard deviation of speed and normal distribution ( $D=0.0534$ ,  $p>0.15$ ). Consequently, Log standard deviation of speed will be used in the model.

Table 11. Kolmogorov-Smirnov results for Log Standard Deviation of Speed

Goodness-of-Fit Tests for Normal Distribution				
Test	Statistic		P Value	
Kolmogorov-Smirnov	D	0.05349988	Pr > D	>0.150
Cramer-von Mises	W-Sq	0.12864165	Pr > W-Sq	0.047
Anderson-Darling	A-Sq	0.87026151	Pr > A-Sq	0.025

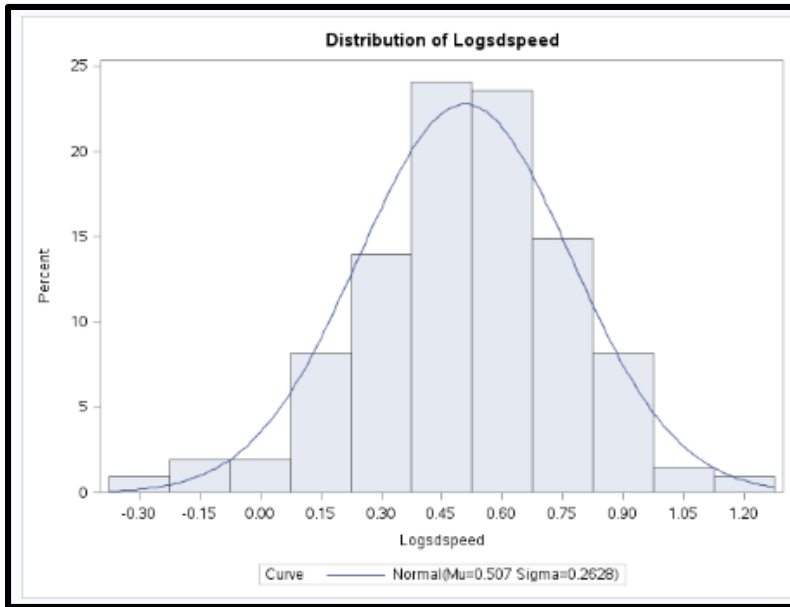

Figure 44. Log Standard Deviation of Speed Histogram

#### 5.6.4.3 Testing Normality for the Standard Deviation of Lane Deviation Variable

Table 12 and Figure 45 show the Kolmogorov-Smirnov results to test normality for the standard deviation of lane deviation variable. It can be concluded that there is no significant difference between the distribution of the standard deviation of lane deviation and the normal distribution ( $D=0.048$ ,  $p>0.15$ ). Consequently, the standard deviation of lane deviation variable does not need transformation.

Table 12. Kolmogorov-Smirnov results for Standard Deviation of Lane Deviation

Goodness-of-Fit Tests for Normal Distribution				
Test	Statistic		P Value	
Kolmogorov-Smirnov	D	0.04850048	Pr > D	>0.15
Cramer-von Mises	W-Sq	0.09105476	Pr > W-Sq	0.149
Anderson-Darling	A-Sq	0.6785015	Pr > A-Sq	0.079



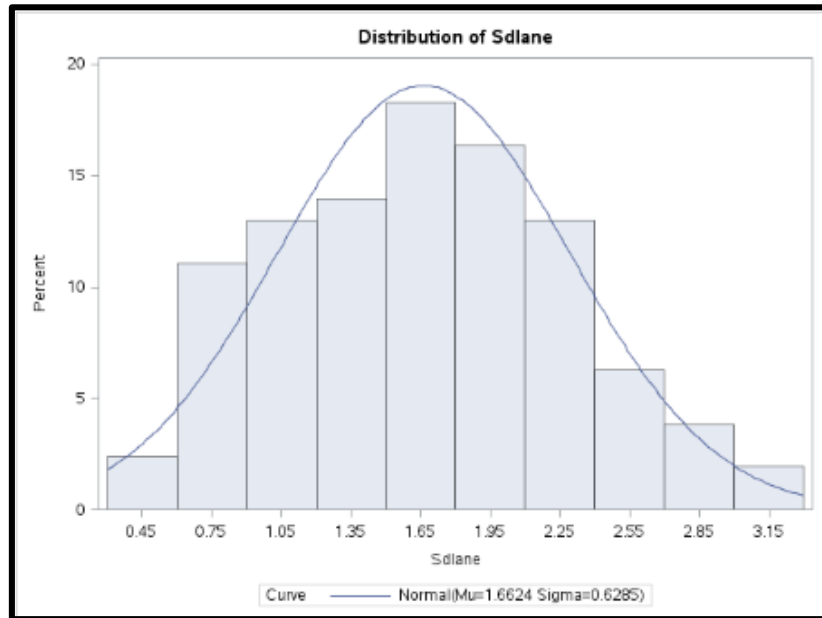

Figure 45. Standard Deviation of Lane Deviation Histogram

5.6.4.4 Testing Normality for Acceleration Variable

Table 13 and Figure 46 show the Kolmogorov-Smirnov results to test normality for acceleration. It can be concluded that there is a significant difference between the distribution of the acceleration variable and the normal distribution ( $D=0.254$ ,  $p<0.01$ ). Consequently, acceleration variable needs transformation.

Table 13. Kolmogorov-Smirnov results for Acceleration

Goodness-of-Fit Tests for Normal Distribution				
Test	Statistic		P Value	
Kolmogorov-Smirnov	D	0.2549615	Pr > D	<0.010
Cramer-von Mises	W-Sq	15.4857079	Pr > W-Sq	<0.005
Anderson-Darling	A-Sq	88.4579362	Pr > A-Sq	<0.005

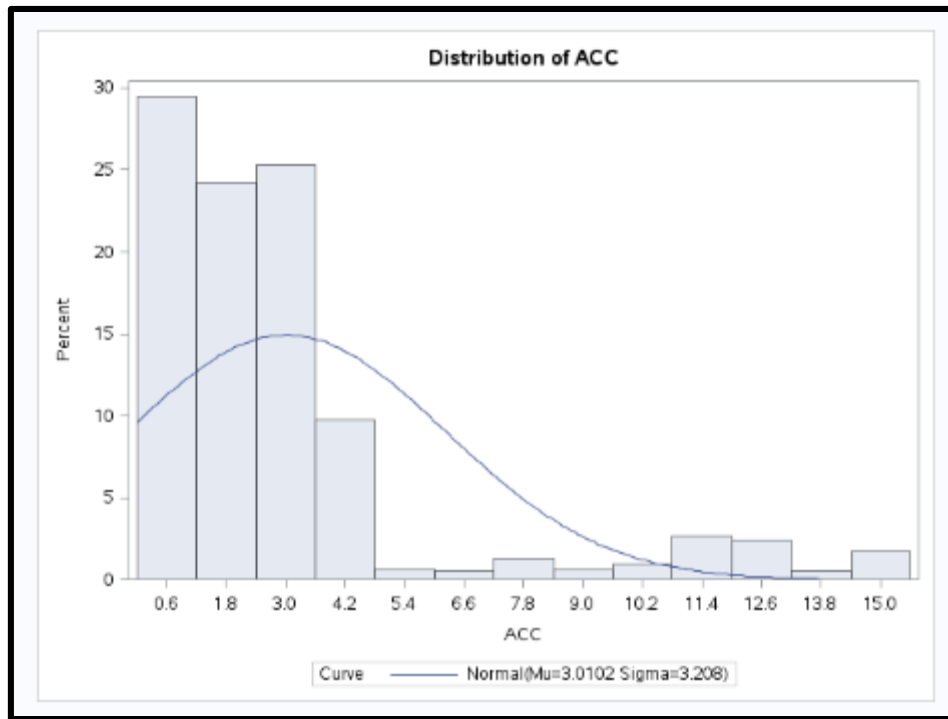

Figure 46. Acceleration Histogram

A series of transformation have been done for the acceleration variable. These transformations include log transformation, inverse transformation, square transformation, square root transformation, and exponential transformation. Results revealed that Log transformation has the lowest skewness and the kurtosis with 0.023 and 0.58 respectively, which is also less than the skewness and the kurtosis of the untransformed variable which is 2.24 and 4.38, respectively.

When testing the normality for the log acceleration, from Kolmogorov-Smirnov results to test normality as shown in Table 14 and Figure 47, it can be concluded that there is a significant difference between the distribution of the log acceleration and the normal distribution ( $D=0.08$ ,  $p<0.01$ ). At this case, it is better to choose the variable that gives the least skewness and kurtosis. Thus, Log acceleration will be used in the model.

Table 14. Kolmogorov-Smirnov results for Log Acceleration

Goodness-of-Fit Tests for Normal Distribution				
Test	Statistic		P Value	
Kolmogorov-Smirnov	D	0.08019487	Pr > D	<0.010
Cramer-von Mises	W-Sq	0.77458251	Pr > W-Sq	<0.005
Anderson-Darling	A-Sq	5.49861256	Pr > A-Sq	<0.005

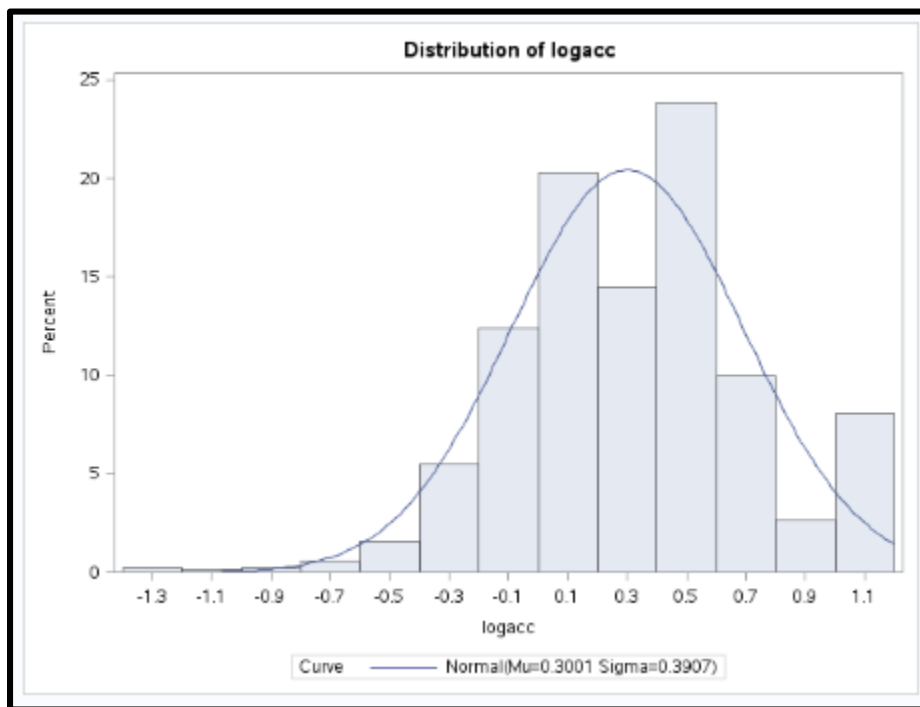

Figure 47. Log Acceleration Histogram

#### 5.6.4.5 Testing Normality for Acceleration Noise Variable

From Kolmogorov-Smirnov results to test normality as shown in Table 15 and Figure 48, it can be concluded that there is a significant difference between the distribution of the acceleration noise and the normal distribution ( $D=0.219$ ,  $p<0.01$ ). Consequently, acceleration noise variable needs transformation.

Table 15. Kolmogorov-Smirnov results for Acceleration Noise

Goodness-of-Fit Tests for Normal Distribution				
Test	Statistic		P Value	
Kolmogorov-Smirnov	D	0.2191225	Pr > D	<0.010
Cramer-von Mises	W-Sq	14.8671311	Pr > W-Sq	<0.005
Anderson-Darling	A-Sq	83.1373101	Pr > A-Sq	<0.005

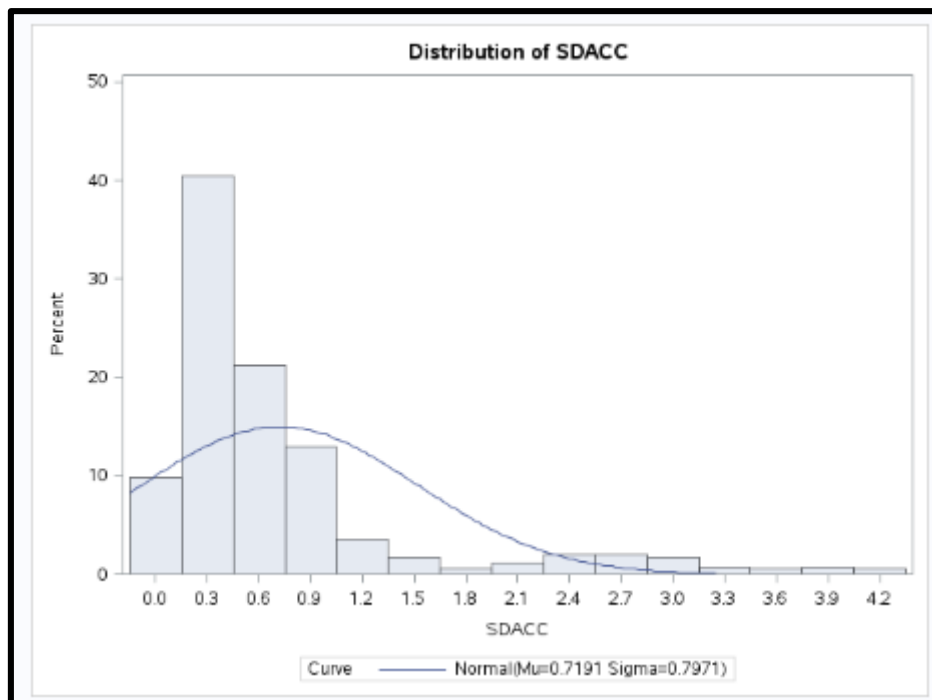

Figure 48. Acceleration Noise Histogram

A series of transformation have been done for the acceleration noise variable. These transformations include log transformation, inverse transformation, square transformation, square root transformation, and exponential transformation. Results revealed that Log transformation has the lowest skewness and the kurtosis with 0.039 and 0.385 respectively, which is also less than the skewness and the kurtosis of the untransformed variable which is 2.3 and 5.15, respectively.

From Kolmogorov-Smirnov results to test normality as shown in Table 16 and Figure 49, it can be concluded that there is no significant difference between the distribution of the log standard deviation of speed and normal distribution ( $D=0.0583$ ,  $p=0.091$ ). Consequently, Log standard deviation of speed will be used in the model.

Table 16. Kolmogorov-Smirnov results for Log Acceleration Noise

Goodness-of-Fit Tests for Normal Distribution				
Test	Statistic		P Value	
Kolmogorov-Smirnov	D	0.05839849	Pr > D	0.091
Cramer-von Mises	W-Sq	0.14156984	Pr > W-Sq	0.032
Anderson-Darling	A-Sq	1.18967063	Pr > A-Sq	<0.005

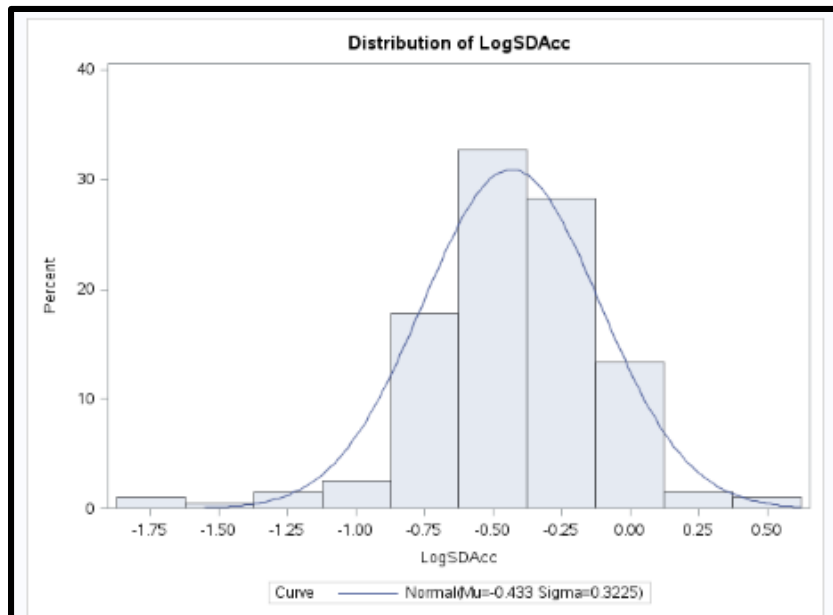

Figure 49. Log Acceleration Noise Histogram

5.6.4.6 Testing Normality for Deceleration Variable

From Kolmogorov-Smirnov results to test normality as shown in Table 17 and Figure 50, it can be concluded that there is a significant difference between the distribution of the deceleration and normal distribution ( $D=0.33, p<0.01$ ). Consequently, acceleration variable needs transformation.

Table 17. Kolmogorov-Smirnov results for Deceleration

Goodness-of-Fit Tests for Normal Distribution				
Test	Statistic		P Value	
Kolmogorov-Smirnov	D	0.331948	Pr > D	<0.010
Cramer-von Mises	W-Sq	22.232385	Pr > W-Sq	<0.005
Anderson-Darling	A-Sq	116.318100	Pr > A-Sq	<0.005

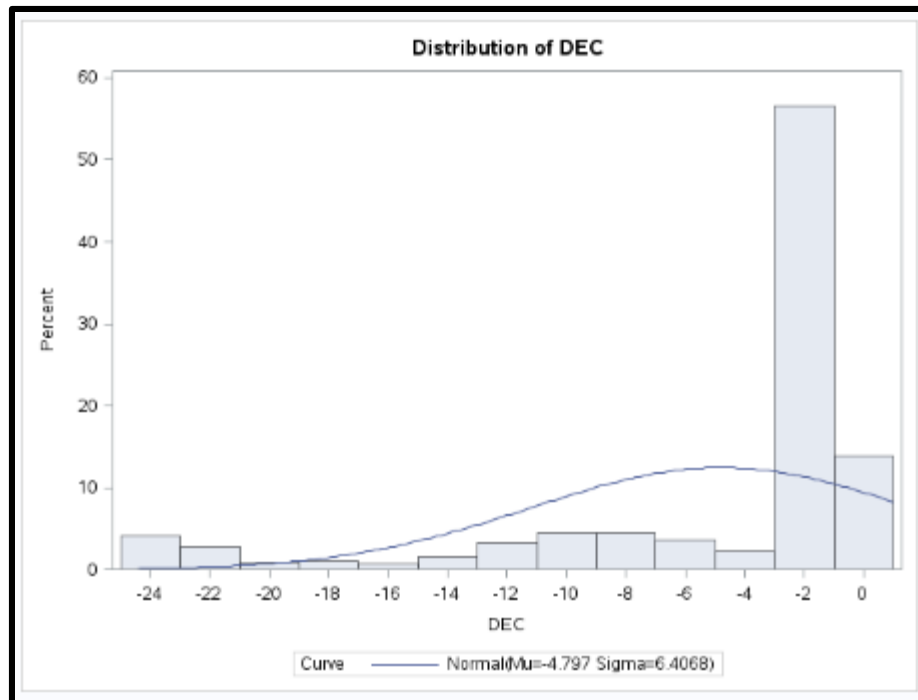

Figure 50. Deceleration Histogram

A series of transformation have been done for the deceleration variable. These transformations include log transformation, inverse transformation, square transformation, square root transformation, and exponential transformation. Results revealed that Log transformation has the lowest skewness and the kurtosis with 0.54 and -0.16 respectively which is also less than the skewness and the kurtosis of the untransformed variable which is -1.86 and 2.3, respectively.

From Kolmogorov-Smirnov results to test normality as shown in Table 18 and Figure 51, it can be concluded that there is also a significant difference between the distribution of the log deceleration and the normal distribution ( $D=0.215$ ,  $p<0.01$ ). Therefore, log deceleration will be used in the model.

Table 18. Kolmogorov-Smirnov results for Log Deceleration

Goodness-of-Fit Tests for Normal Distribution				
Test	Statistic		P Value	
Kolmogorov-Smirnov	D	0.2156425	Pr > D	<0.010
Cramer-von Mises	W-Sq	8.1242383	Pr > W-Sq	<0.005
Anderson-Darling	A-Sq	40.1487863	Pr > A-Sq	<0.005

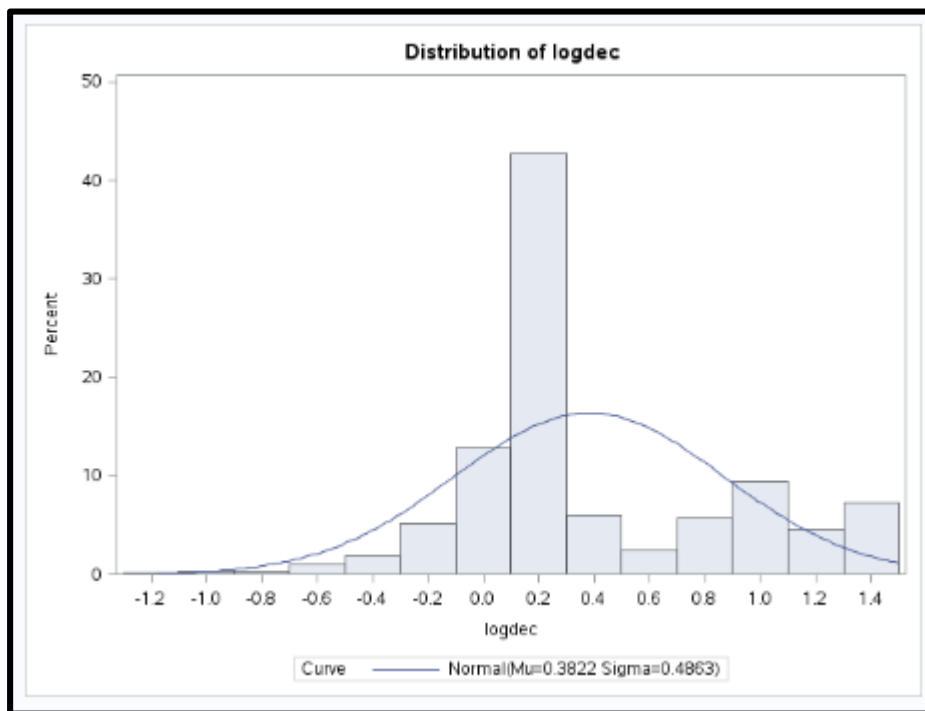

Figure 51. Log Deceleration Histogram



5.6.4.7 Testing Normality for Standard Deviation of Deceleration Variable

From Kolmogorov-Smirnov results to test normality as shown in Table 19 and Figure 52, it can be concluded that there is a significant difference between the distribution of the standard deviation of deceleration and the normal distribution ( $D=0.34$ ,  $p<0.01$ ). Consequently, the standard deviation of deceleration variable needs transformation.

Table 19. Kolmogorov-Smirnov results for Standard Deviation of Deceleration

Goodness-of-Fit Tests for Normal Distribution				
Test	Statistic		P Value	
Kolmogorov-Smirnov	D	0.346888	Pr > D	<0.010
Cramer-von Mises	W-Sq	25.221751	Pr > W-Sq	<0.005
Anderson-Darling	A-Sq	126.27587	Pr > A-Sq	<0.005

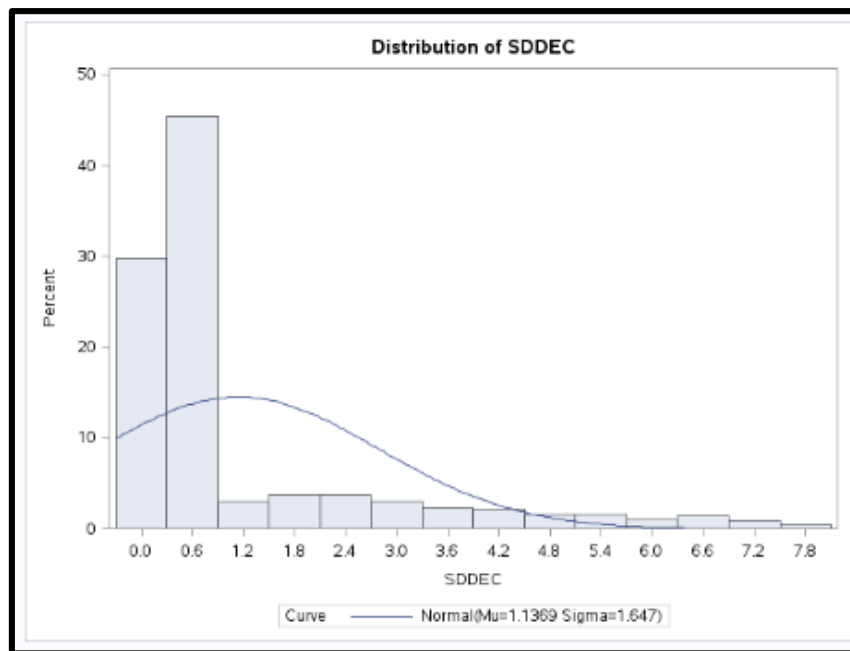

Figure 52. Standard Deviation of Deceleration Histogram

A series of transformation have been done for the standard deviation of deceleration variable. These transformations include log transformation, inverse transformation, square transformation, square root transformation, and exponential transformation. Results revealed that Log transformation has the lowest skewness and the kurtosis with 0.75 and 0.002 respectively, which is also less than the skewness and the kurtosis of the untransformed variable which is 1.6 and 2.7, respectively.

From Kolmogorov-Smirnov results to test normality as shown in Table 20 and Figure 53, it can be concluded that there is also a significant difference between the distribution of log standard deviation of deceleration and the normal distribution ( $D=0.19$ ,  $p<0.01$ ). Thus, it is better to choose the variable that has the lowest skewness. Thus, the log standard deviation of deceleration variable will be used in the model.

Table 20. Kolmogorov-Smirnov results for Log Standard Deviation of Deceleration

Goodness-of-Fit Tests for Normal Distribution				
Test	Statistic		P Value	
Kolmogorov-Smirnov	D	0.1984369	Pr > D	<0.010
Cramer-von Mises	W-Sq	7.4960855	Pr > W-Sq	<0.005
Anderson-Darling	A-Sq	38.5053928	Pr > A-Sq	<0.005

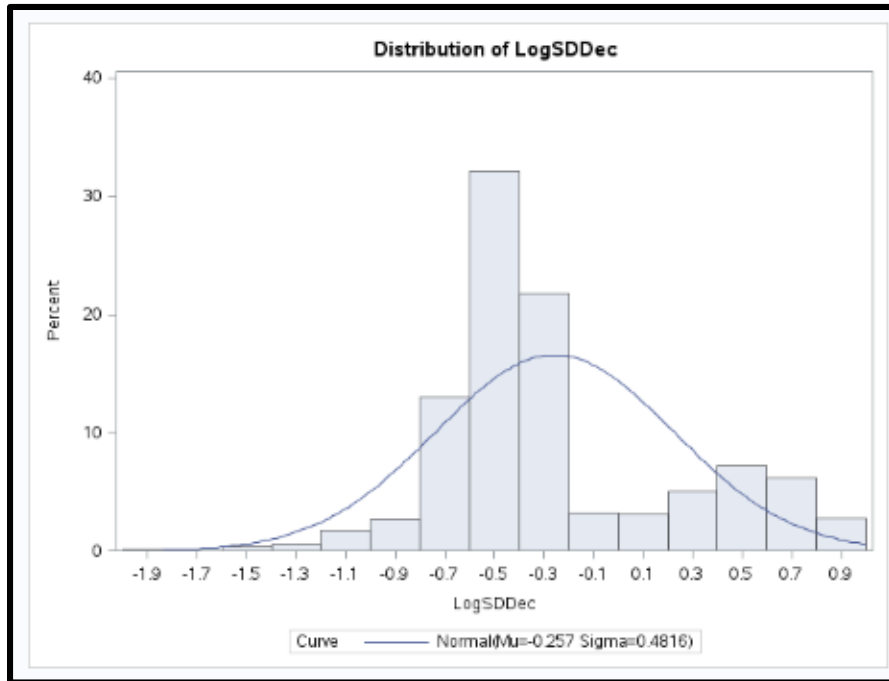

Figure 53. Log Standard Deviation of Deceleration Histogram.

## CHAPTER 6. STATISTICAL METHODOLOGY

In this study, a series of mixed linear regression models with random effects were applied to reveal the contributing factors of risky driving behavior at the toll plaza. The main reason for using random effects is to account for the repeated observations of all subjects in the experiment; random effect models have been widely utilized for this purpose (Laird and Ware, 1982; Lindstrom and Bates, 1988; Zeger and Karim, 1991). The dataset in this study has 832 observations with repeated measurements of the 72 participants; each subject performed three random scenarios, and all the 216 (72 participants \* 3 experiments) observation were repeated for the four different zones, so each participant has 12 repeated measurements, three observations for the different scenarios and four observations for the different zones. Consequently, the random effects method was applied to handle the correlation between measurements of the repeated observations for each participant through all zones; the random effects were reflected by adding the term ( $\theta_i$ ) to the linear regression model.

These series of mixed models consist of two components, the fixed effects and the random effects. The fixed effects can be represented by the fixed intercept  $\alpha_j$  and the fixed vector  $\beta_j$ . The random effects can be represented by the random intercept term  $\theta_i$  for each subject  $i$ . The residual term is  $\varepsilon_{ijt}$ . Assuming that the random intercept  $\theta_i \sim N(0, \sigma_{int}^2)$ , and the residual  $\varepsilon_{ijt} \sim N(0, \sigma_{res}^2)$ . Where,  $\sigma_{int}^2$  and  $\sigma_{res}^2$  are the variances of the random intercept and the residual, respectively. The linear mixed model in this study can be represented by:

$$Y_{ijt} = \alpha_j + \beta_j X_{ijt} + \beta_j X_i + \theta_i + \varepsilon_{ijt}$$

Where:

$i$  is the subject number from 1 to 72,

$j$  is the zone number from zone 1 to zone 4,

$t$  is the number of experiments for each participant from 1 to 3,

$Y_{ijt}$  = response variable (e.g. average speed, speed variation, etc.),

$\alpha_j$  = intercept for each zone from 1 to 4,

$\beta_j$  = coefficients of explanatory variables for zone  $j$ ,

$X_{ijt}$  = explanatory variables for scenario variables (e.g. path, traffic, etc.),

$X_{ijt}$  = explanatory variables for drivers' characteristics (e.g. age, gender, etc.),

$\theta_i$  = random effects term accounting for subject  $i$ , and

$\varepsilon_{ijt}$  = error term.

## CHAPTER 7. MODELING RESULTS AND DISCUSSION

### 7.1 The Linear mixed model results

The models were developed for seven driving behavior variables to investigate the effect of scenario variables (i.e., path, signage, pavement markings, traffic condition, and extending auxiliary lanes) and drivers' characteristics on risky driving behavior at the toll plaza. These variables are average speed, standard deviation of speed, standard deviation of lane deviation, acceleration noise, acceleration rate, deceleration rate, and standard deviation of deceleration (variation of the braking action).

Backward elimination method was used for the variable selection process by starting with the full independent variables and eliminate the most insignificant variable and ending with a set of variables that have a significant influence on the model. Also, AIC (Akaike's Information Criterion) was used in order to compare the models to choose the best model. Better models have smaller AIC value which is defined as follows:

$$AIC = 2 * k - 2 * \ln(L)$$

Where:

k is the number of estimated parameters in the model, and

L is the maximum value of the likelihood function for the model.

In total, seven random intercept models (average speed, the standard deviation of speed, the standard deviation of lane deviation, acceleration noise, acceleration, deceleration, and variation of the braking action) were developed, as shown in Tables 21-27. From the Tables, the

variances of the random intercept for all models are significant which indicate that the random effect models are validated. Moreover, the coefficient of determination (R-squared) has been calculated for all models to measure how the observed values are fitted by the model. Thus, R-squared value is measuring how good is the model.

$$R - squared = 1 - \frac{SSE}{SST}$$

$$SSE = \frac{\sum(Oi - Pi)^2}{N}$$

$$SST = \frac{\sum(Oi - \bar{O}i)^2}{N}$$

Where

N is the sample size.

SSE is the sum of squares due to error.

SST is the total sum of squares.

O<sub>i</sub> is the observed values.

P<sub>i</sub> is the predicted values.

$\bar{O}$  is the mean of the observed values, and

The relation between the driving behavior variables and the path decision-making are shown in the figures in Appendix B. Also, the boxplots of the significant variables for each driver behavior variable are attached in Appendix B.

### 7.1.1 Average Speed Model results

From the presented results in Table 21, when comparing the average speed between different zones, it can be concluded that drivers are more likely to drive with a significantly higher speed at zone 1 and zone 2 before the toll plaza than the toll plaza zone. Also, the result exhibits that there is no significant difference between the average speed at the toll plaza zone and the zone after the toll plaza. Conclusions from the scenario variables are presented as following. First, from the path decision-making's point of view, drivers who navigate in the cash lane paths (e.g. path 2, path 5) and drivers who drive from on-ramps (e.g. path 4, path 5), or drivers who heading to the off-ramp such as path 3, tend to drive with a significantly lower speed than the drivers who drive from the mainline through the ORT and continue in the mainline such as path 1, as shown in Figure 54. Also, it can be inferred that the drivers who navigate through the cash booths have a significantly lower average speed than the drivers who use the ORT by 30 mph at the toll plaza zone. Second, arrow pavement markings have considerable influence on increasing vehicle's average speed at the toll plaza zone. Third, the result indicates that average speed decreases with congestion before the toll plaza zones. Fourth, extending auxiliary lanes before or after the toll plaza have a significant effect on decreasing vehicles' average speed after and before the toll plaza. Moreover, extending the auxiliary lanes length after the toll plaza has a marked effect on increasing vehicles' average speed at the toll plaza zone. On the other hand, the result reveals the effect of the driver characteristic on the average speed. First, drivers with lower driving frequency (less than five trips per week) have significantly lower average speed than higher driving frequency drivers (more than three trips per day). Second, the results indicated that drivers who are familiar with the ETC-tag have significantly higher speed than other drivers after the toll plaza zone. Third, the results suggested that drivers with higher education level (higher than bachelor) have considerably



lower average speed than other drivers (drivers with bachelor or lower). Fourth, lower annual income drivers (lower than \$40000 annually) have significantly higher speed than other drivers (with an annual income equal to \$40000 or higher) before the toll plaza zones.

Table 21. Average Speed Model for Each Zone

Average Speed		Zone1	Zone2	Zone3	Zone4
		Estimate(p-value)	Estimate (p-value)	Estimate (p-value)	Estimate (p-value)
Intercept		<b>64.231** (&lt;0.0001)</b>			
Zonal Intercept		5.452* (<0.092)	<b>11.65** (&lt;0.0003)</b>	-	0.917 (<0.806)
Path	Path 2 (vs. Path 1)	-0.725 (0.678)	-0.524 (0.765)	<b>-30.807** (&lt;0.0001)</b>	<b>-3.916** (0.030)</b>
	Path 3 (vs. Path 1)	<b>-4.195* (0.016)</b>	<b>-5.195** (0.003)</b>	<b>-4.017** (0.024)</b>	-0.393 (0.827)
	Path 4 (vs. Path 1)	<b>-4.512* (0.004)</b>	<b>-3.222** (0.042)</b>	<b>-5.248** (0.001)</b>	<b>-5.197** (0.002)</b>
	Path 5 (vs. Path 1)	<b>-4.545* (0.004)</b>	<b>-3.435** (0.031)</b>	<b>-30.765** (&lt;0.0001)</b>	-2.012 (0.210)
Traffic condition	Peak (vs. Off-Peak)	<b>-2.8* (0.005)</b>	<b>-6.12** (&lt;0.0001)</b>	-	-
Pavement markings	Yes (vs. No)	-	-	1.856* (0.064)	-
Signage	Add DMS (vs. Base)	-	-0.903 (0.557)	-	-
	Remove 3 <sup>rd</sup> sign (vs. Base)	-	<b>2.16** (0.040)</b>	-	-
Extending auxiliary lanes	After toll plaza (vs. Base)	-	-	<b>2.553** (0.041)</b>	<b>-3.515** (0.005)</b>
	Before toll plaza (vs. Base)	-	-	-0.868 (0.480)	<b>-3.19** (0.012)</b>
Driving frequency	1 to 5 per week (vs. More than 3 trips per day)	-	-	-	-2.69* (0.074)
	1 or 2 trips per day (vs. More than 3 trips per day)	-	-	-	0.912 (0.503)
ETC-tag use	Yes (vs. No)	-	-	-	<b>4.012** (0.005)</b>
Education	Higher than bachelor (vs. bachelor or lower)	-	-	<b>-2.92** (0.014)</b>	<b>-2.778** (0.022)</b>
Annual income	lower than \$40000 (vs. \$40000 or higher)	<b>2.608** (0.0617)</b>	<b>2.32** (0.033)</b>	-	-
Variance of random intercept ( $\theta_i$ )		<b>3.421** (0.0006)</b>			
Variance of residual ( $\epsilon_{ij}$ )		<b>19.09** (&lt;0.0001)</b>			
Goodness of fit measures		-2LL=5553.33, AIC= 5546.34, BIC = 5550.88, and R-squared=0.65			

\*\* Significant at 5% (bold values), \* significant at 10% level, and others are significant only at 10%.

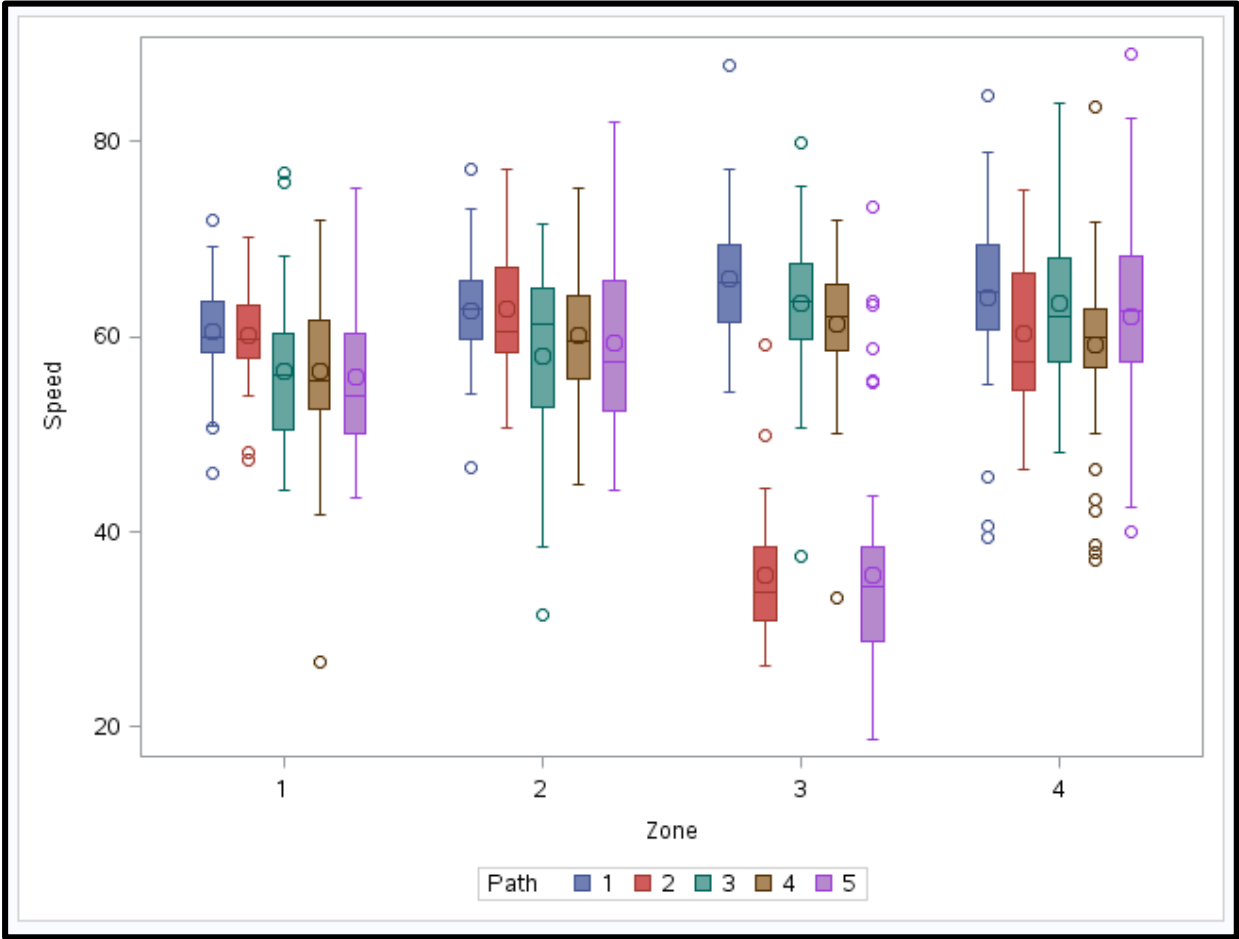

Figure 54. Box Plot of the Relation between Average Speed at each Zone for each Path

### 7.1.2 Log Standard deviation of Speed Model results

From the results in Table 22, when comparing the speed variation between the four zones, it can be concluded that drivers tend to drive with a significantly higher speed variation at the toll plaza zone than the zone after the toll plaza. Also, the result illustrates that there is no significant difference in the speed variation between the zones before the toll plaza (zone 1, and zone 2) and the toll plaza zone. Conclusions from the scenario variables are presented as following. First, the effect of the different paths on the speed variation. Drivers tend to drive with a significantly higher speed variation at path 2, path 3, path 4, and path 5 than at path 1, as shown in Figure 55. Also, it can be inferred that the drivers who navigate through the cash booths have significantly higher speed variation than the drivers who use the ORT at the toll plaza zone. Second, arrow pavement markings have a significant effect on mitigating speed variation at the toll plaza zone by 7.6%. Third, the result shows that speed variation decreases with congestion by 11% at the first zone and by 9% at the toll plaza zone. Fourth, extending auxiliary lanes after or before the toll plaza have a significant effect on decreasing vehicles' speed variation at the toll plaza zone by 14% and 11.4%, respectively. Also, extending the auxiliary lanes length after the toll plaza has a significant effect on increasing vehicles' speed variation after the toll plaza zone by 22%. Fifth, the third case of signage which is removing the third overhead sign has an effect on reducing speed variation than the base condition case by 12% and 8% at the first zone and the second zone before the toll plaza, respectively. Likewise, the second case of signage which is removing the third overhead sign and adding DMS on the on-ramp has a significant impact on reducing speed variation by 9% in the first zone. On the other hand, the result illustrates the effect of the driver characteristic on the speed variation. First, the results indicated that female drivers drive with lower speed variation by 8% at the first zone. Second, young drivers (18-25 years old) and old drivers (more than 60 years old)

tend to drive with a higher speed variation than middle age drivers (35 to 50 years old) by 10% and 17%, respectively, after the toll plaza zone. Third, drivers with crash experience exhibit higher speed variation than other drivers by 14% after the toll plaza zone.

Table 22. Log Standard Deviation of Speed Model for Each Zone

Log Standard Deviation of Speed		Zone1	Zone2	Zone3	Zone4
		Estimate (p-value)	Estimate (p-value)	Estimate (p-value)	Estimate (p-value)
Intercept		<b>0.759** (&lt;0.001)</b>			
Zonal Intercept		-0.05 (<0.675)	<b>-0.315** (0.003)</b>	-	<b>-0.572** (&lt;0.0001)</b>
Path	Path 2 (vs. Path 1)	0.033 (0.613)	<b>0.182** (0.005)</b>	<b>0.854** (&lt;0.0001)</b>	<b>0.293** (&lt;0.0001)</b>
	Path 3 (vs. Path 1)	0.085 (0.188)	0.042 (0.518)	<b>0.235** (0.001)</b>	<b>0.135** (0.041)</b>
	Path 4 (vs. Path 1)	<b>0.252** (0.0001)</b>	<b>0.151** (0.019)</b>	0.085 (0.147)	<b>0.175** (0.003)</b>
	Path 5 (vs. Path 1)	<b>0.275** (&lt;0.0001)</b>	<b>0.140** (0.033)</b>	<b>0.800** (&lt;0.0001)</b>	<b>0.234** (&lt;0.0001)</b>
Traffic condition	Peak (vs. Off-Peak)	<b>-0.104** (0.005)</b>	-	<b>-0.090** (0.017)</b>	-
Pavement markings	Yes (vs. No)	-	-	<b>-0.074** (0.046)</b>	-
Extending auxiliary lanes	After toll plaza (vs. Base)	-	-	<b>-0.127** (0.006)</b>	<b>0.205** (&lt;0.0001)</b>
	Before toll plaza (vs. Base)	-	-	<b>-0.109** (0.020)</b>	-0.071 (0.127)
Signage	Add DMS (vs. Base)	-0.086* (0.091)	-0.071 (0.22)	-	-
	Remove 3 <sup>rd</sup> sign (vs. Base)	<b>-0.111** (0.013)</b>	-0.079* (0.081)	-	-
Gender	Female (vs. Male)	<b>-0.081** (0.049)</b>	-	-	-
Age	18-25 (vs. 35-50)	-	-	-	0.09* (0.081)
	25-35 (vs. 35-50)	-	-	-	0.020 (0.737)
	50-60 (vs. 35-50)	-	-	-	0.031 (0.705)
	60 or more (Vs. 35-50)	-	-	-	0.158 (0.068)
Crash experience	Yes (vs. No)	-	-	-	<b>0.135** (0.016)</b>
Variance of random intercept ( $\theta_i$ )		<b>3.247** (0.0012)</b>			
Variance of residual ( $\epsilon_{ij}$ )		<b>19.0571** (&lt;0.0001)</b>			
Goodness of fit measures		-2LL=321.04, AIC= 325.04, BIC = 329.59, and R-squared=0.52			

\*\* Significant at 5% (bold values), \* significant at 10% level, and others are significant only at 10%.

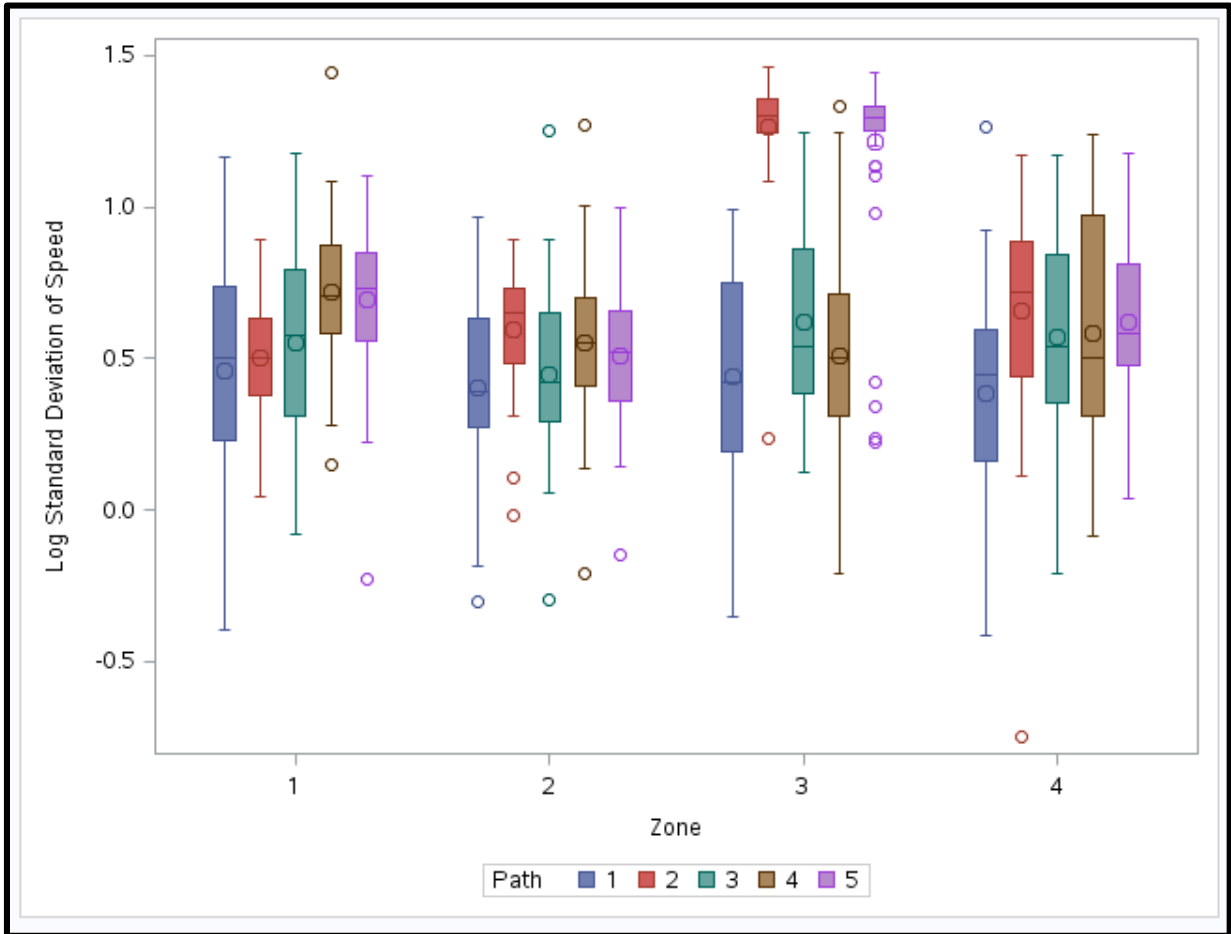

Figure 55. Box Plot of the Relation between Log Standard Deviation of Speed at each Zone for each Path

### 7.1.3 Standard Deviation of Lane Deviation Model results

Table 23 shows the modeling result of the standard deviation of lane deviation. It can be concluded that drivers tend to drive with a significantly higher lane deviation at the zone after the toll plaza than the toll plaza zone. Also, the result shows that there is no significant difference between the lane deviation at the zones before the toll plaza (zone 1, and zone 2) and the toll plaza zone. Conclusions from the scenario variables are presented as following. First, from the path decision-making point of view, drivers tend to drive at path 2, path 3, path 4, and path 5 with a significantly higher standard deviation of lane deviation than the base condition (path 1), as shown in Figure 56. Second, arrow pavement markings have a significant effect on reducing the standard deviation of lane deviation before the toll plaza at the first two zones. Third, the result indicates that the standard deviation of lane deviation decreases with congestion before the toll plaza zones. Fourth, extending auxiliary lanes before or after the toll plaza have a significant influence on decreasing the standard deviation of lane deviation than the base condition at first and second zones. Fifth, the third case of signage which is removing the third overhead sign has an effect on reducing the standard deviation of lane deviation than the base condition case after the toll plaza zone. On the other hand, the modeling result reveals the effect of the driver characteristic on the standard deviation of lane deviation. Drivers with lower driving frequency (one or two trips per day) have a lower standard deviation of lane deviation than the high driving frequency drivers who exhibit more than three trips per day in the first zone.



Table 23. Standard Deviation of Lane Deviation Model for Each Zone

Standard Deviation of Lane Deviation		Zone1	Zone2	Zone3	Zone4
		Estimate (p-value)	Estimate (p-value)	Estimate (p-value)	Estimate (p-value)
Intercept		<b>1.2369** (&lt;0.0001)</b>			
Zonal Intercept		0.1849 (0.426)	0.1553 (0.4888)	-	<b>1.069** (&lt;0.0001)</b>
Path	Path 2 (vs. Path 1)	<b>0.903** (&lt;0.0001)</b>	<b>0.506** (0.001)</b>	<b>0.869** (&lt;0.0001)</b>	<b>1.011** (&lt;0.0001)</b>
	Path 3 (vs. Path 1)	<b>0.364** (0.013)</b>	<b>0.255** (0.074)</b>	<b>0.446** (0.002)</b>	<b>0.907** (&lt;0.0001)</b>
	Path 4 (vs. Path 1)	<b>1.329** (&lt;0.0001)</b>	<b>0.488** (0.0002)</b>	-0.031 (0.824)	-0.039 (0.782)
	Path 5 (vs. Path 1)	<b>0.823** (&lt;0.0001)</b>	<b>0.354** (0.006)</b>	<b>0.627** (&lt;0.0001)</b>	<b>0.800** (&lt;0.0001)</b>
Traffic condition	Peak (vs. Off-Peak)	<b>-0.303** (0.0003)</b>	<b>-0.174** (0.035)</b>	-	-
Pavement markings	Yes (vs. No)	-0.151* (0.069)	<b>-0.177** (0.032)</b>	-	-
Extending auxiliary lanes	After toll plaza (vs. Base)	-0.175* (0.087)	-	-	-
	Before toll plaza (vs. Base)	-0.184* (0.074)	-	-	-
Signage	Add DMS (vs. Base)	-	-	-	-0.046 (0.717)
	Remove 3 <sup>rd</sup> sign (vs. Base)				-0.181* (0.063)
Driving frequency	1 to 5 per week (vs. More than 3 trips per day)	0.207* (0.069)	-	-	-
	1 or 2 trips per day (vs. More than 3 trips per day)	<b>-0.287** (0.009)</b>	-	-	-
Variance of random intercept ( $\theta_i$ )		<b>2.507** (0.012)</b>			
Variance of residual ( $\epsilon_{ij}$ )		<b>19.141** (&lt;0.0001)</b>			
Goodness of fit measures		-2LL=1561.22, AIC= 1565.22, BIC = 1569.78, and R-squared=0.42			

\*\* Significant at 5% (bold values), \* significant at 10% level, and others are significant only at 10%.

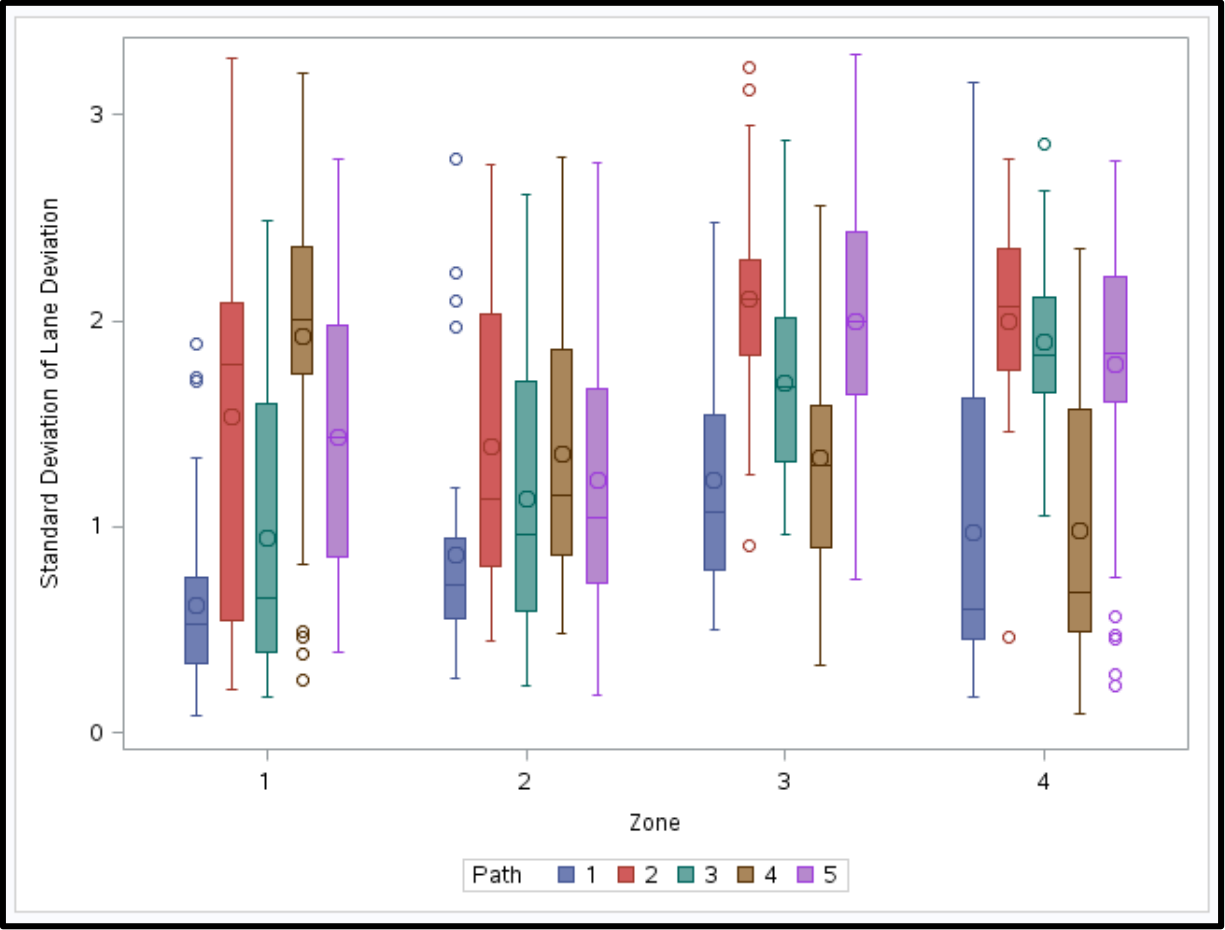

Figure 56. Box Plot of the Relation between the Standard Deviation of Lane Deviation at each Zone for each Path

#### 7.1.4 Log Acceleration Noise Model results

The modeling result of the acceleration noise can be revealed from Table 24. When comparing the acceleration noise between the different zones, it can be concluded that drivers are more likely to have a significantly higher acceleration noise at the toll plaza zone than after the toll plaza zone. Also, the result shows that there is no significant difference in the acceleration between the zones before the toll plaza (zone 1, and zone 2) and the toll plaza zone. Conclusions from the scenario variables are presented as following. First, in terms of path decision-making, subjects drive with a significantly higher acceleration noise at path 2, path 3, path 4, and path 5 than at path one which is the driving at the mainline through the open road tolling system. Figure 57 exhibits acceleration noise boxplots for each path at each zone. Second, arrow pavement markings have a significant effect on reducing acceleration noise before the toll plaza zone by 9%. Third, the result shows that drivers navigate with a lower acceleration noise at peak-hour traffic conditions by 10% after the toll plaza zone than the drivers who drive in the off-peak traffic conditions. Fourth, extending auxiliary lanes after or before the toll plaza have a significant influence on increasing vehicles' acceleration noise than the base condition by 22% and 12%, respectively. Fifth, the third case of signage which is removing the third overhead sign has an effect on reducing acceleration noise by 18% than the base condition case at the first zone. In addition, the result shows the effect of the driver characteristic on the acceleration noise. First, the result uncovers that female drivers exhibit a significant lower acceleration noise by 8% in the first zone. Second, young drivers (18-25 years old) and old drivers (50 to 60 years old) drive with significantly higher acceleration noise than middle age drivers (35 to 50 years old) by 16% and 18%, respectively at the first zone. Also, old drivers (50 to 60 years old) have a considerably higher acceleration noise than middle age drivers before the toll plaza zone. Likewise, old drivers (more

than 60 years old) have significantly higher acceleration noise than middle age drivers after the toll plaza zone. Third, drivers with lower driving frequency (one or two trips per day) have a significant lower acceleration noise than the high driving frequency drivers who make more than three trips per day before the toll plaza zone.

Table 24. Log Acceleration Noise Model for Each Zone

Log Acceleration Noise		Zone1	Zone2	Zone3	Zone4
		Estimate (p-value)	Estimate (p-value)	Estimate (p-value)	Estimate (p-value)
Intercept		<b>-0.5941** (&lt;0.0001)</b>			
Zonal Intercept		0.062 (0.5099)	0.1278 (0.2518)	-	<b>-0.2699** (0.0134)</b>
Path	Path 2 (vs. Path 1)	0.141* (0.060)	0.085 (0.254)	<b>0.916** (&lt;0.0001)</b>	<b>0.280** (0.0002)</b>
	Path 3 (vs. Path 1)	<b>0.179** (0.015)</b>	<b>0.178** (0.015)</b>	<b>0.154** (0.038)</b>	0.115 (0.140)
	Path 4 (vs. Path 1)	<b>0.291** (&lt;0.0001)</b>	<b>0.187** (0.005)</b>	0.074 (0.266)	<b>0.178** (0.008)</b>
	Path 5 (vs. Path 1)	<b>0.392** (&lt;0.0001)</b>	0.050 (0.454)	<b>0.964** (&lt;0.0001)</b>	<b>0.222** (0.001)</b>
Traffic condition	Peak (vs. Off-Peak)	-	-	-	<b>0.095** (0.027)</b>
Pavement markings	Yes (vs. No)	-	<b>-0.0854** (0.0477)</b>	-	-
Extending auxiliary lanes	After toll plaza (vs. Base)	-	-	-	<b>0.205** (0.0001)</b>
	Before toll plaza (vs. Base)	-	-	-	<b>0.109** (0.041)</b>
Signage	Add DMS (vs. Base)	-0.0235 (0.724)	-	-	-
	Remove 3 <sup>rd</sup> sign (vs. Base)	<b>-0.1678** (0.001)</b>	-	-	-
Gender	Female (vs. Male)	-0.0815* (0.092)	-	-	-
Age	18-25 (vs. 35-50)	<b>0.148** (0.031)</b>	0.011 (0.868)	-	0.0257 (0.709)
	25-35 (vs. 35-50)	0.064 (0.351)	0.093 (0.179)	-	-0.097 (0.156)
	50-60 (vs. 35-50)	0.189* (0.053)	<b>0.211** (0.033)</b>	-	-0.017 (0.862)
	60 or more (Vs. 35-50)	0.168 (0.112)	0.149 (0.148)	-	0.201* (0.059)
Driving frequency	1 to 5 per week (vs. More than 3 trips per day)	-	<b>-0.122** (0.042)</b>	-	-
	1 or 2 trips per day (vs. More than 3 trips per day)	-	-0.055 (0.329)	-	-
Variance of random intercept ( $\theta_i$ )		<b>3.580** (0.0004)</b>			
Variance of residual ( $\varepsilon_{ij}$ )		<b>18.915** (&lt;0.0001)</b>			
Goodness of fit measures		-2LL=525.70, AIC= 529.7, BIC = 534.25, and R-squared=0.54			

\*\* Significant at 5% (bold values), \* significant at 10% level, and others are significant only at 10%.

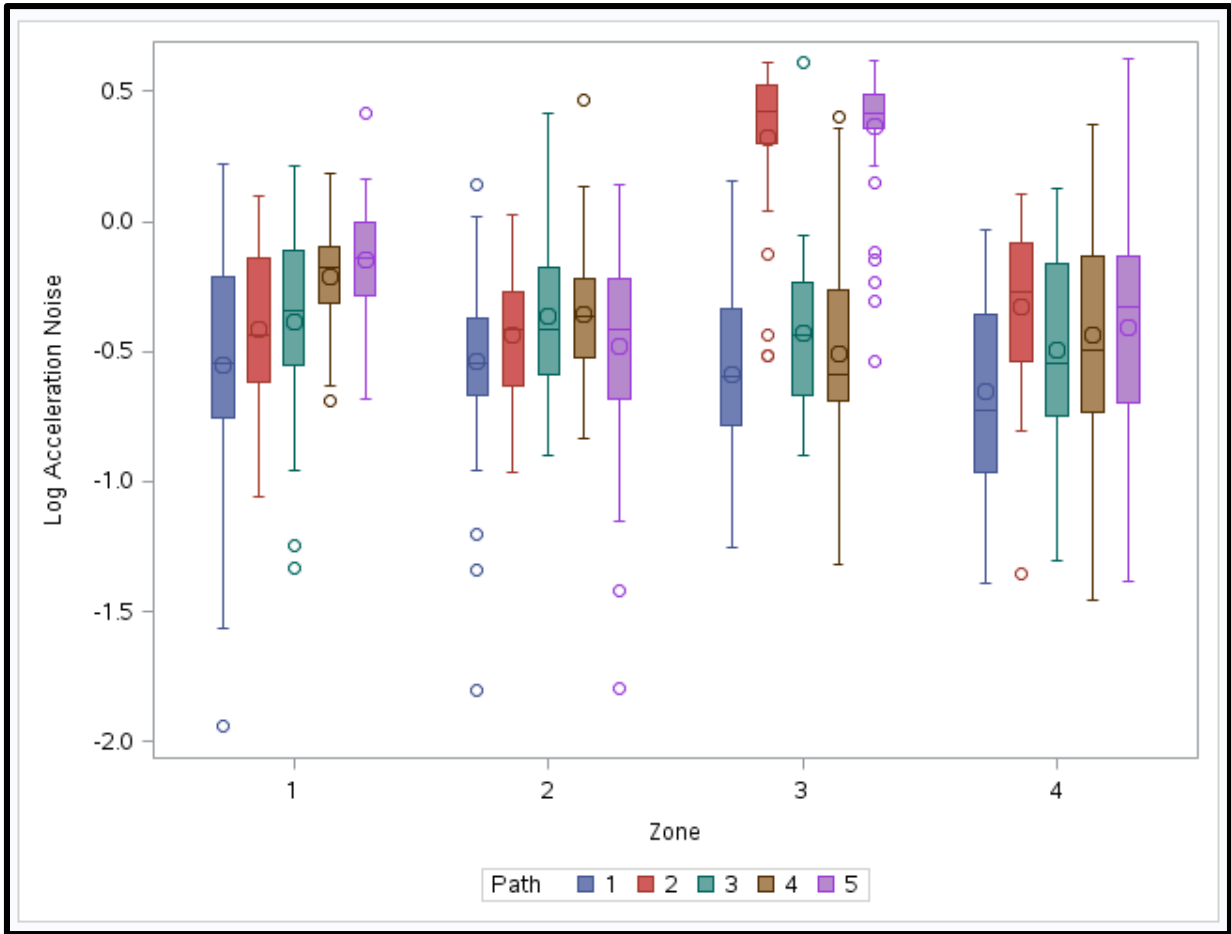

Figure 57. Relation between Log Acceleration Noise at each Zone for each Path

### 7.1.5 Log Acceleration Model results

Table 25 represents the modeling result for the acceleration variable, when comparing the acceleration noise between the different zones, it can be concluded that drivers are more likely to drive with a significantly higher acceleration at the toll plaza zone than after the toll plaza zone. Also, the result shows that there is no significant difference in the acceleration between the zones before the toll plaza (zone 1, and zone 2) and the toll plaza zone. Conclusions for scenario variables can be drawn in several steps. First, from path decision-making point of view, drivers tend to drive at path 2, path 3, path 4, and path 5 with a significantly higher acceleration rate than the ORT path at the mainline (path 1), as shown in Figure 58. Second, arrow pavement markings have a significant effect on reducing vehicle's acceleration rate before the toll plaza zone by 7.4%. Third, drivers who drive at the congested traffic conditions tend to have a significant more acceleration rate than drivers who drive at the uncongested traffic conditions after the toll plaza zone. Fourth, extending auxiliary lanes after or before the toll plaza have a significant influence on increasing vehicles' acceleration rate than the base condition by 17% and 9%, respectively. Fifth, the third case of signage which is removing the third overhead sign has an effect on reducing vehicles' acceleration rate by 17% than the base condition case at the first zone. Moreover, the result reveals the effect of the driver characteristic on the acceleration rate. First, the results indicated that female drivers tend to drive with a significant lower acceleration rate by 13%, 10%, and 9% for zone 1, zone 2, and zone 3, respectively. Second, young drivers (18-25 years old) and old drivers (50 to 60 years old) navigate with significantly higher acceleration than middle age drivers (35 to 50 years old) by 11% and 17%, respectively, at the first zone after the merge area of the on-ramp and the mainline. Third, drivers with driving frequency less than five trips per week and drivers who have a driving frequency of one or two trips per day have a significant lower acceleration rate than

the drivers who have a driving frequency more than 3 trips per day by 13% and 2%, respectively, at the toll plaza zone. Finally, drivers with crash experience exhibit a significant higher acceleration rate than other drivers by 12% after the toll plaza zone.



Table 25. Log Acceleration Model for Each Zone

Log Acceleration		Zone1	Zone2	Zone3	Zone4
		Estimate(p-value)	Estimate (p-value)	Estimate (p-value)	Estimate (p-value)
Intercept		0.1332 (0.3084)			
Zonal Intercept		-0.2306 (0.2176)	-0.237 (0.2339)	-	<b>-0.385** (0.0344)</b>
Path	Path 2 (vs. Path 1)	<b>0.155** (0.0222)</b>	0.0580 (0.3943)	<b>0.8626** (&lt;.0001)</b>	<b>0.293** (&lt;.0001)</b>
	Path 3 (vs. Path 1)	<b>0.133** (0.0463)</b>	<b>0.137** (0.0395)</b>	<b>0.1371** (0.0418)</b>	<b>0.172** (0.0137)</b>
	Path 4 (vs. Path 1)	<b>0.335** (&lt;.0001)</b>	<b>0.162** (0.0078)</b>	0.04592 (0.4482)	<b>0.131** (0.0293)</b>
	Path 5 (vs. Path 1)	<b>0.389** (&lt;.0001)</b>	0.0331 (0.5889)	<b>0.9305** (&lt;.0001)</b>	<b>0.242** (&lt;.0001)</b>
Traffic Condition	Peak (vs. Off-Peak)	-	0.0683* (0.0785)	-	<b>0.0837** (0.0315)</b>
Pavement Markings	Yes (vs. No)	-	-0.0714* (0.0648)	-	-
Extending Auxiliary Lanes	After toll plaza (vs. No change)	-	-	-	<b>0.157** (0.0011)</b>
	Before toll plaza (vs. No change)	-	-	-	<b>0.0871** (0.0707)</b>
Signage	Add DMS (vs. Base)	-0.05271 (0.3784)	-	-	-
	Remove 3 <sup>rd</sup> sign (vs. Base)	<b>-0.157** (0.0006)</b>	-	-	-
Gender	Female (vs. Male)	<b>-0.124** (0.0072)</b>	<b>-0.095** (0.032)</b>	<b>-0.0867** (0.049)</b>	-
Age	18-25 (vs. 35-50)	0.1035* (0.0857)	-	-	-
	25-35 (vs. 35-50)	0.07493 (0.2266)	-	-	-
	50-60 (vs. 35-50)	0.1555* (0.0707)	-	-	-
	60 or more (Vs. 35-50)	0.07899 (0.3985)	-	-	-
Driving Frequency	1 to 5 trips per week (vs. $\geq$ 3 trips per day)	-	-	<b>-0.1238** (0.0216)</b>	-
	1 or 2 trips per day (vs. $\geq$ 3 trips per day)	-	-	-0.0231 (0.6518)	-
Crash Experience	Yes (vs. No)	-	-	-	<b>0.1101** (0.0478)</b>
Variance of random intercept ( $\theta_i$ )		<b>3.682** (0.00025)</b>			
Variance of residual ( $\epsilon_{ij}$ )		<b>18.88** (&lt;0.0001)</b>			
Goodness of fit measures		-2LL=370.45, AIC= 374.45, BIC =379.01, R-squared=0.58			

\*\* Significant at 5% (bold values), \* significant at 10% level, and others are significant only at 10%.

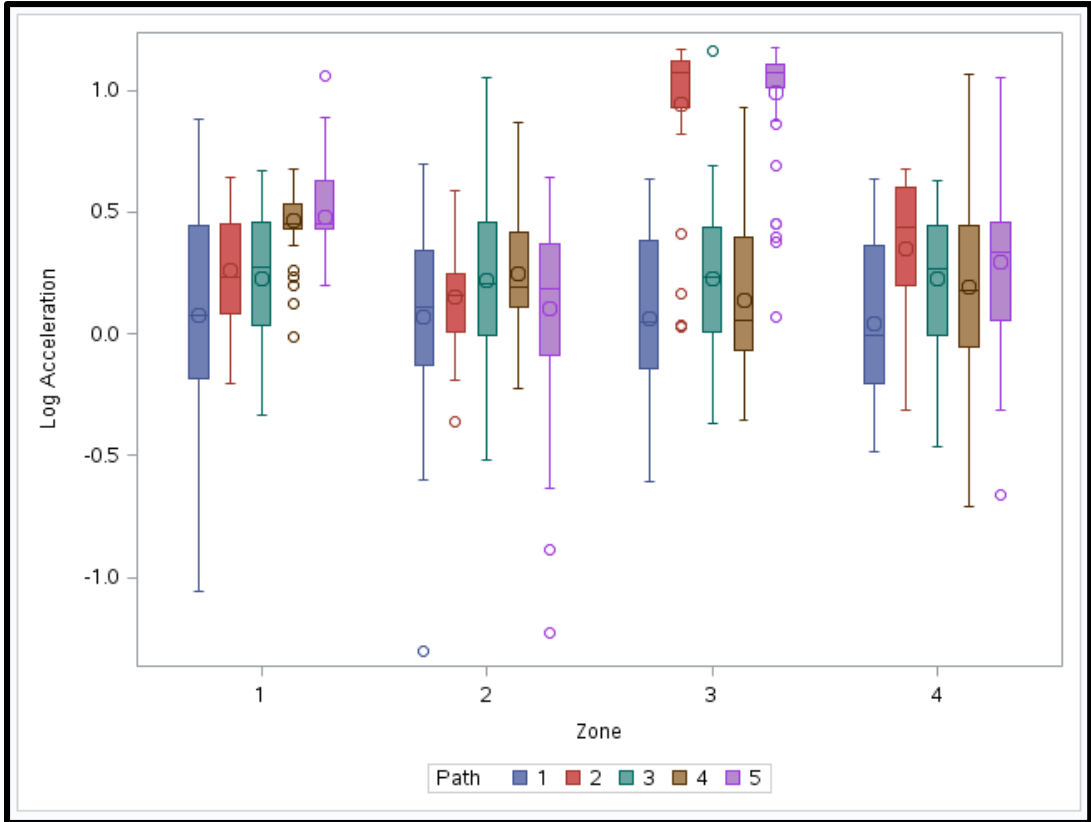

Figure 58. Relation between Log Acceleration at each Zone for each Path

### 7.1.6 Log Deceleration Model results

From deceleration results in Table 26, when comparing the deceleration between the different zones, it can be concluded that there is no significant difference between the deceleration at the toll plaza zone and the other zones (zone 1, zone 2, and zone 3). Also, the result uncovered important conclusions for the scenario variables. First, from path decision-making point of view, participants drive with a significantly higher deceleration rate at path 2, path 3, path 4, and path 5 than path 1, as shown in Figure 59. Second, arrow pavement markings have a significant effect on reducing vehicles' deceleration rate before the toll plaza zone by 10.5%. Third, drivers who navigate at the peak hour traffic condition tend to have a significant lower deceleration rate than other drivers at the toll plaza zone. Fourth, extending auxiliary lanes after the toll plaza has a significant effect on increasing vehicles' deceleration rate than the base condition after the toll plaza by 22%. Fifth, the third case of signage which is removing the third overhead sign has a significant impact on reducing vehicles' deceleration rate by 18% and 11% than the base condition case for the first zone and the second zone, respectively. Furthermore, the result uncovers the effect of the driver characteristic on the deceleration rate. First, young drivers (18-25 years old) and old drivers (50 to 60 years old) drive with a significant higher deceleration rate than middle age drivers (35 to 50 years old) by 19% and 34%, respectively, at the first zone after the merge area of the on-ramp and the mainline. Second, drivers with crash experience exhibit higher deceleration rate than other drivers by 19% after the toll plaza zone. Lastly, the result shows that female drivers exhibit lower deceleration rate by 13%, 10%, and 9% for the first zone, the second zone, and the third zone, respectively.

Table 26. Log Deceleration Model for Each Zone

Log Deceleration		Zone1	Zone2	Zone3	Zone4
		Estimate (p-value)	Estimate (p-value)	Estimate (p-value)	Estimate (p-value)
Intercept		<b>0.3868** (0.0005)</b>			
Zonal Intercept		-0.205 (0.1529)	0.02795 (<0.8371)	-	0.1261 (0.1816)
Path	Path 2 (vs. Path 1)	0.0076 (0.9363)	-	<b>0.881** (&lt;.0001)</b>	0.1693* (0.0784)
	Path 3 (vs. Path 1)	0.173* (0.0624)	-	0.1544* (0.09)	<b>0.446** (&lt;.0001)</b>
	Path 4 (vs. Path 1)	0.063 (0.518)	-	0.0673 (0.4449)	<b>0.169** (0.0423)</b>
	Path 5 (vs. Path 1)	0.003 (0.9691)	-	<b>0.935** (&lt;.0001)</b>	0.0513 (0.5459)
Traffic condition	Peak (vs. Off-Peak)	-	-	<b>-0.152** (0.005)</b>	-
Pavement markings	Yes (vs. No)	-	-0.1006 (0.058)	-	-
Extending auxiliary lanes	After toll plaza (vs. Base)	-	-	-	<b>0.202** (0.003)</b>
	Before toll plaza (vs. Base)	-	-	-	0.0046 (0.946)
Signage	Add DMS (vs. Base)	-0.0259 (0.7677)	-0.069 (0.311)	-	-
	Remove 3 <sup>rd</sup> sign (vs. Base)	<b>-0.169** (0.0112)</b>	-0.1099* (0.079)	-	-
Crash experience	Yes (vs. No)	-	-	-	<b>0.176** (0.0186)</b>
Age	18-25 (vs. 35-50)	<b>0.174** (0.0479)</b>	-	-	-
	25-35 (vs. 35-50)	0.141* (0.09)	-	-	-
	50-60 (vs. 35-50)	<b>0.291** (0.017)</b>	-	-	-
	60 or more (Vs. 35-50)	0.1223 (0.334)	-	-	-
Variance of random intercept ( $\theta_i$ )		<b>3.66** (0.0003)</b>			
Variance of residual ( $\varepsilon_{ij}$ )		<b>18.6** (&lt;0.0001)</b>			
Goodness of fit measures		-2LL=812.21, AIC= 816.21, BIC = 820.76, and R-squared=0.68			

\*\* Significant at 5% (bold values), \* significant at 10% level, and others are significant only at 10%.

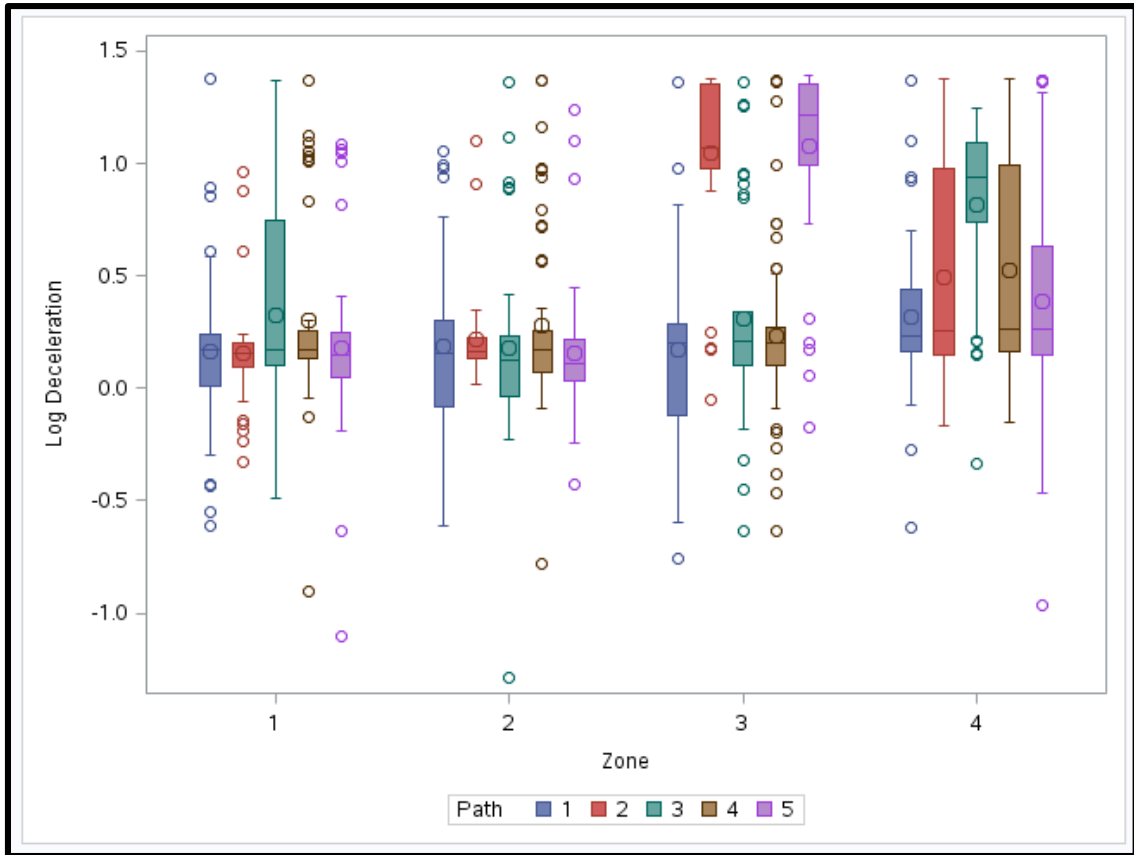

Figure 59. Relation between Log Deceleration at each Zone for each Path

### 7.1.7 Log Standard Deviation of Deceleration Model results

From the results of Table 27, when comparing the standard deviation of deceleration (braking action variation) between the different zones, it can be concluded that drivers tend to drive with a significantly higher braking action variation at the toll plaza zone than after the toll plaza zone. Also, the result shows that there is no significant difference between the braking action variation at the zones before the toll plaza (zone 1, and zone 2) and the toll plaza zone. Conclusions of scenario variables can be exhibited in several steps. First, from path decision-making point of view, participants drive with a significant higher braking action variation at path 2, path 3, path 4, and path 5 than the base condition (path 1), as shown in Figure 60. Second, arrow pavement markings have a significant effect on reducing the vehicles' deceleration variation before the toll plaza zone by 11%. Third, however, drivers who drive at the peak hour traffic condition tend to have a significant lower braking action variation than drivers who drive at the off-peak traffic condition at the toll plaza zone. Also, drivers after the toll plaza tend to have a considerable higher standard deviation of deceleration at congestion conditions. Fourth, extending auxiliary lanes after the toll plaza has a significant effect on increasing vehicles' braking action variation than the base condition after the toll plaza by 22% after the toll plaza zone. Fifth, the third case of signage which is removing the third overhead sign has an effect on reducing vehicles' braking action variation by 18%. Besides, the result clarifies the effect of the driver characteristic on the deceleration. First, the result indicates that female drivers tend to have a significantly lower variation of braking action by 15% in the first zone. Second, young drivers (18-25 years old) and old drivers (50 to 60 years old) drive with significantly higher deceleration variation than middle age drivers (35 to 50 years old) by 27% and 46%, respectively, at the first zone after the on-ramp (the merge area of the on-ramp and the mainline).

Table 27. Log Standard Deviation of Deceleration Model for Each Zone

Log Standard Deviation of Deceleration		Zone1	Zone2	Zone3	Zone4
		Estimate (p-value)	Estimate (p-value)	Estimate (p-value)	Estimate (p-value)
Intercept		<b>-0.246** (0.0248)</b>			
Zonal Intercept		-0.249* (0.0789)	-0.035 (0.7921)	-	<b>-0.303** (0.043)</b>
Path	Path 2 (vs. Path 1)	-	-	<b>0.878** (&lt;.0001)</b>	<b>0.233** (0.0166)</b>
	Path 3 (vs. Path 1)	-	-	0.155* (0.09)	0.182* (0.0541)
	Path 4 (vs. Path 1)	-	-	0.0851 (0.339)	<b>0.285** (0.002)</b>
	Path 5 (vs. Path 1)	-	-	<b>0.898** (&lt;.0001)</b>	0.155* (0.09)
Traffic condition	Peak (vs. Off-Peak)	-	-	<b>-0.125** (0.021)</b>	<b>0.116** (0.033)</b>
Pavement markings	Yes (vs. No)	-	<b>-0.108** (0.0438)</b>	-	-
Extending auxiliary lanes	After toll plaza (vs. Base)	<b>0.144** (0.037)</b>	-	-	<b>0.141** (0.038)</b>
	Before toll plaza (vs. Base)	0.115* (0.09)	-	-	-0.033 (0.628)
Signage	Add DMS (vs. Base)	-0.06527 (0.374)	-	-	-0.138* (0.09)
	Remove 3 <sup>rd</sup> sign (vs. Base)	<b>-0.169** (0.011)</b>	-	-	-0.032 (0.612)
Gender	Female (vs. Male)	<b>-0.144** (0.0236)</b>	-	-	-
Age	18-25 (vs. 35-50)	<b>0.238** (0.007)</b>	-	-	-
	25-35 (vs. 35-50)	0.171* (0.052)	-	-	-
	50-60 (vs. 35-50)	<b>0.378** (0.002)</b>	-	-	-
	60 or more (Vs. 35-50)	0.09814 (0.455)	-	-	-
Variance of random intercept ( $\theta_i$ )		<b>3.33** (0.00088)</b>			
Variance of residual ( $\epsilon_{ij}$ )		<b>18.63** (&lt;0.0001)</b>			
Goodness of fit measures		-2LL=826.15, AIC= 830.15, BIC = 834.7, and R-squared=0.44			

\*\* Significant at 5% (bold values), \* significant at 10% level, and others are significant only at 10%.

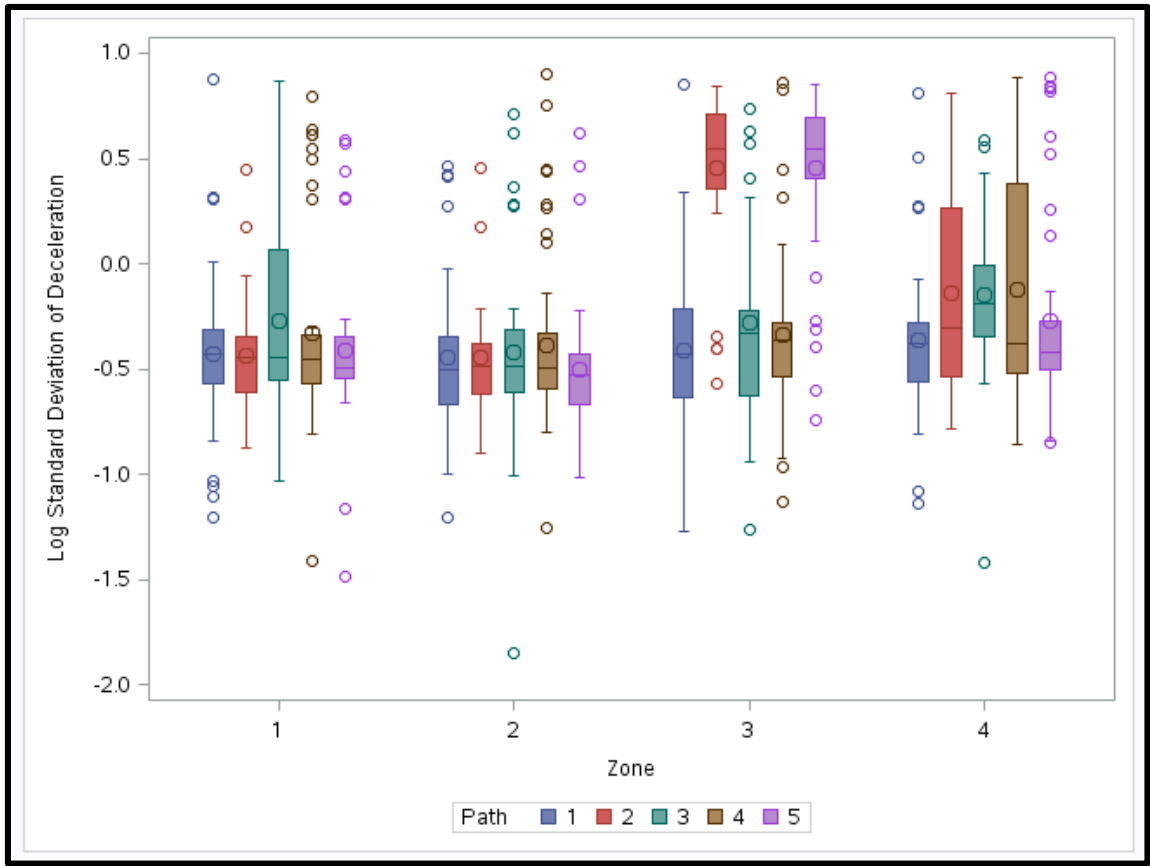

Figure 60. Relation between Log Standard Deviation of Deceleration at each Zone for each Path



## 7.2 Discussion

### 7.2.1 Scenario Variables

Five scenario factors were investigated including path, signage, pavement markings, extending auxiliary lanes, and traffic condition. First, drivers who come from the mainline through the open road tolling have a significantly higher speed and lower risk behavior (i.e., standard deviation of speed, standard deviation of lane position, acceleration noise, acceleration rate, deceleration rate, braking action variation) than those who used the tollbooth or those who came from the on-ramp or heading to the off-ramp. Vehicles from the on-ramp before the toll plaza (i.e., paths 4 and 5), as shown in Figure 32, have lower speed and higher risk behavior compared to Path 1 at all zones. It can be explained that vehicles from the on-ramp perform sudden lane change and unexpected weaving maneuvers before and after the toll plaza due to the speed variation. Additionally, vehicles from Path 3 which is driving through the ORT and heading to the off-ramp after the toll plaza have also a significantly lower speed and higher risk behavior. It can be clarified that vehicles which heading to the off-ramp decelerate to change lanes after the toll plaza. Furthermore, vehicles from Path 2 which comes from the mainline through the cash booths and merge again with the mainline, have lower speed at and after the toll plaza and riskier indicators at all zones due to the speed change and the sudden lane changing before and after the toll plaza. Second drivers who navigate in scenarios with the second case of signage, which is adding the DMS at the on-ramp, removing the third overhead sign, and relocating the second overhead sign as illustrated before in Figure 33, exhibited lower speed variation after the on-ramp than drivers who perform scenarios of the base condition with the second and the third overhead signs. Moreover, drivers who ran the scenarios with the third case of signage, which is removing the third overhead sign, manifested less risky driving behavior before and after the toll plaza than the base

condition. Third, arrow pavement markings have a considerable effect on reducing the standard deviation of speed, acceleration noise, standard deviation of lane deviation, and braking action variation before and after the toll plaza. From the results mentioned above, removing the third overhead sign before the toll plaza could reduce risky driving behavior because drivers may feel confusion and stress at toll plazas due to the excessive signs and arrow pavement markings that were installed before the toll plaza. Fourth, however, while extending auxiliary lanes before or after the toll plaza increases speed and reduces the lane deviation before and at the toll plaza zone, it can also increase acceleration noise and the braking action variation after the toll plaza. Finally, drivers during peak traffic conditions are more likely to have lower speed and lower risky driving behavior before the toll plaza.

#### 7.2.2 Driver Characteristics

The modeling results uncovered that younger drivers (18-25 years) and older drivers (older than 50 years) are more likely to have more dangerous behavior than middle age drivers (35-50 years) before and after the toll plaza. It can be explained that younger drivers usually drive at higher speeds and older drivers need more time for perception and reaction. Male drivers showed higher speed variation, acceleration noise, and braking action variation before the toll plaza. Moreover, driving behavior is influenced by many other factors such as education, income, driving frequency, ETC-tag use, and those with and without crash experience. Drivers with an attained education level higher than bachelor's degree drive with a lower speed compared to those with bachelor's degree or lower before, at, and after the toll plaza. Correspondingly, drivers with annual income (\$40,000 or higher) showed lower speed than drivers with lower income (less than \$40,000). Drivers with the lower driving frequency with less than five trips per week exhibits lower speed than those with more than three trips per day after the toll plaza. Moreover, drivers who are ETC-tag users are

more likely to drive at a higher speed than other drivers after the toll plaza because ETC-tag users are more familiar with the ETC system. Finally, drivers with crash history exhibit higher speed variation and higher deceleration rate than other drivers after the toll plaza.

## CHAPTER 8. CONCLUSIONS AND RECOMMENDATIONS

### 8.1 Conclusions

This research focused on the factors that influence risky driving behavior at toll plazas. The contribution of this study is evaluating driving behavior at plazas using a driving simulator and applying random effects to account for the data from same participants considering drivers' characteristics. Different scenarios have been assessed to test the effect of the potential critical factors on driver risk behavior. The Scenario variables include path decision making, signage, pavement markings, traffic condition, and extending auxiliary lanes. The literature suggested that proper signage and pavement markings should be applied at the toll plaza area to mitigate drivers' confusion and sudden lane changes (Abdelwahab and Abdel-Aty, 2002; McKinnon, 2013; Carroll, 2016).

The research in this study confirmed some of the results reached in previous studies. First, signage at the toll plaza area was found to affect the safety of toll plazas (Carroll, 2016; Brown et al., 2006; Mohamed et al., 2001; Valdes et al., 2016). Second, this research supports previous findings that pavement markings at toll plazas area have an influence on toll plaza safety (Brown et al., 2006; Mohamed et al., 2001; Valdes et al., 2016). Third, it confirmed that younger and older drivers are more likely to have less risky driving behavior than middle age drivers (Abdelwahab and Abdel-Aty, 2002; Abdel-Aty and Radwan, 2000). Fourth, for gender, it can be concluded from this research that male drivers showed higher risk behavior before the toll plaza, and this result is supported by Harré et al. (1996), and Evans (2004). Nevertheless, (Abdel-Aty and Radwan, 2000; Abdelwahab and Abdel-Aty, 2002) found that female drivers showed higher crash probability and more severe crashes than male drivers. Fifth, the research confirmed results by Lee and Abdel-Aty (2008) that drivers are more likely to drive with lower speed variation under congested conditions.

Finally, this study supports the conclusion from the literature that driving simulator experiment is a valid and efficient tool for further studies including exploring drivers' behavior during unfamiliar situations (e.g., managed lanes, driving diamond interchange (DDI), ramp metering, variable speed limit strategies, and variable message signs (VMS)).

## 8.2 Contributions and Recommendations

The results obtained from this study proposes some recommendations for improving toll plazas' safety on expressways. First, it is recommended to convert the hybrid toll plaza to the open-tolling system (e.g. managed lanes, and all-electronic toll collection system), since the results reveal that drivers at the ORT have less risky driving behavior than those who use the tollbooth. Second, appropriate signs and markings should be applied to guide the drivers safely and to mitigate speed variation and sudden lane change at toll plazas. Specifically, it is proposed to use DMS at the on-ramp to keep the vehicle in the right lane to reduce the lane change before the toll plaza. Also, it is suggested to relocate the third overhead sign which exists just before the toll plaza to before the on-ramp and keep the second overhead sign which is located after the on-ramp to reduce the abrupt lane changing before entering the toll plaza. Moreover, the existence of the arrow pavement markings before and after the toll plaza is important for reducing risky driving behavior. Thus, this type of pavement marking is strongly recommended to be included for expressway toll plazas in the next version of MUTCD. Finally, it is suggested to extend the auxiliary lanes before and after the toll plaza to reduce the sudden weaving maneuvers. It is expected that the findings from this study will be a good reference for expressway authorities and the Federal Highway Administration.

### 8.3 Further Research

The research findings from the simulation study present several recommendations for the improvement of the toll plaza. Recommendation for the future research includes not only applying more advanced statistics models and data mining techniques for the hybrid toll plaza study, but expanding the study to other types of toll plazas as well.

- The first recommendation is applying more advanced statistics models and data mining techniques including random effects discrete choice models for studying the factors that influence the aggressive behavior near the hybrid toll plaza.
- The second recommendation is building a new model in driving simulator for an all-electronic toll collection system and compare the driving behavior at the hybrid toll plaza experiment and the all-electronic toll collection to identify the impact of changing the toll plaza design.
- The third recommendation is building a new model using driving simulation for studying driving behavior at the managed lanes system and deciding sufficient length to access zones from on-ramps or to off-ramps and compare the driving behavior between the hybrid toll plaza and the managed lanes.

## **APPENDIX A: SIMULATOR QUESTIONNAIRE**

## **SIMULATOR QUESTIONNAIRE**

Before scenarios

1. Do you have a history of severe motion sickness or seizures?
  - a. Yes
  - b. No
  
2. How long have you had a Florida driver's license?
  - a. Less than 5 years
  - b. 5-10
  - c. 11-15
  - d. 16-20
  - e. 21+
  
3. How often do you use toll plazas?
  - a. One to two times per year
  - b. One to two times per month
  - c. One to two times per week
  - d. One to two times per day
  - e. Three or more times per day
  
4. What type of toll plaza are you most familiar with?
  - a. Traditional Mainline Toll Plaza
  - b. All-Electronic Toll Collection System
  - c. Hybrid Mainline Toll plaza
  
5. Do you own a E-PASS/E-Pass?
  - a. Yes
  - b. No
  
6. Have you driven in any fog conditions in the past year?
  - a. Yes
  - b. No





7. Are you familiar with dynamic message signs?
  - a. Yes
  - b. No
  
8. How old are you?
  - a. 18-24
  - b. 25-35
  - c. 36-50
  - d. 51-60
  - e. 60+
  
9. Did you learn how to drive in another state?
  - a. Yes
  - b. No

If yes, please explain:

10. How often do you typically drive?
  - a. 1-5 trips per week
  - b. 1-2 trips per day
  - c. 3-5 trips per day
  - d. 5+ trips per day

If never, please explain:

11. What is your highest level of education?
- a. Some high school
  - b. High school
  - c. Some College
  - d. Bachelor's Degree
  - e. Grad. School
12. What is your range of income?
- a. 0 – 10,000
  - b. 10,000 – 25,000
  - c. 25,000 – 40,000
  - d. 40,000 – 55,000
  - e. 55,000 – 70,000
  - f. 70,000+
13. Have you been in any vehicular accidents in the last 3 years?
- a. Yes
  - b. No

If so, what was the crash type (e.g. sideswipe, rear-end, head-on, etc.)? How many cars were involved? Where did the crash occur (e.g. intersection, highway, toll plaza, etc.)?

14. What vehicle do you normally drive?
- a. Sedan
  - b. Pickup Truck or Van
  - c. Motorcycle or Moped
  - d. Professional Vehicle (Large Truck or Taxi)
  - e. Other
15. Are you a professional driver / Does your job involve driving?
- a. Yes
  - b. No

## **SIMULATOR QUESTIONNAIRE**

Between scenarios

1. Do you feel sick or nauseous and need a rest?

a. Yes

b. No

2. Were you able to understand the signs?

a. Yes

b. No

Please, explain:

3. Did you have trouble navigating/understanding the course?

a. Yes

b. No

Please, explain:

### FOG SCENARIOS

1. How did you react to the change in visibility?

2. How much more difficult would you say it was driving in the fog compared to the clear condition? How difficult was it to see other vehicles or signs?

a. Extremely Difficult

b. Very Difficult

c. Somewhat Difficult

d. No Difference

3. Did the DMS sign make driving in the fog condition easier or less stressful or was it a distraction or unhelpful?
  - a. Helpful
  - b. Unhelpful
  
4. Was the DMS sign easy to read and understand?
  - a. Yes
  - b. No
  
5. How did you feel while driving in the fog condition?
  - a. Very Nervous
  - b. Slightly Nervous
  - c. Indifferent
  - d. Slightly Confident
  - e. Very Confident
  
6. How many DMS did you notice during your drive?
  - a. 0
  - b. 1
  - c. 2
  - d. 3
  
7. (If applicable) Did the beacons better prepare you for the fog condition?
  - a. Yes
  - b. No

#### TOLL PLAZA SCENARIOS

1. Did you have more trouble diverging into the separate toll plaza lanes and merging back on after the toll plaza?
  - a. Yes
  - b. No

Please, explain:

2. Do you think the signs were placed in proper locations and contained helpful information?
  - a. Yes
  - b. No

Please, explain:

3. Do you think you had a sufficient amount of time to decide which lane to get in and stay in to go through the appropriate toll collection area?
  - a. Yes
  - b. No

Please, explain:

## **SIMULATOR QUESTIONNAIRE**

After scenarios

1. How do you feel? Are you capable of leaving or need some time to rest?
2. Do you have any suggestions or feedback on how to improve the simulation or have any complaints in regards to the scenarios you ran?
3. Do you think the scenarios were logical and true to a real life situation?
4. What did you like and dislike about the simulation?
5. What did you think was the most beneficial towards your ability to navigate the courses?

## **APPENDIX B: FIGURES AND TABLES**

Figures and Tables for The Driving Behavior variables

Table of The Descriptive Statistics for each variable

<b>Variable</b>	<b>N</b>	<b>Mean</b>	<b>Standard deviation</b>	<b>Minimum</b>	<b>Maximum</b>
<b>Average Speed (mph)</b>	832	57.936	11.152	18.686	88.996
<b>Standard deviation of speed (mph)</b>	832	5.982	5.640	0.178	28.863
<b>Log standard deviation of speed (mph)</b>	832	0.623	0.363	-0.750	1.461
<b>Standard deviation of lane deviation (ft)</b>	832	1.430	0.733	0.079	3.293
<b>Log Standard deviation of lane deviation (ft)</b>	832	0.078	0.286	-1.101	0.518
<b>Acceleration (mph/s)</b>	822	3.011	3.208	0.05	14.976
<b>Log acceleration (mph/s)</b>	822	0.301	0.391	-1.303	1.176
<b>Acceleration noise (mph/s)</b>	822	0.720	0.797	0.011	4.227
<b>Log acceleration noise (mph/s)</b>	822	-0.341	0.416	-1.944	0.626
<b>Deceleration (mph/s)</b>	791	4.80	6.41	0.05	24.84
<b>Log deceleration (mph/s)</b>	791	0.38	0.49	-1.29	1.40
<b>Standard deviation of deceleration (mph/s)</b>	791	1.14	1.65	0.01	8.03
<b>Log standard deviation of deceleration (mph/s)</b>	791	-0.26	0.48	-1.85	0.90



Table of The Descriptive Statistics of Average Speed for each zone

Analysis Variable : allspeed allspeed						
zone	N Obs	N	Mean	Std Dev	Minimum	Maximum
1	214	208	57.6103903	7.2173538	26.7536893	76.8135955
2	214	208	60.4428307	7.6411852	31.5429621	82.0069209
3	214	208	52.1024982	15.8937137	18.6855694	87.8100200
4	214	208	61.5864219	9.0640938	37.1524095	88.9957403

Histogram of Average Speed Variable for all Zones

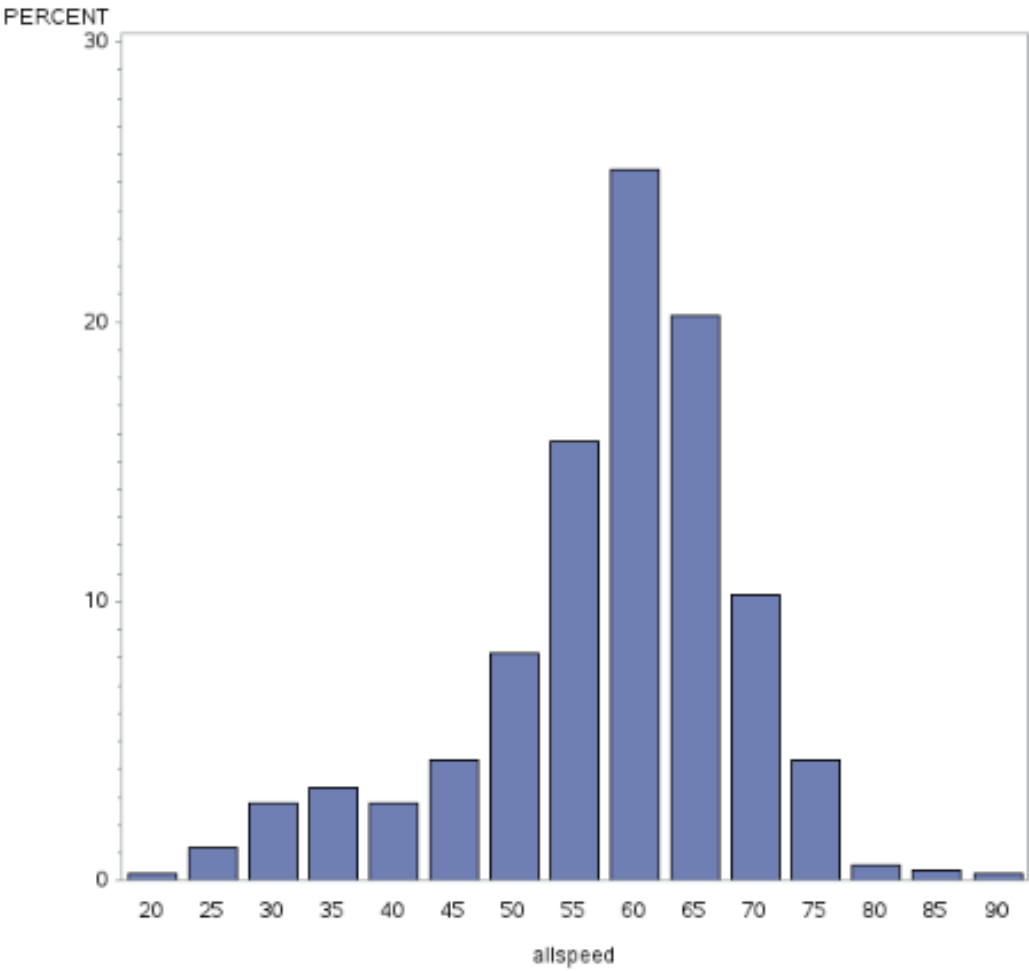

Histogram of Average Speed Variable for Zone 1

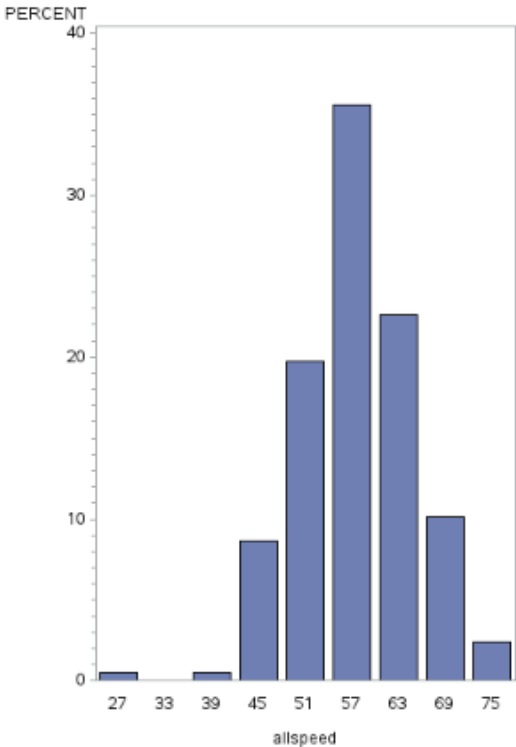

Histogram of Average Speed Variable for Zone 2

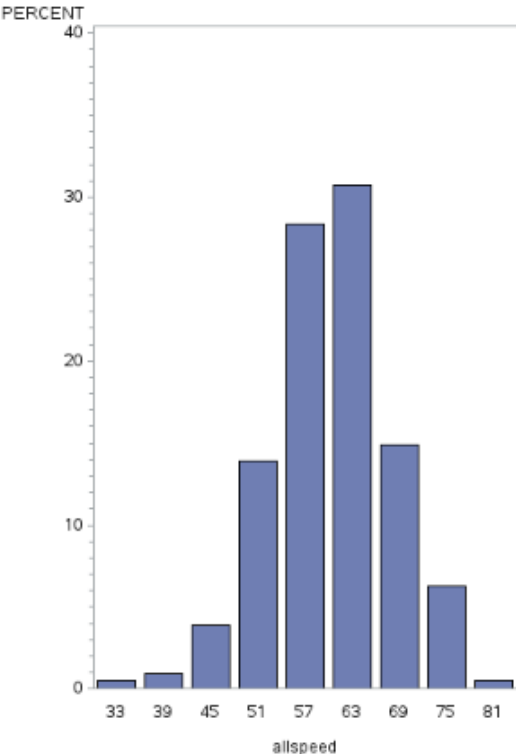

Histogram of Average Speed Variable for Zone 3

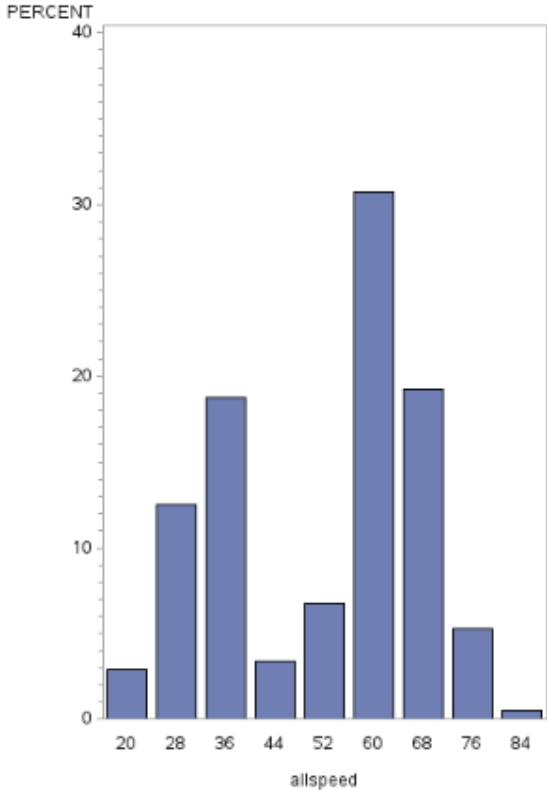

Histogram of Average Speed Variable for Zone 4

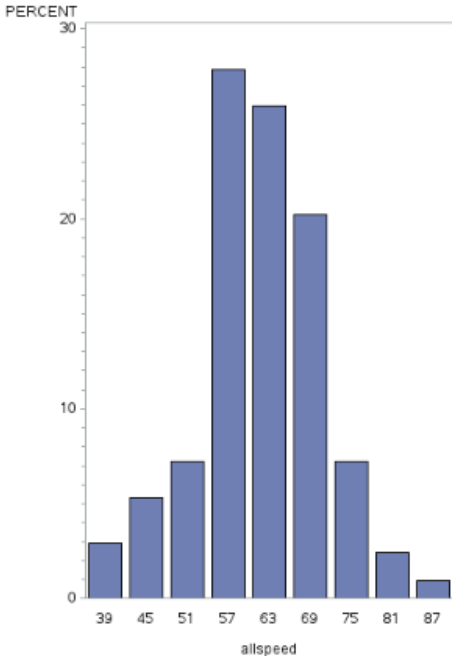
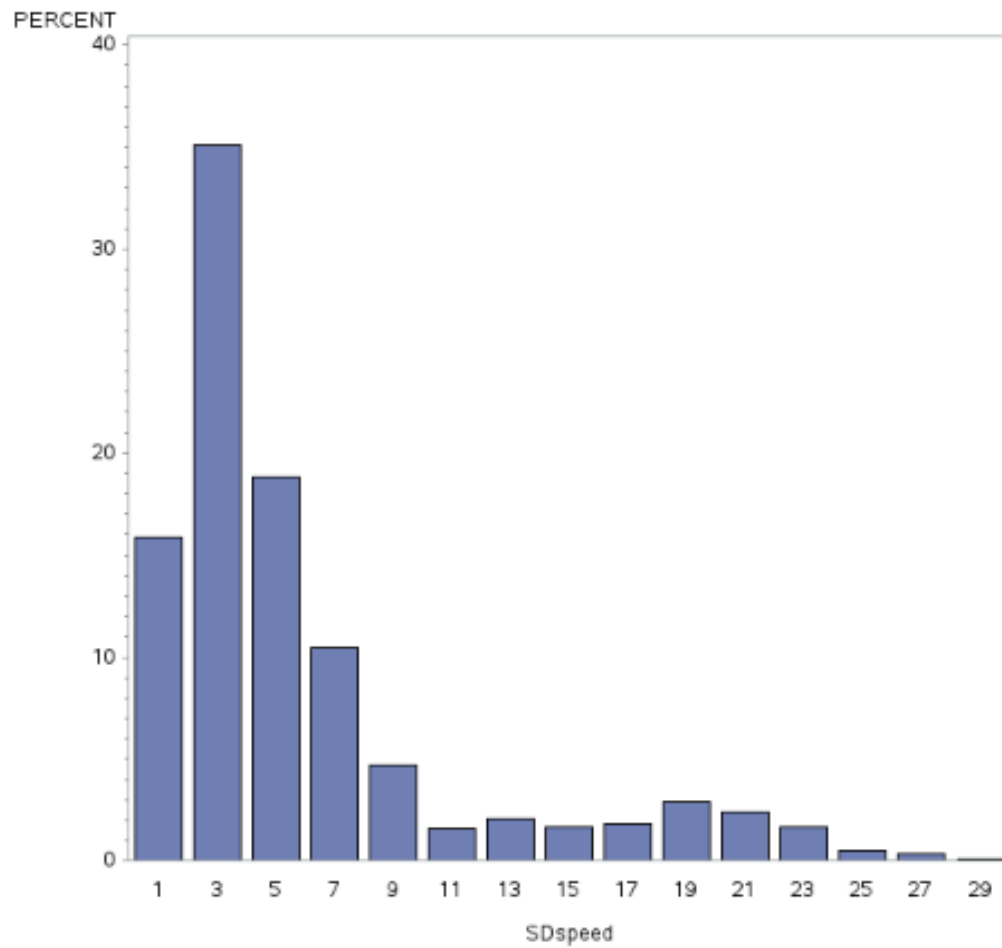

Table of The Descriptive Statistics of the Standard Deviation of Speed for each zone

Analysis Variable : SDspeed SDspeed						
zone	N Obs	N	Mean	Std Dev	Minimum	Maximum
1	214	208	4.8995148	3.1526476	0.4003543	27.7343909
2	214	208	3.8230600	2.4384820	0.4986203	18.6319654
3	214	208	10.2426521	8.4365295	0.4441943	28.8626341
4	214	208	4.9613026	3.9318115	0.1779417	18.2754180

Histogram of the Standard Deviation of Speed for all zones



Histogram of the Standard Deviation of Speed for zone 1

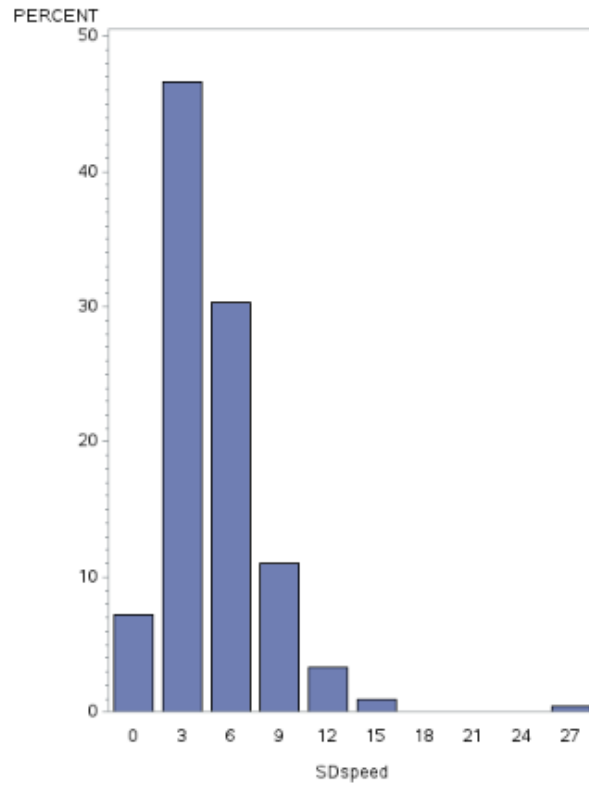

Histogram of the Standard Deviation of Speed for zone 2

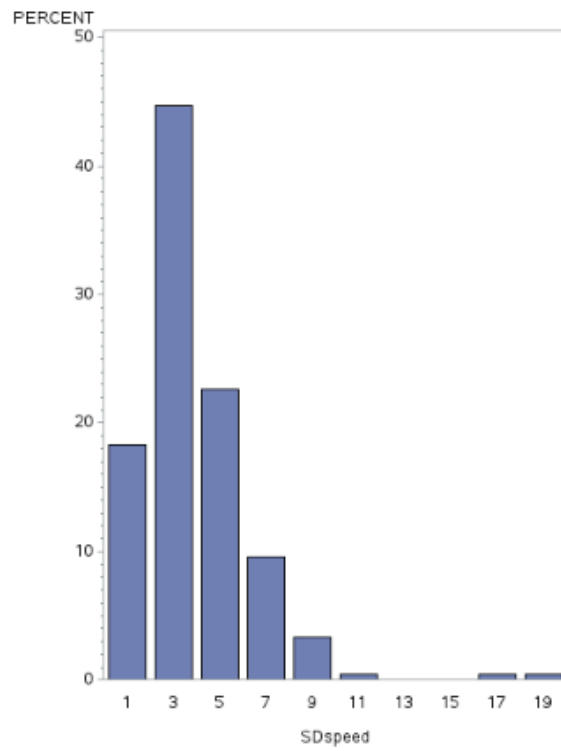

Histogram of the Standard Deviation of Speed for zone 3

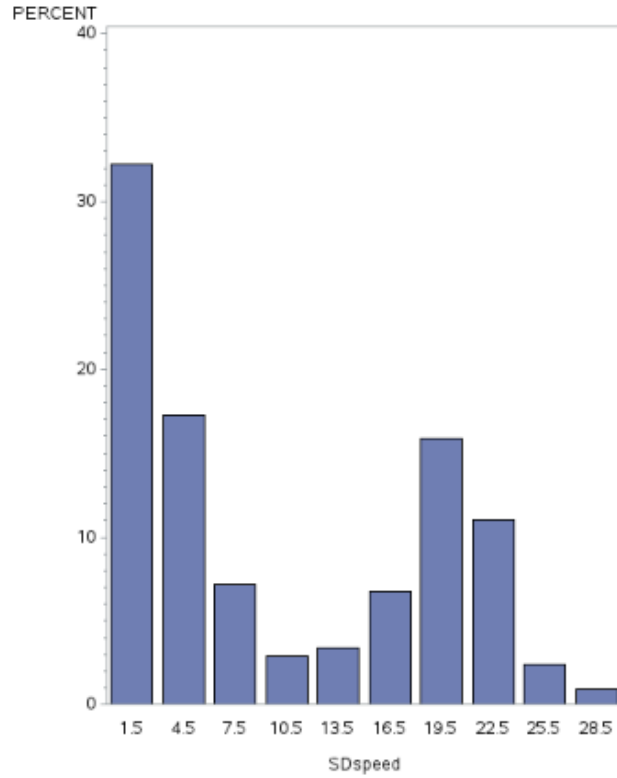

Histogram of the Standard Deviation of Speed for zone 4

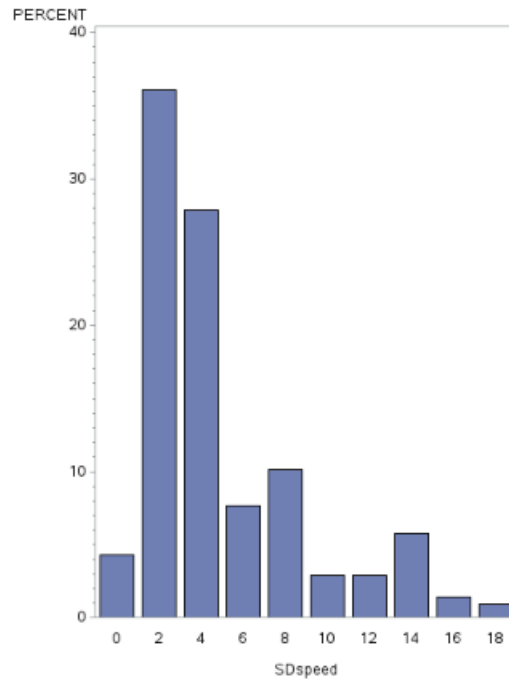
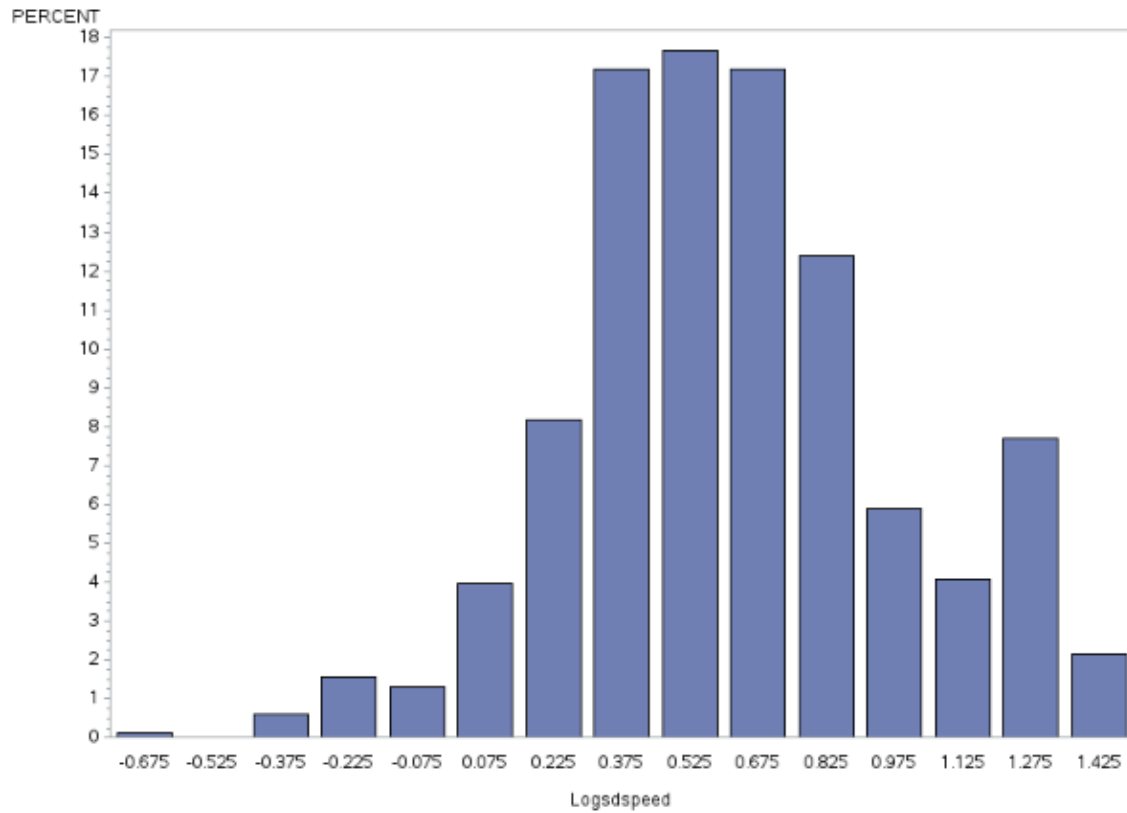

Table of The Descriptive Statistics of the Log Standard Deviation of Speed for each zone

Analysis Variable : Logspeed Logspeed						
zone	N Obs	N	Mean	Std Dev	Minimum	Maximum
1	214	208	0.6070081	0.2847765	-0.3975555	1.4430186
2	214	208	0.5069808	0.2627955	-0.3022300	1.2702587
3	214	208	0.8091847	0.4573880	-0.3524270	1.4603360
4	214	208	0.5699006	0.3421949	-0.7497223	1.2618673

Histogram of the Log Standard Deviation of Speed for all zones



Histogram of the Log Standard Deviation of Speed for zone 1

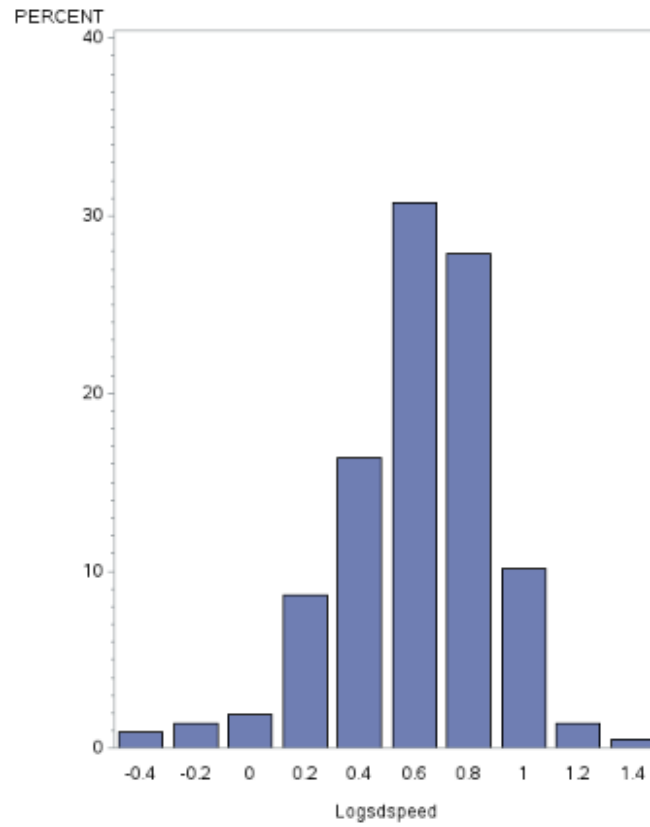

Histogram of the Log Standard Deviation of Speed for zone 2

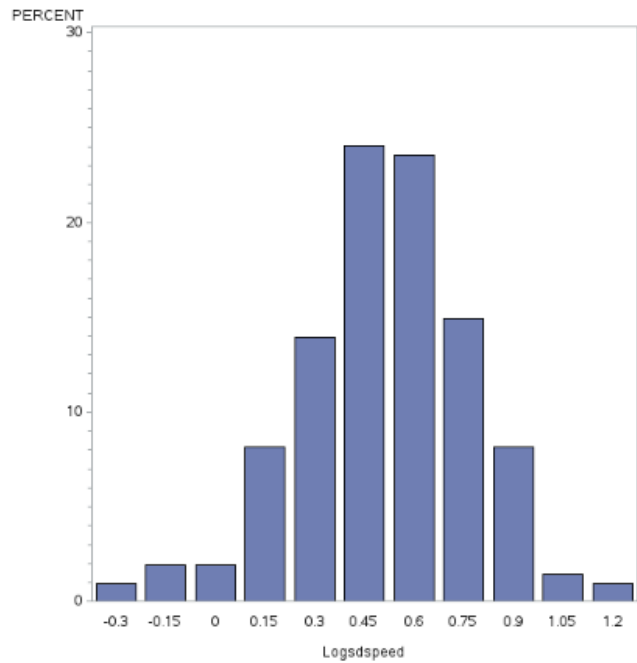



Histogram of the Log Standard Deviation of Speed for zone 3

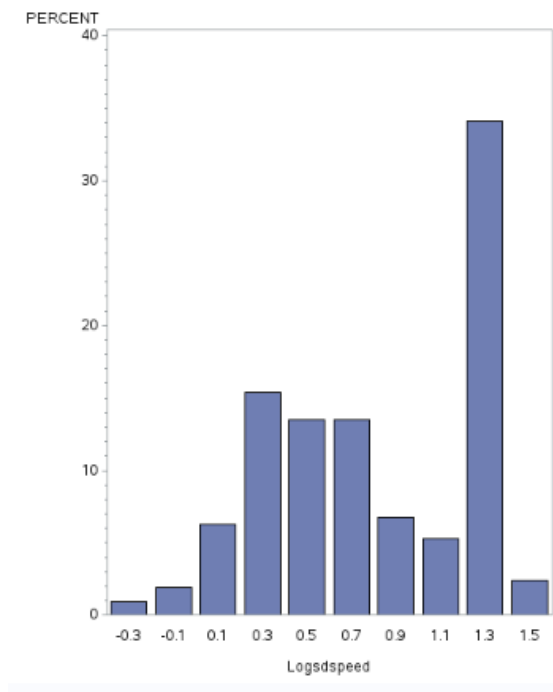

Histogram of the Log Standard Deviation of Speed for zone 4

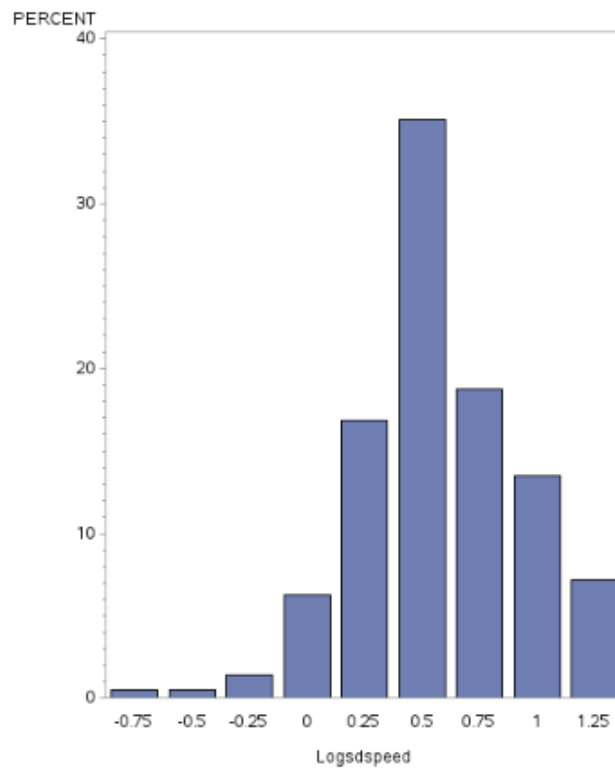
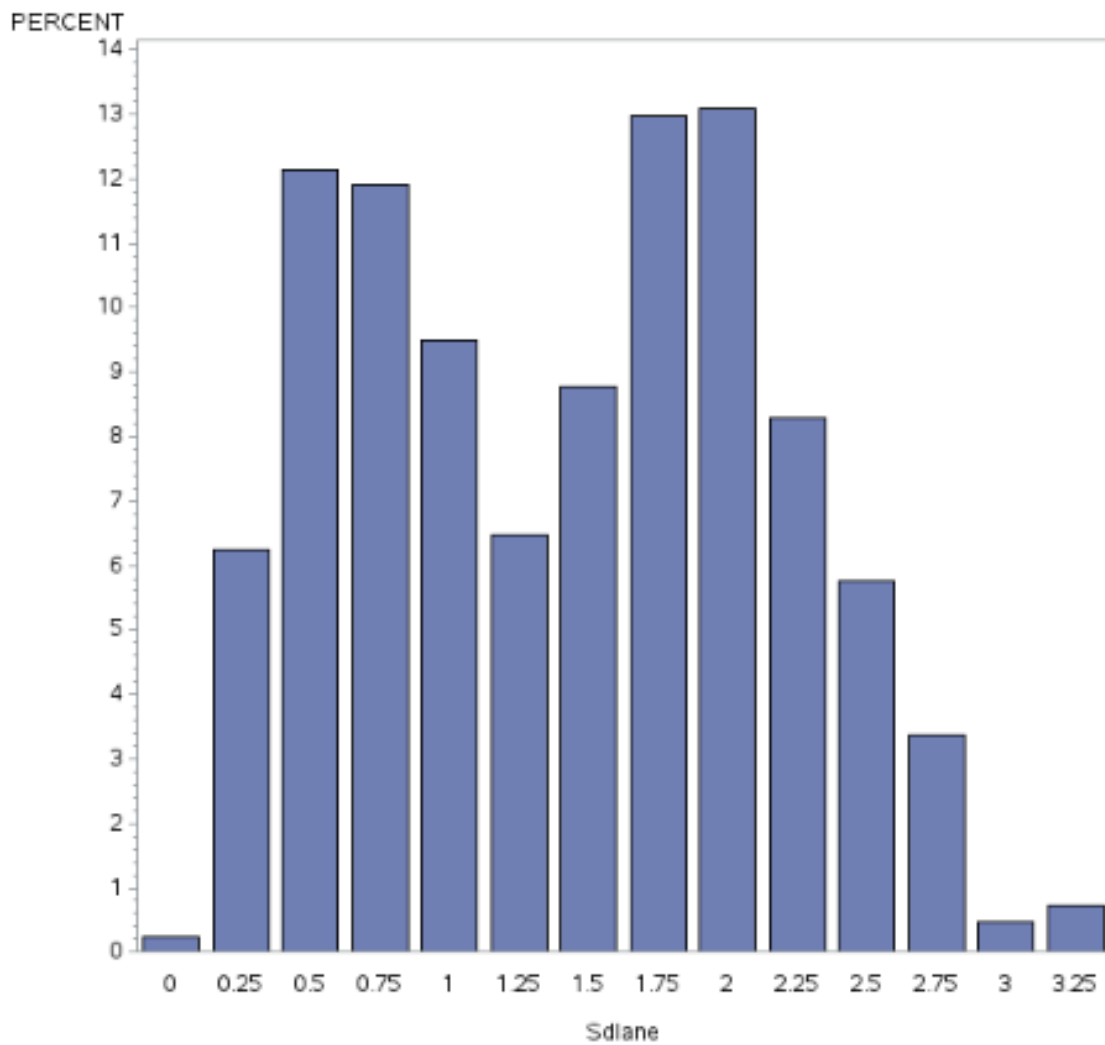

Table of Descriptive Statistics for the Standard deviation of lane deviation

Analysis Variable : Sdlane Sdlane						
zone	N Obs	N	Mean	Std Dev	Minimum	Maximum
1	214	208	1.3577080	0.8049401	0.0792281	3.2724273
2	214	208	1.2080658	0.6783674	0.1847898	2.7910125
3	214	208	1.6624136	0.6285472	0.3321529	3.2921966
4	214	208	1.4899745	0.7349463	0.0941983	3.1575991

Histogram of the Standard deviation of lane deviation for all zones



Histogram of the Standard deviation of lane deviation for zone 1

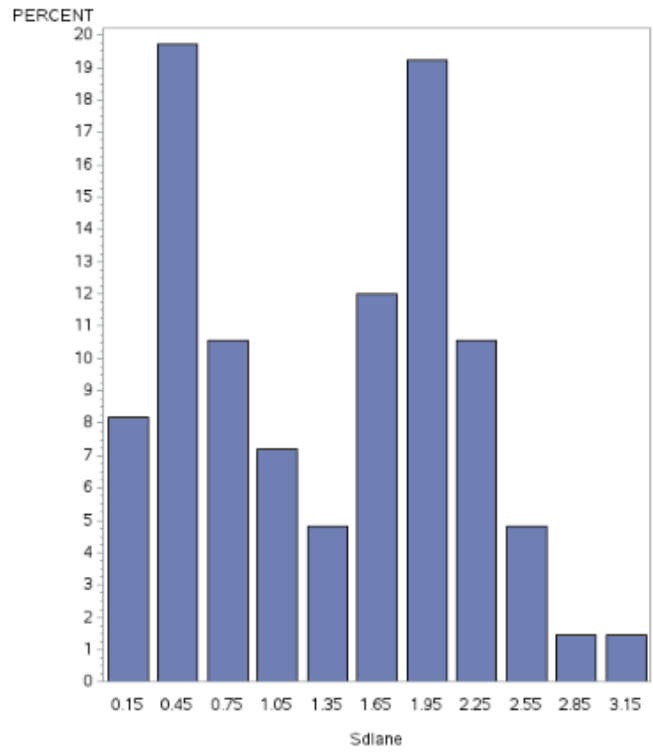

Histogram of the Standard deviation of lane deviation for zone 2

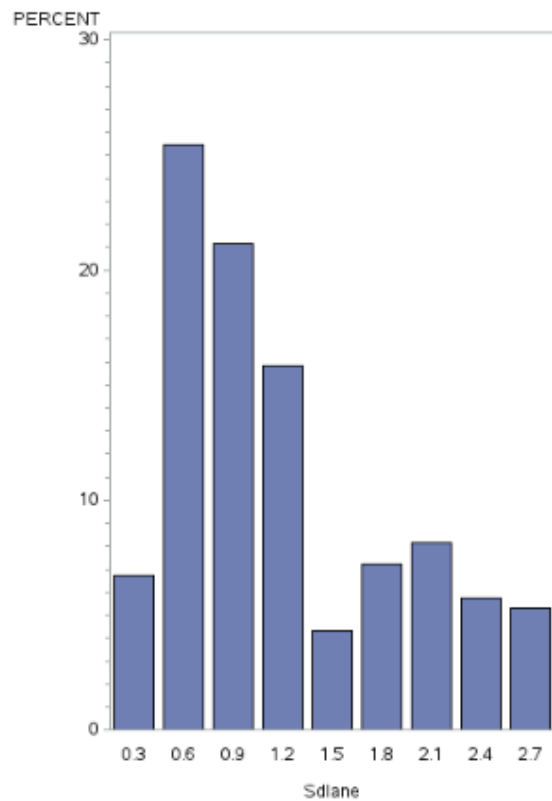

Histogram of the Standard deviation of lane deviation for zone 3

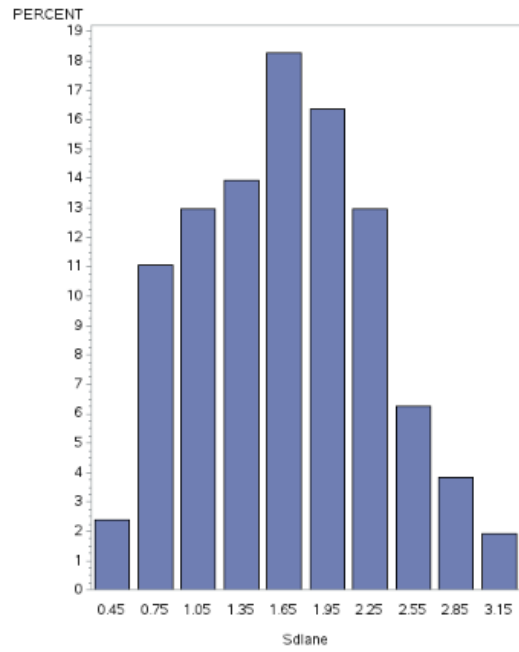

Histogram of the Standard deviation of lane deviation for zone 4

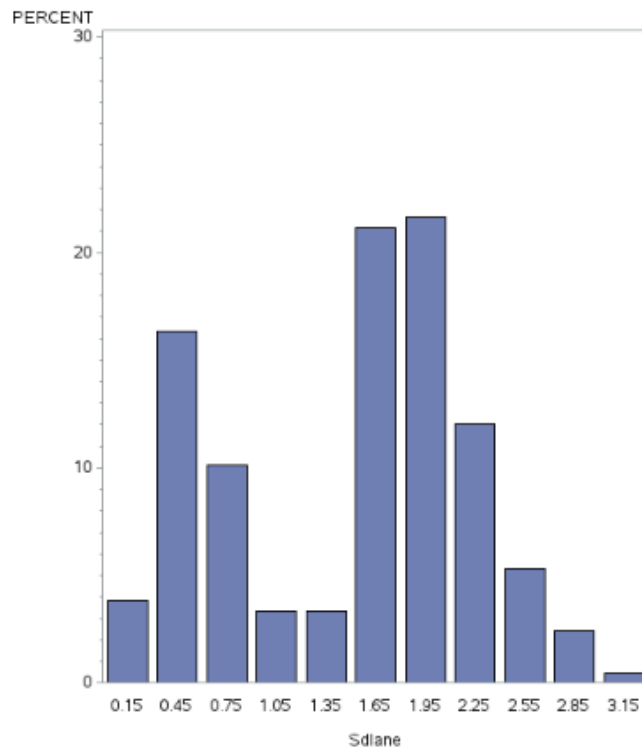
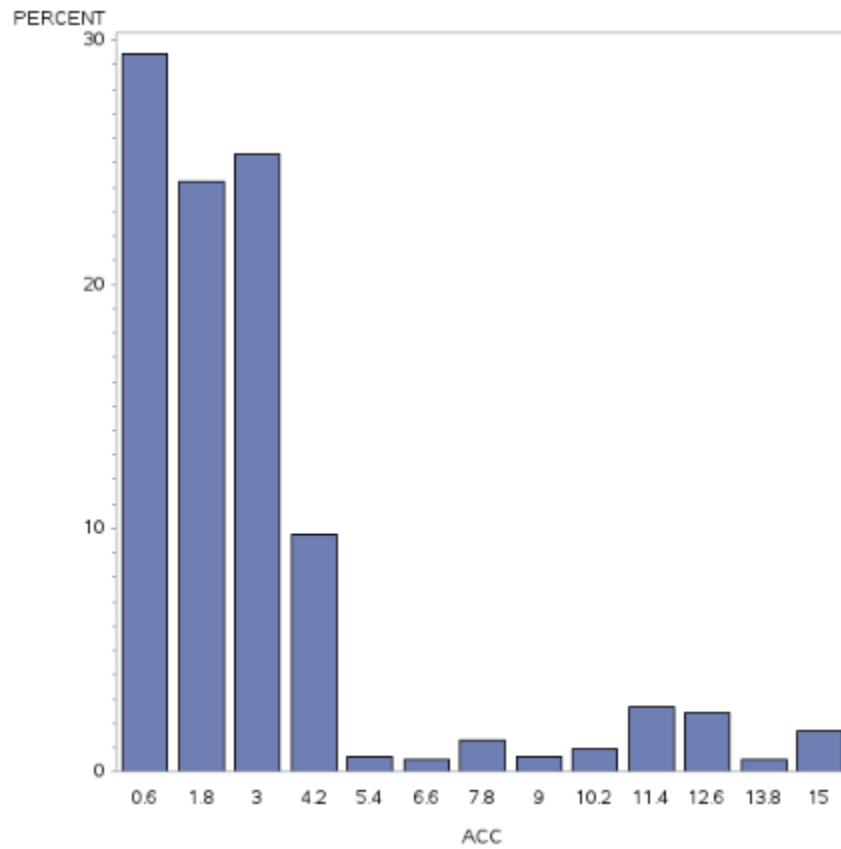

Table of Descriptive Statistics for the Acceleration

Analysis Variable : ACC ACC						
zone	N Obs	N	Mean	Std Dev	Minimum	Maximum
1	214	208	2.5639992	1.4172716	0.0876600	11.3898180
2	214	202	1.8339812	1.3083605	0.0496800	11.3092800
3	214	208	5.4003452	5.1271861	0.2467800	14.9756581
4	214	204	2.1928640	1.7223775	0.1966200	11.5780962

Histogram of the Acceleration for all zones



Histogram of the Acceleration for zone 1

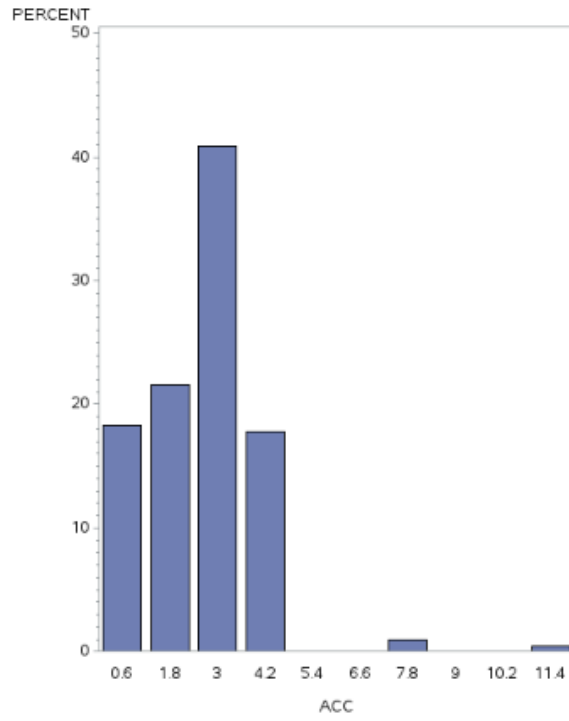

Histogram of the Acceleration for zone 2

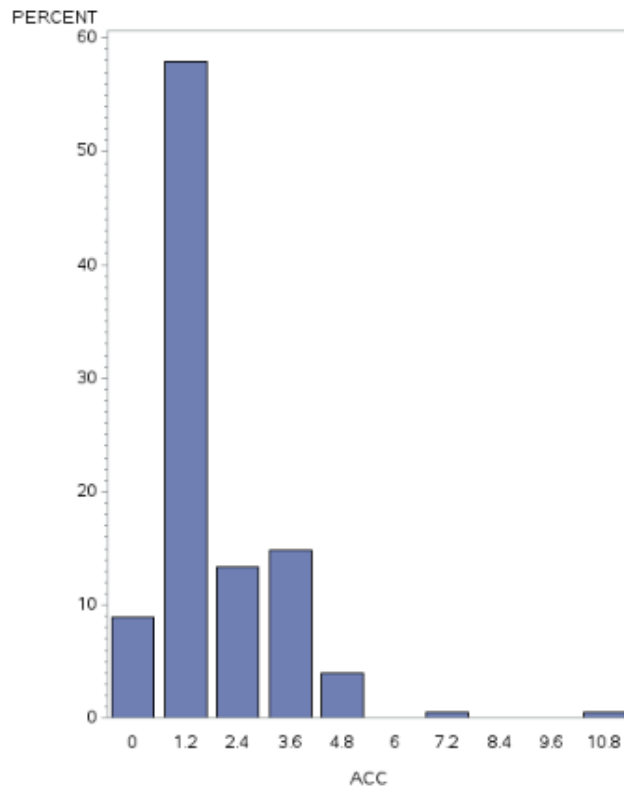

Histogram of the Acceleration for zone 3

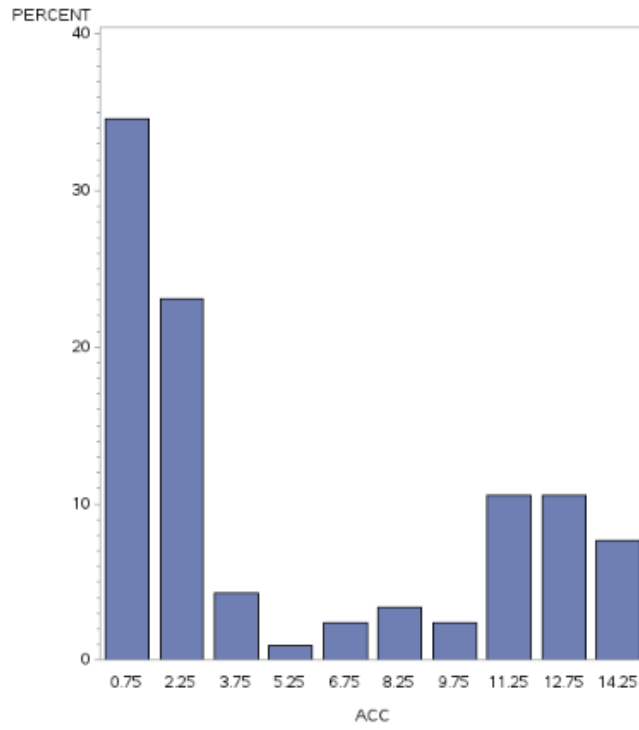

Histogram of the Acceleration for zone 4

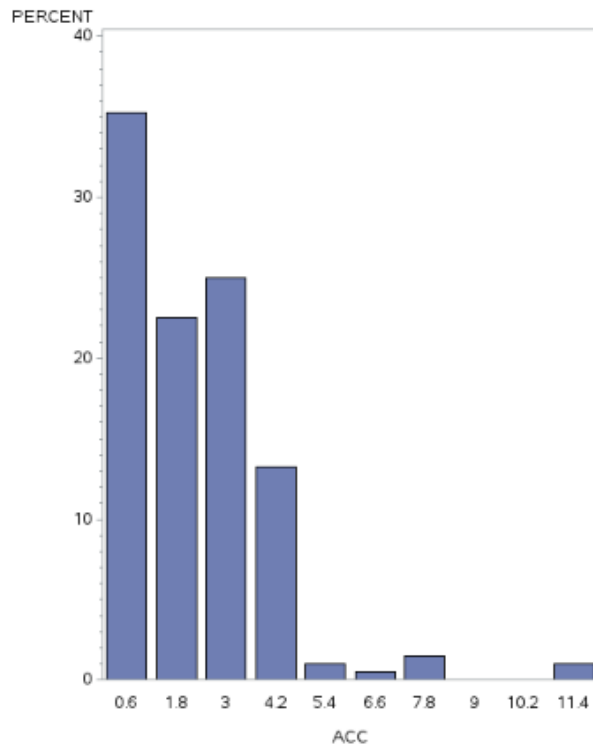
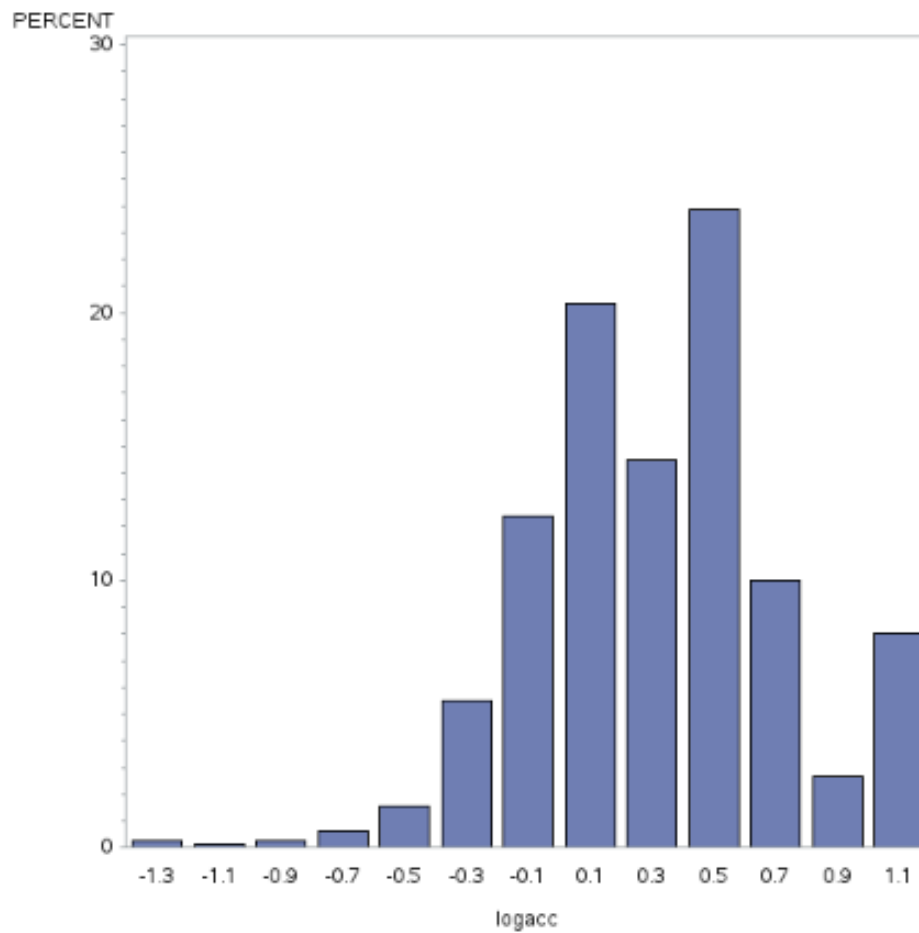

Table of Descriptive Statistics for the Log Acceleration

Analysis Variable : logacc logacc						
zone	N Obs	N	Mean	Std Dev	Minimum	Maximum
1	214	208	0.3303925	0.2954498	-1.0571985	1.0565168
2	214	202	0.1629634	0.3210467	-1.3038184	1.0534350
3	214	208	0.4783212	0.5039367	-0.6076900	1.1753859
4	214	204	0.2231616	0.3303428	-0.7063723	1.0636372

Histogram for the Log Acceleration for all zones





Histogram for the Log Acceleration for zone 1

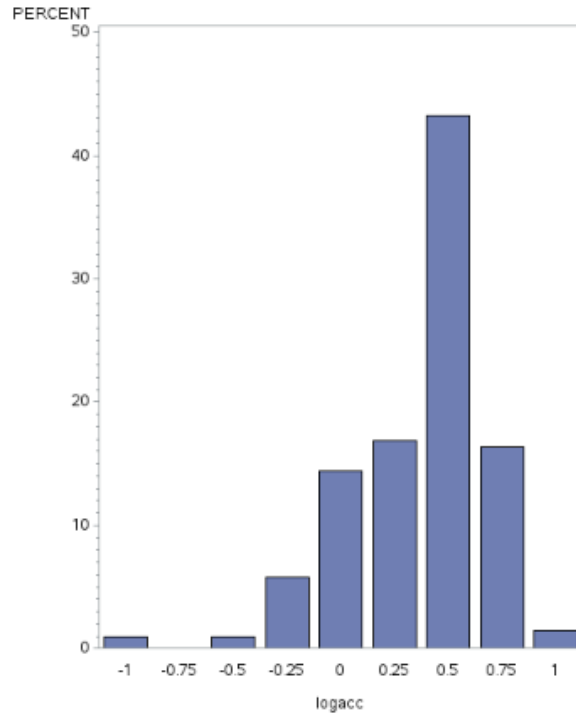

Histogram for the Log Acceleration for zone 2

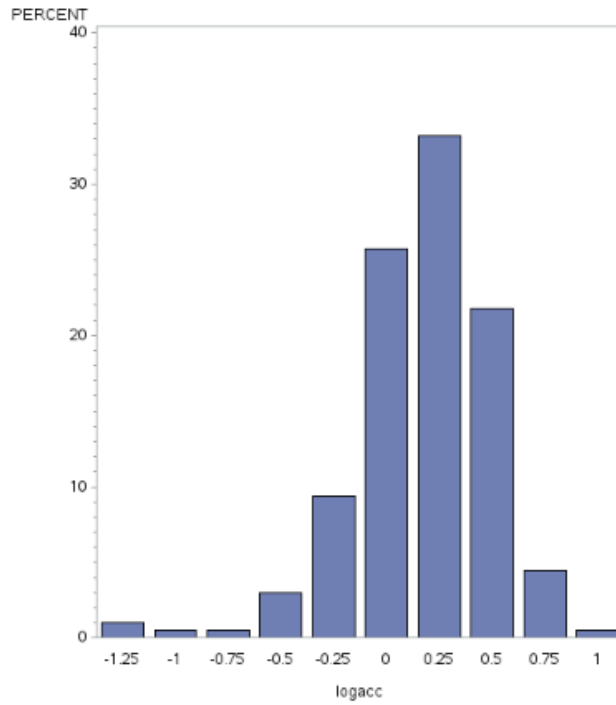

Histogram for the Log Acceleration for zone 3

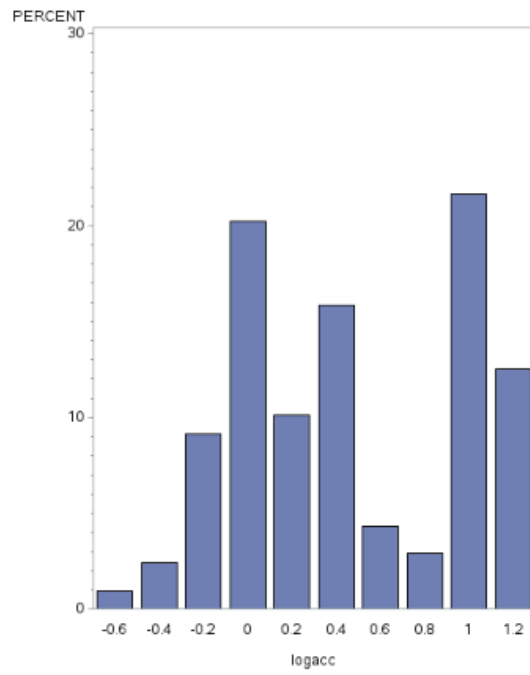

Histogram for the Log Acceleration for zone 4

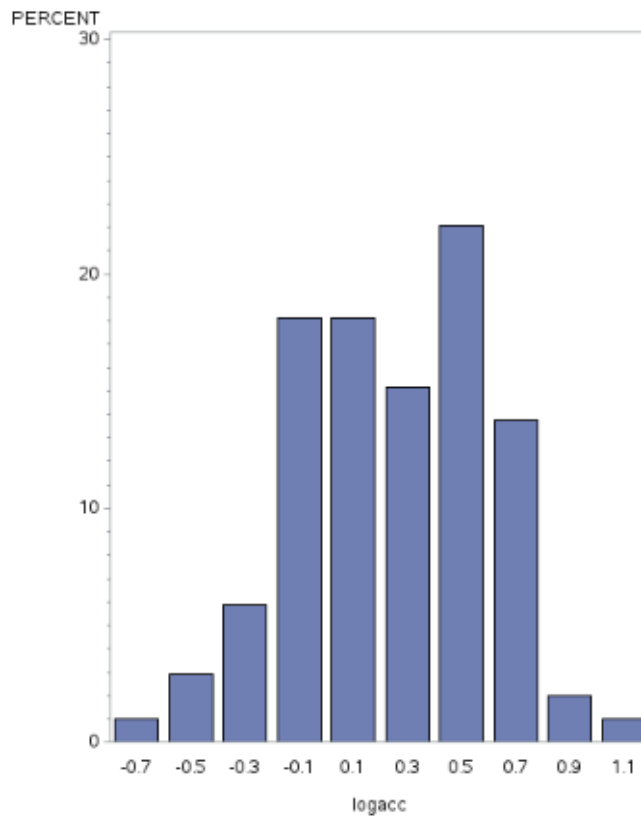

Descriptive Statistics for Acceleration Noise for each zone

Analysis Variable : SDACC SDACC						
zone	N Obs	N	Mean	Std Dev	Minimum	Maximum
1	214	208	0.6052550	0.3654035	0.0113768	2.6204957
2	214	202	0.4708209	0.3645893	0.0156771	2.9480131
3	214	208	1.2803969	1.2589479	0.0482618	4.1847252
4	214	204	0.5086681	0.4939284	0.0348029	4.2270791

Histogram for the Acceleration Noise for all zones

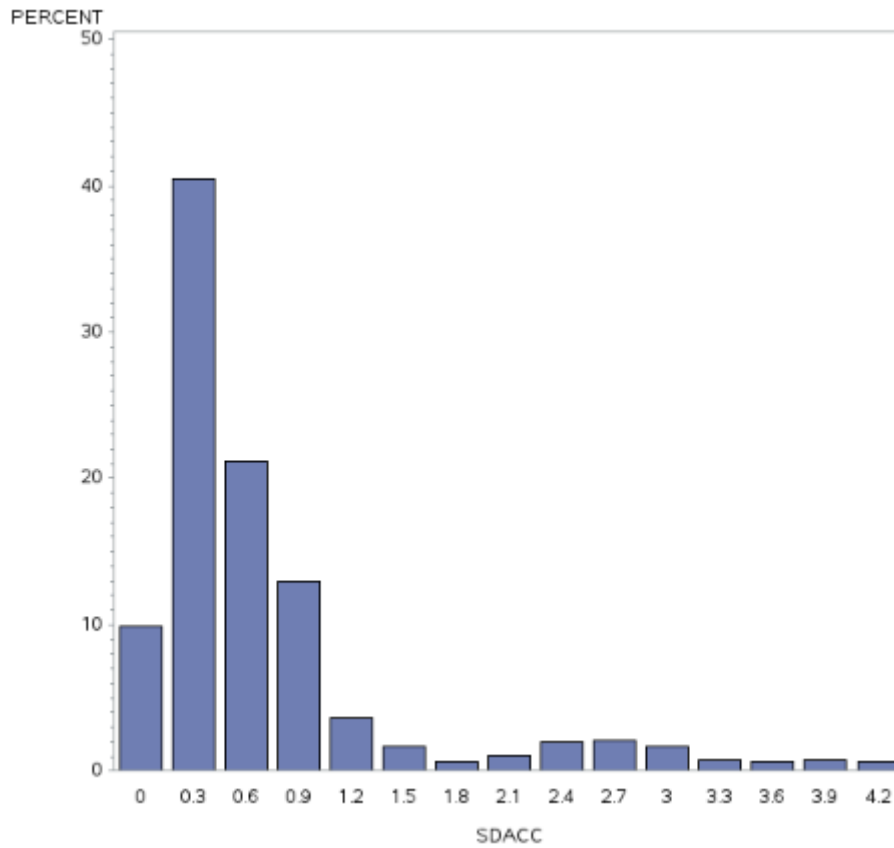

Histogram for the Acceleration Noise for zone 1

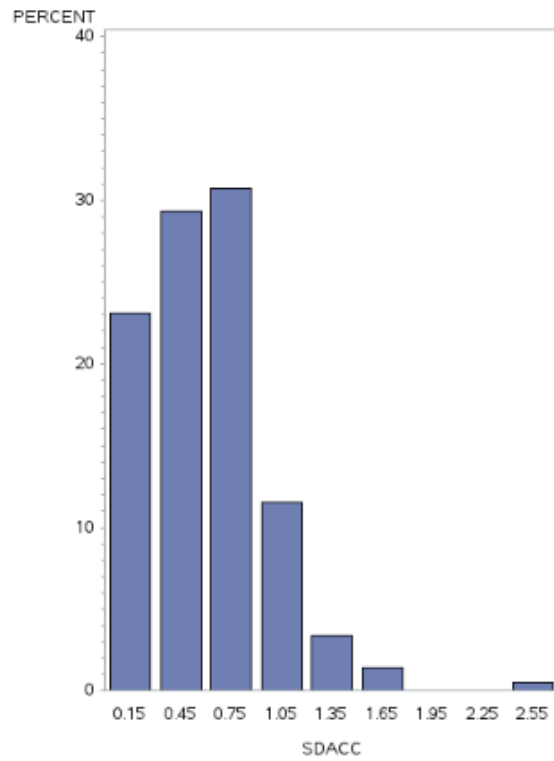

Histogram for the Acceleration Noise for zone 2

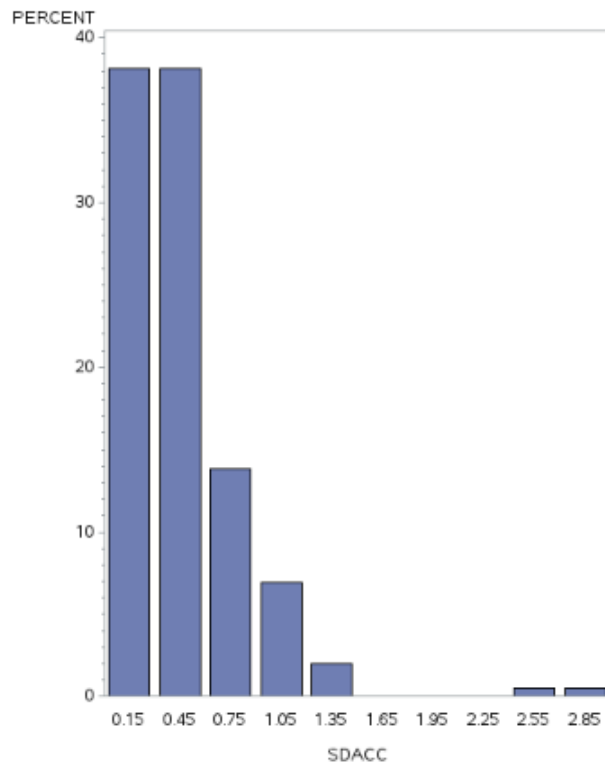

Histogram for the Acceleration Noise for zone 3

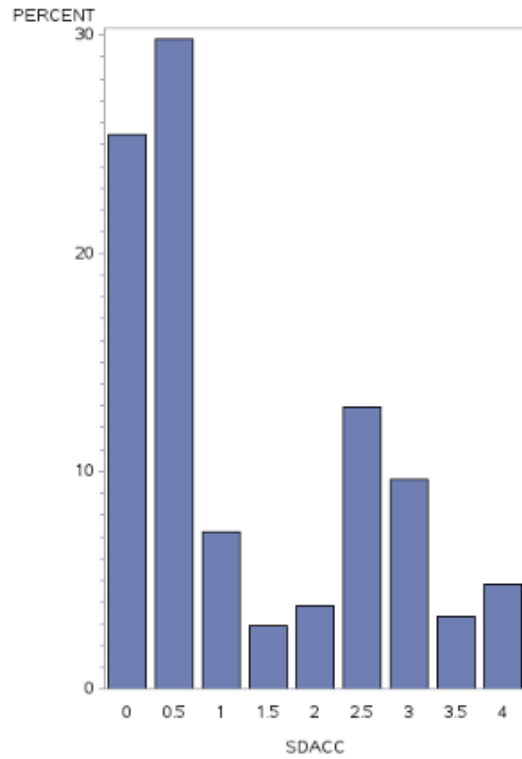

Histogram for the Acceleration Noise for zone 4

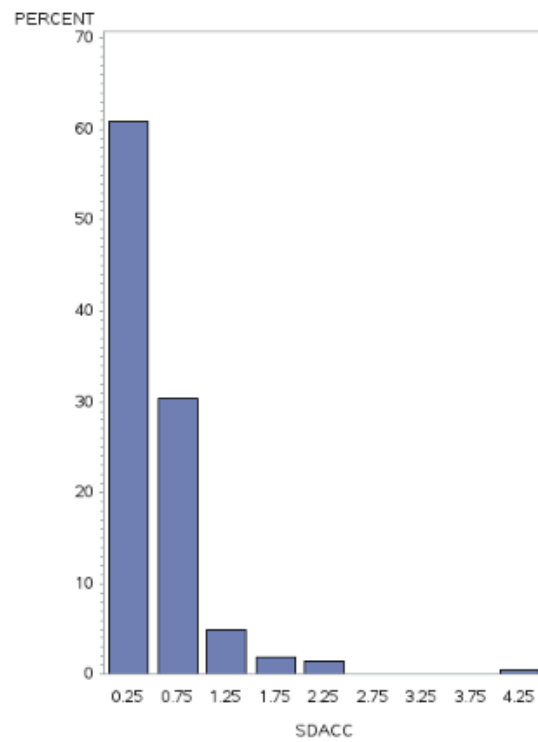

Descriptive Statistics of the Log acceleration noise for each zone

Analysis Variable : LogSDAcc LogSDAcc						
zone	N Obs	N	Mean	Std Dev	Minimum	Maximum
1	214	208	-0.3145715	0.3300631	-1.9439806	0.4183835
2	214	202	-0.4332654	0.3225021	-1.8047354	0.4695294
3	214	208	-0.1623873	0.5215174	-1.3163967	0.6216669
4	214	204	-0.4572638	0.3909668	-1.4583841	0.6260404

Histogram for the Log Acceleration Noise for all zones

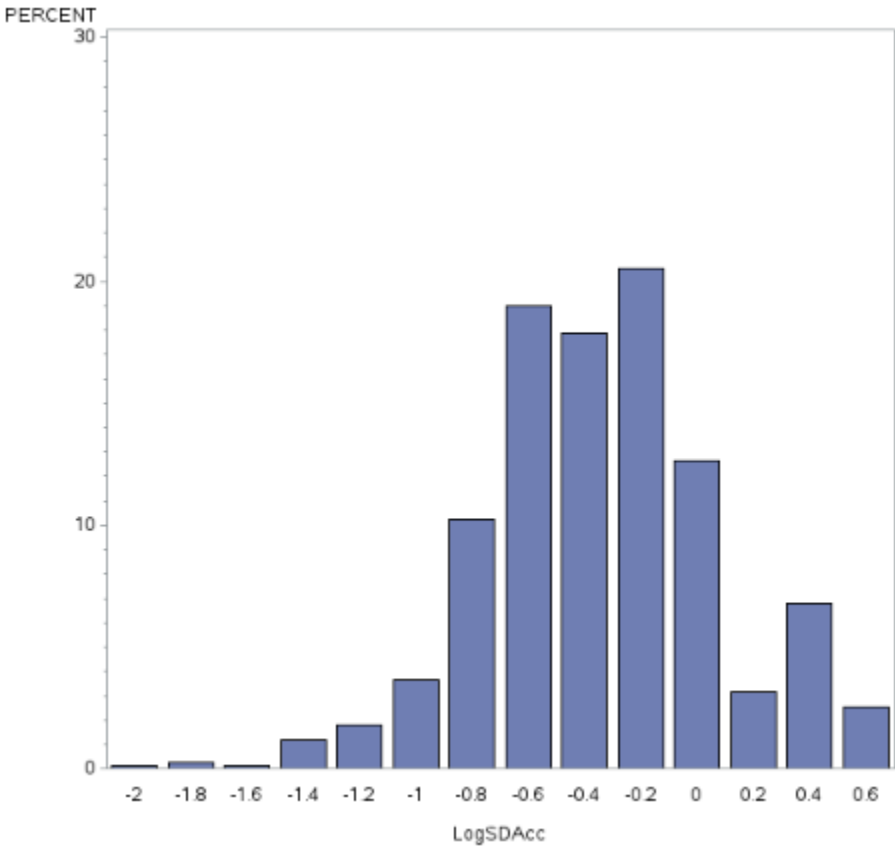

Histogram for the Log Acceleration Noise for zone1

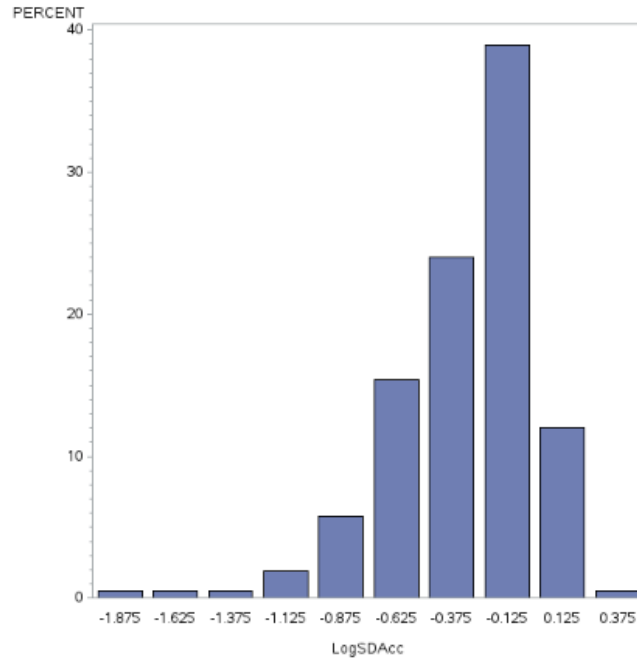

Histogram for the Log Acceleration Noise for zone 2

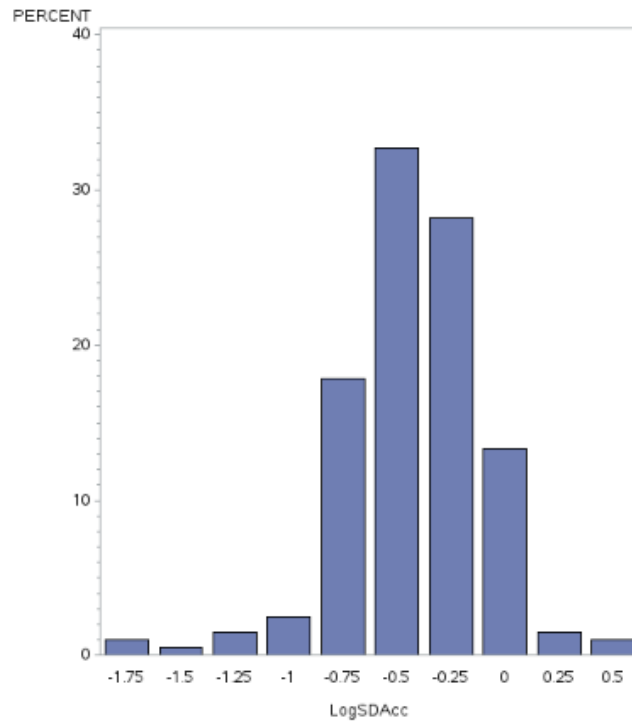

Histogram for the Log Acceleration Noise for zone 3

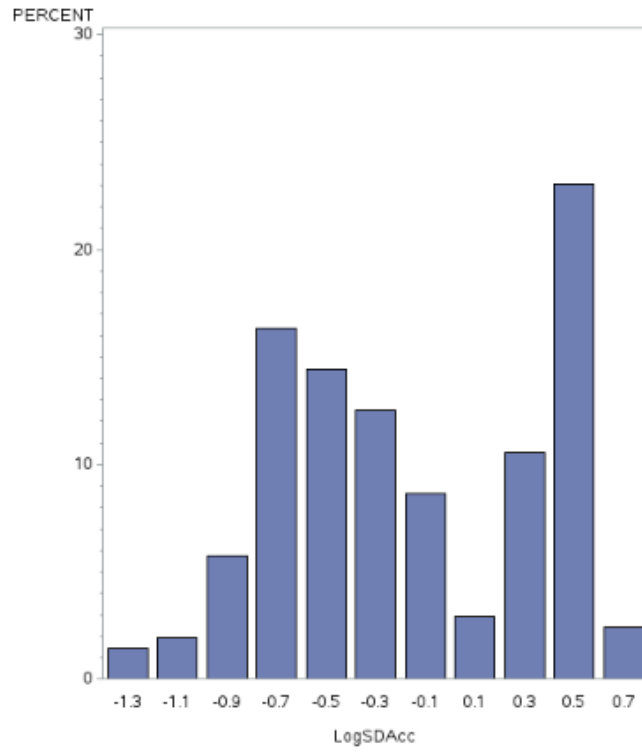

Histogram for the Log Acceleration Noise for zone 4

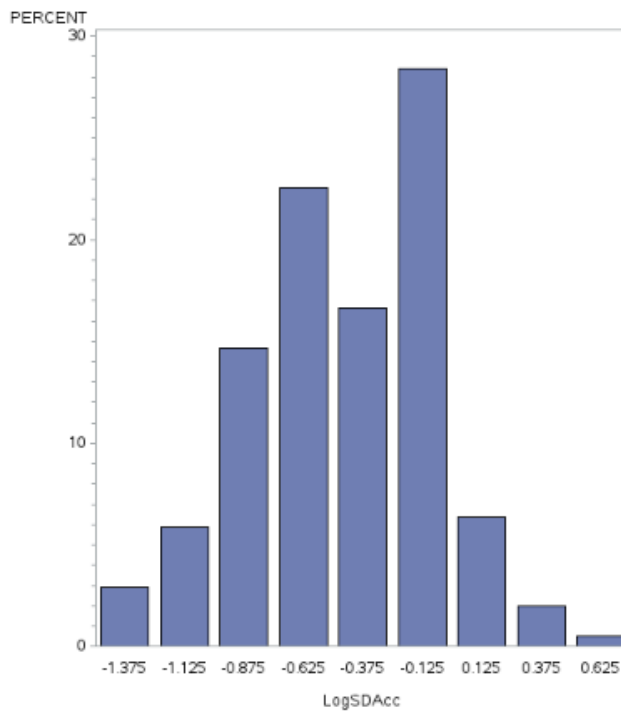



Descriptive Statistics of the Deceleration for each zone

Analysis Variable : DEC DEC						
zone	N Obs	N	Mean	Std Dev	Minimum	Maximum
1	214	187	-2.7879051	3.9363077	-23.8021200	-0.0794400
2	214	205	-2.5311249	3.7125081	-23.5254000	-0.0514800
3	214	199	-8.1073643	8.4179111	-24.8403000	-0.1753200
4	214	200	-5.7032661	6.5548537	-23.7423600	-0.1080600

Histogram for the Deceleration for all zones

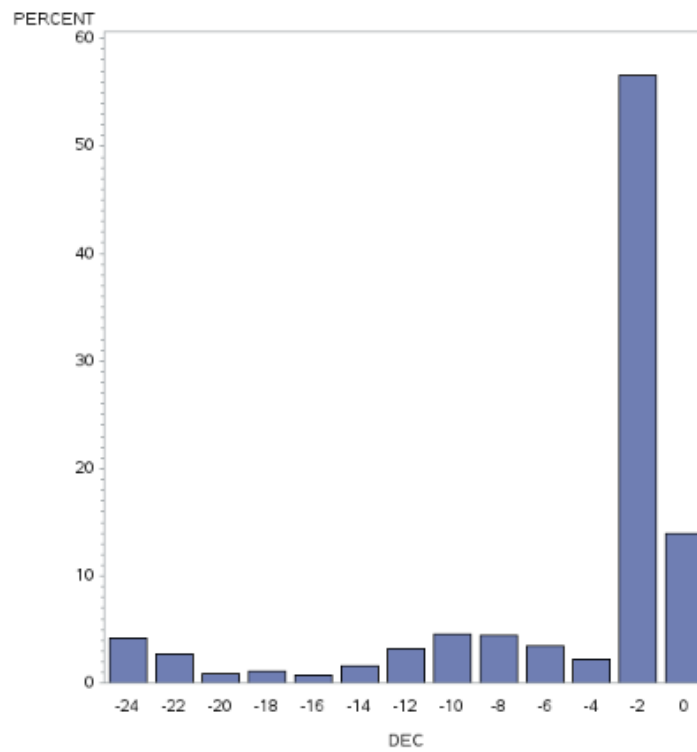

Histogram for the Deceleration for zone 1

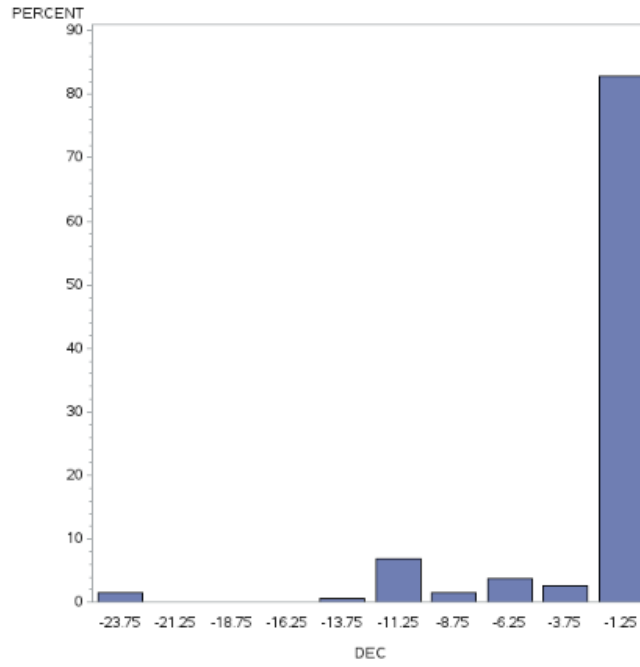

Histogram for the Deceleration for zone 2

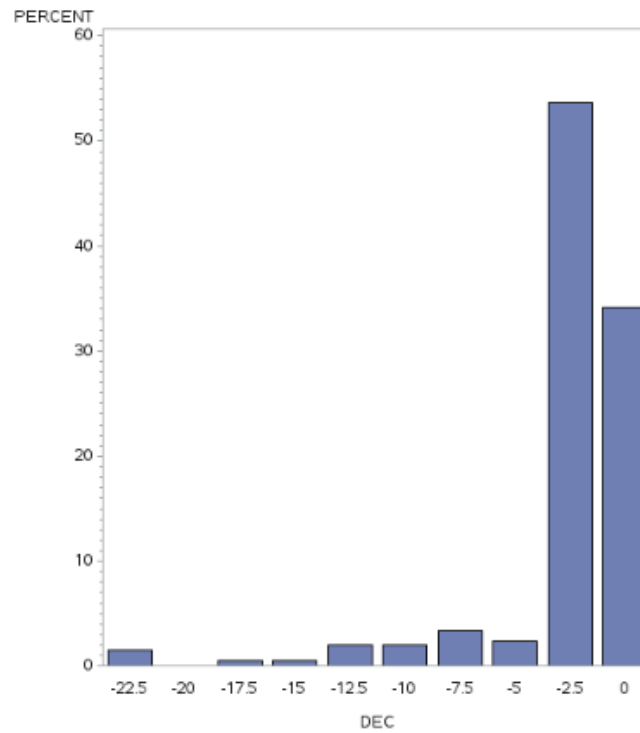

Histogram for the Deceleration for zone 3

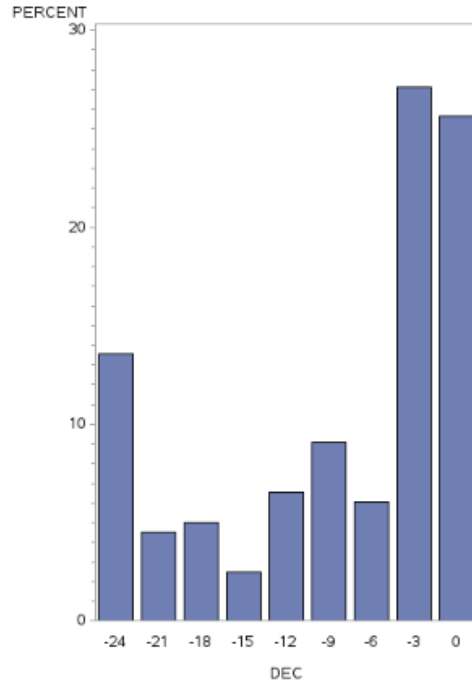

Histogram for the Deceleration for zone 4

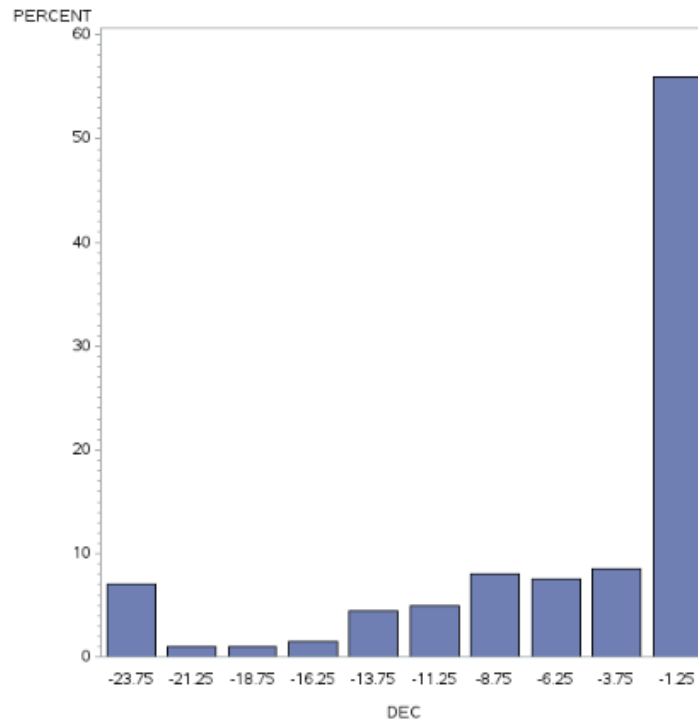

Descriptive Statistics of the Log Deceleration for each zone

Analysis Variable : logdec logdec						
zone	N Obs	N	Mean	Std Dev	Minimum	Maximum
1	214	187	0.2285263	0.3898894	-1.0999608	1.3766156
2	214	205	0.2056027	0.3588148	-1.2883615	1.3715370
3	214	199	0.5896950	0.5772109	-0.7561685	1.3951568
4	214	200	0.5003804	0.4709732	-0.9663350	1.3755239

Histogram for the Log Deceleration for all zones

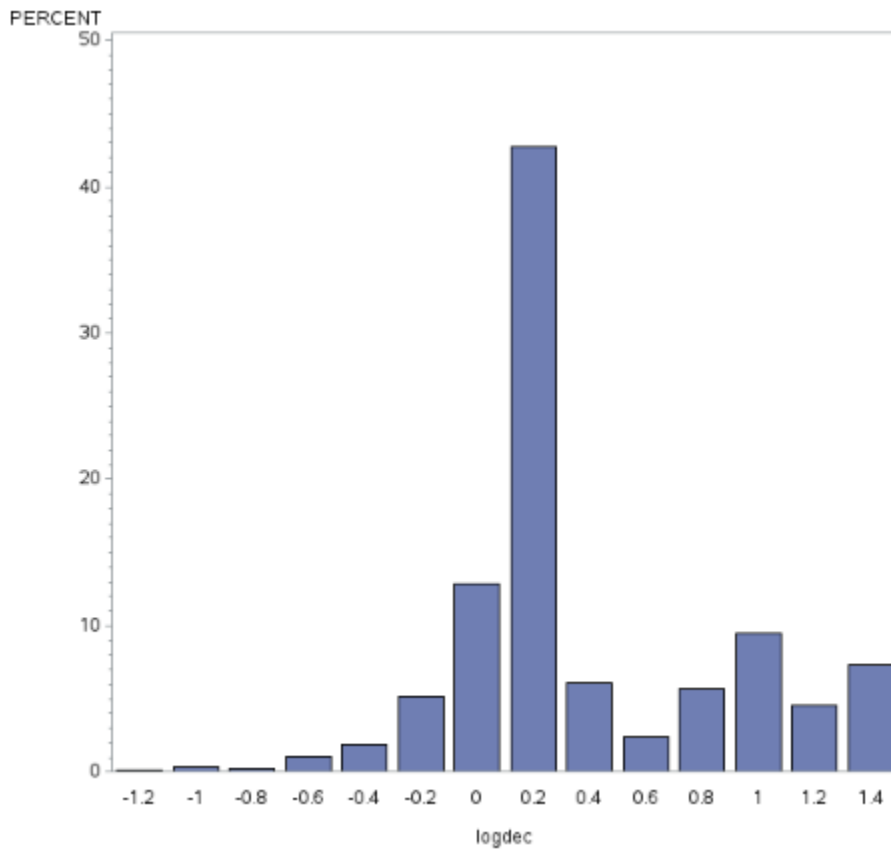

Histogram of the Log Deceleration for zone 1

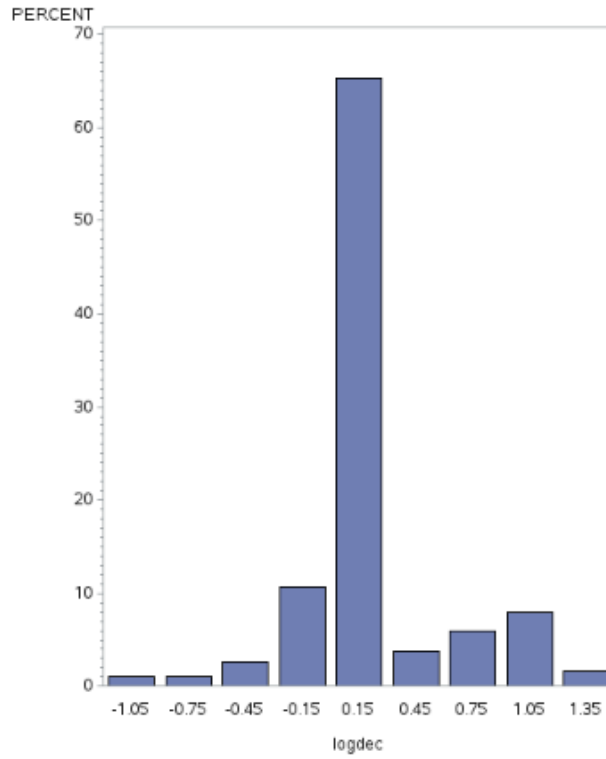

Histogram of the Log Deceleration for zone 2

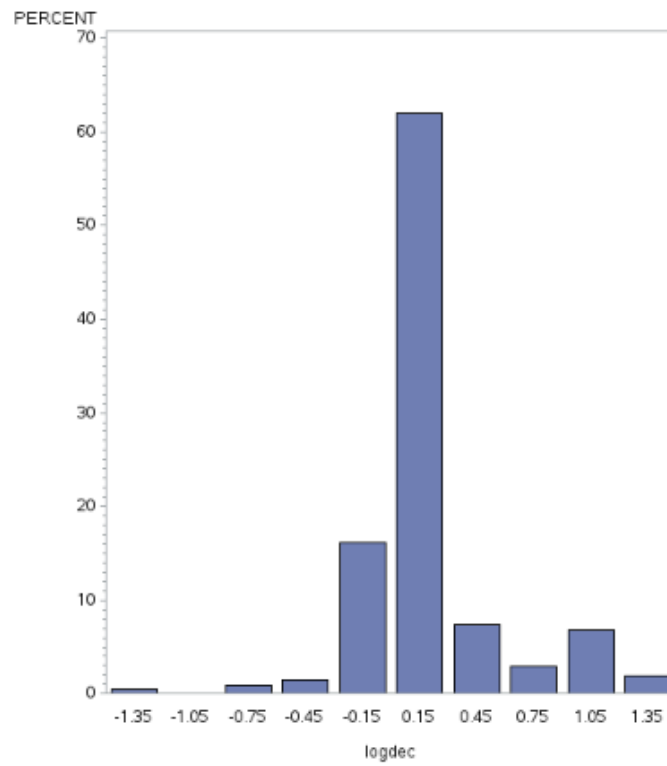

Histogram of the Log Deceleration for zone 3

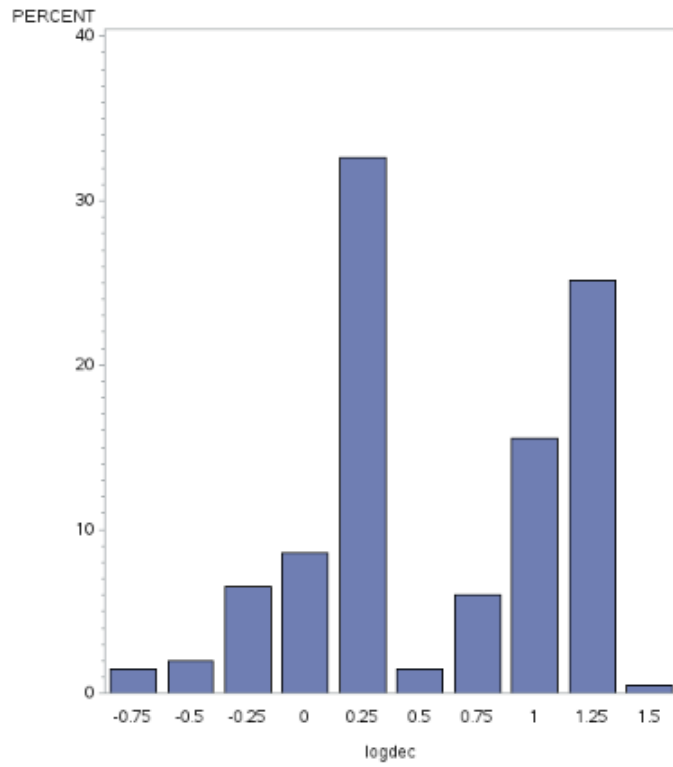

Histogram of the Log Deceleration for zone 4

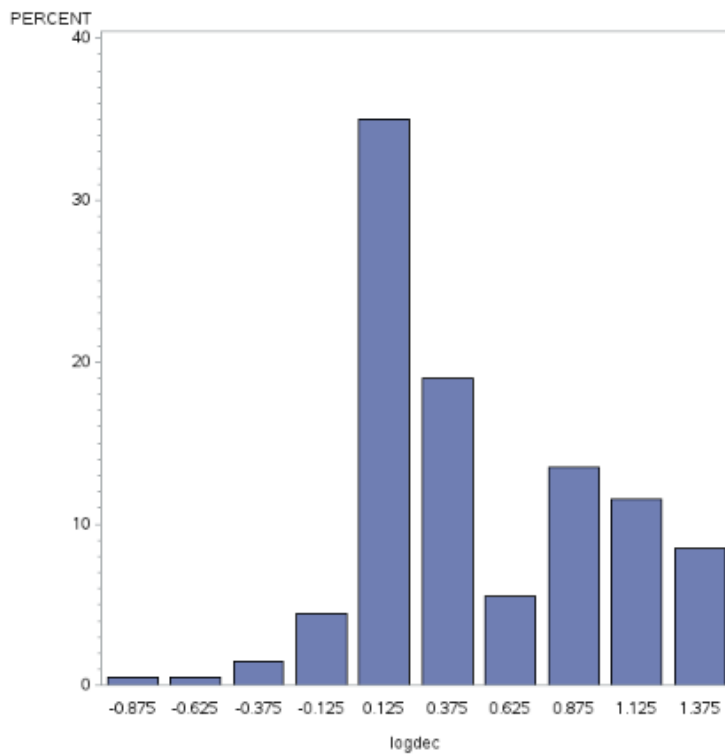

Descriptive Statistics of the Standard Deviation of Deceleration for each zone

Analysis Variable : SDDEC SDDEC						
zone	N Obs	N	Mean	Std Dev	Minimum	Maximum
1	214	187	0.7403602	1.1828219	0.0326077	7.4796403
2	214	205	0.5952798	0.9728446	0.0140338	8.0281899
3	214	199	1.9824195	2.0600650	0.0538563	7.1906238
4	214	199	1.2219970	1.7602199	0.0381365	7.6989765

Histogram of the Standard Deviation of Deceleration for all zones

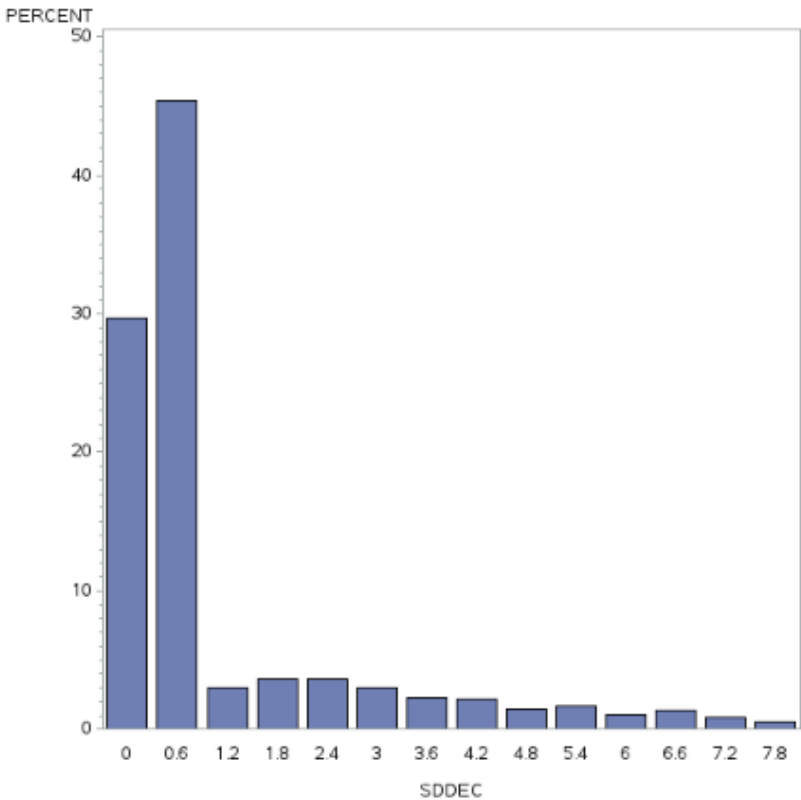

Histogram of the Standard Deviation of Deceleration for Zone 1

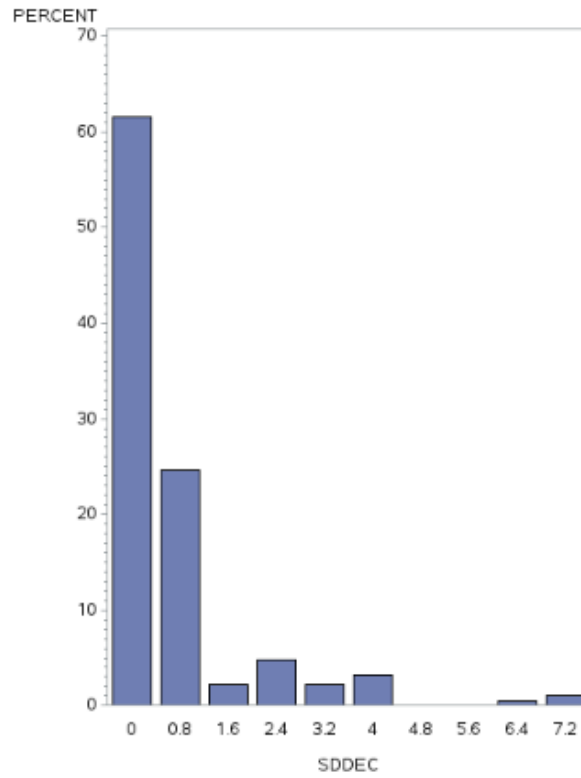

Histogram of the Standard Deviation of Deceleration for Zone 2

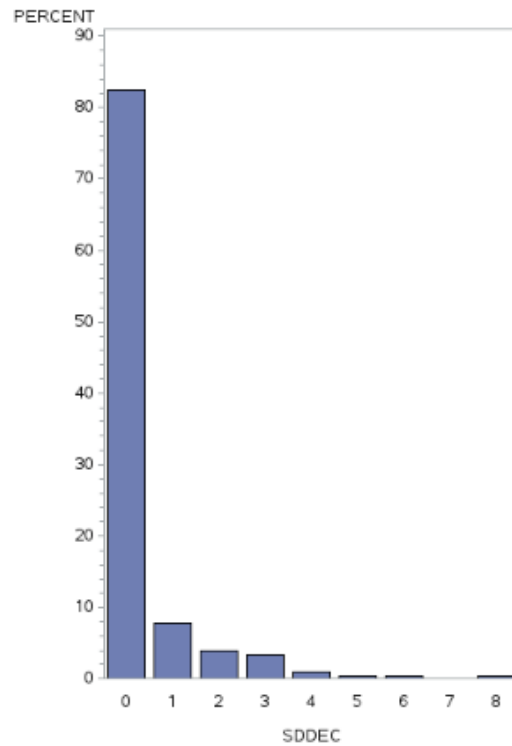



Histogram of the Standard Deviation of Deceleration for Zone 3

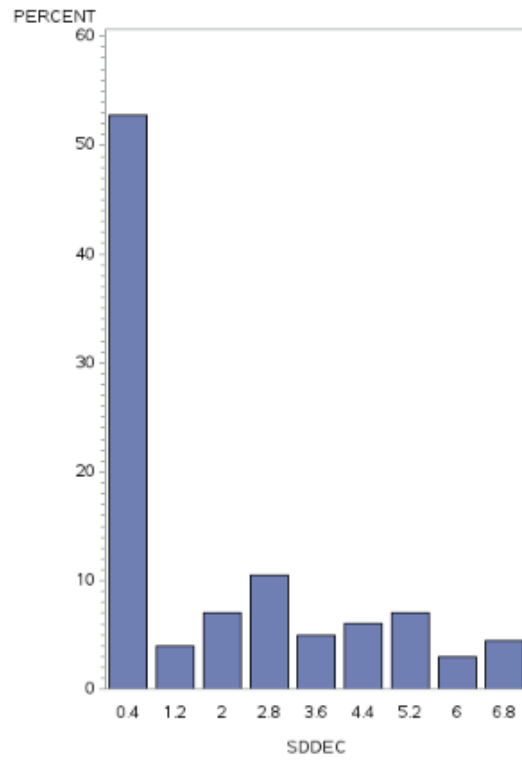

Histogram of the Standard Deviation of Deceleration for Zone 4

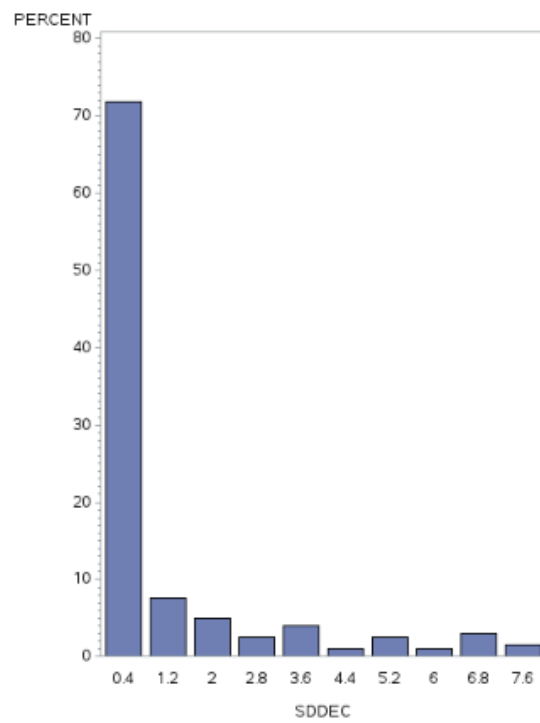

Descriptive Statistics of the Log standard deviation of deceleration for each zone

Analysis Variable : LogSDDec LogSDDec						
zone	N Obs	N	Mean	Std Dev	Minimum	Maximum
1	214	187	-0.3769899	0.3972638	-1.4866795	0.8738807
2	214	205	-0.4418221	0.3655500	-1.8528242	0.9046176
3	214	199	-0.0051444	0.5564414	-1.2687634	0.8567666
4	214	199	-0.2058117	0.4616801	-1.4186587	0.8864330

Histogram of the Log Standard Deviation of Deceleration for all zones

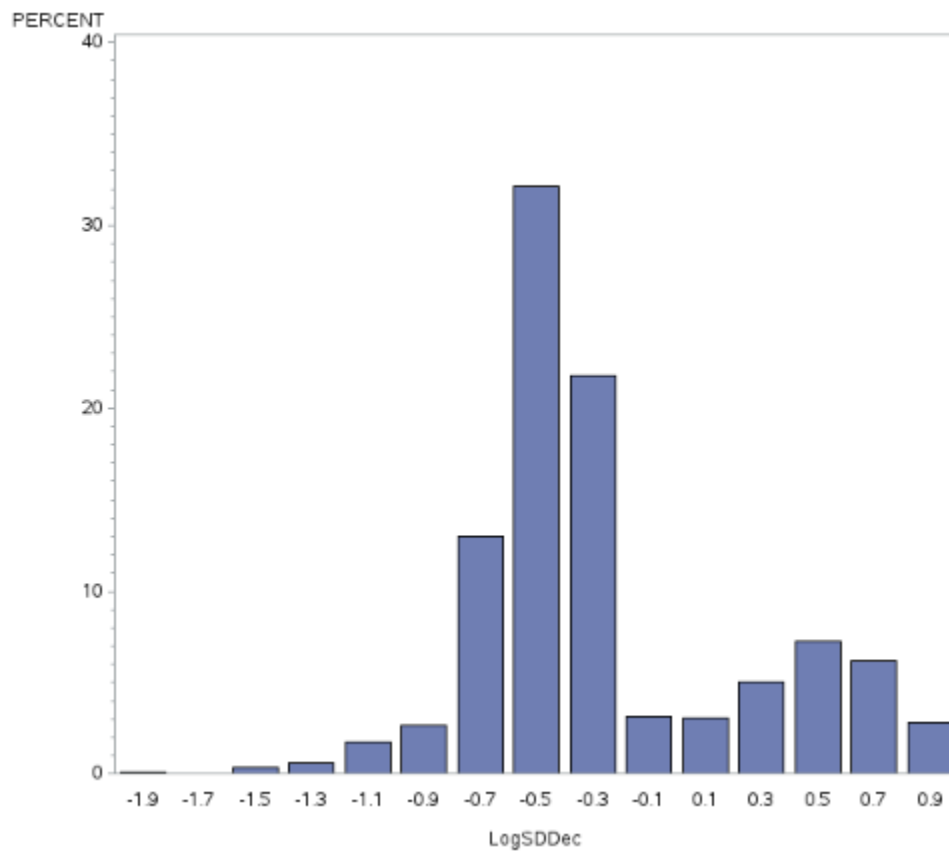

Histogram of the Log Standard Deviation of Deceleration for Zone 1

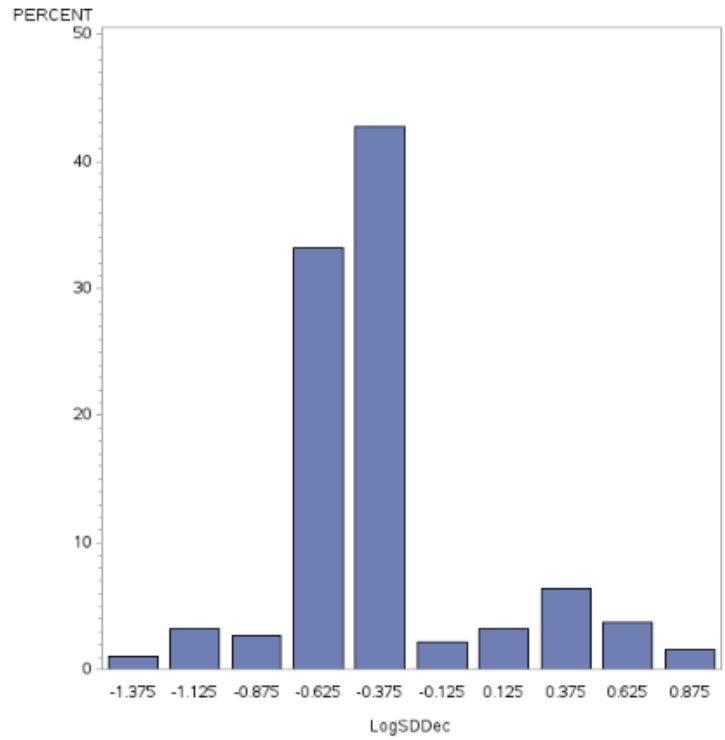

Histogram of the Log Standard Deviation of Deceleration for Zone 2

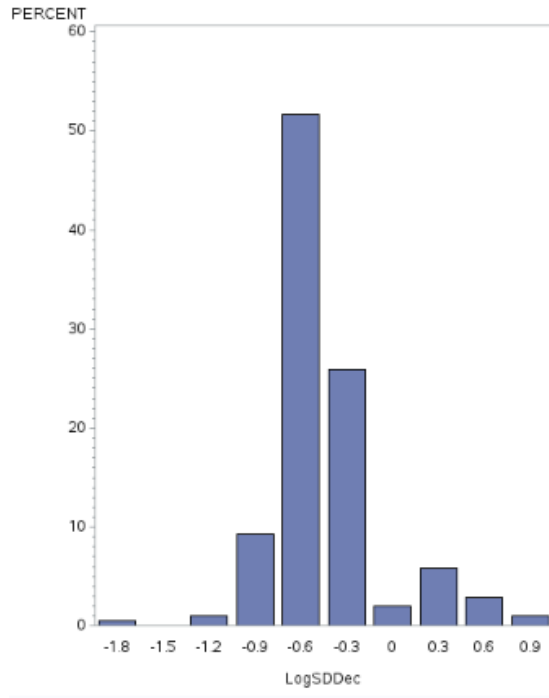

Histogram of the Log Standard Deviation of Deceleration for Zone 3

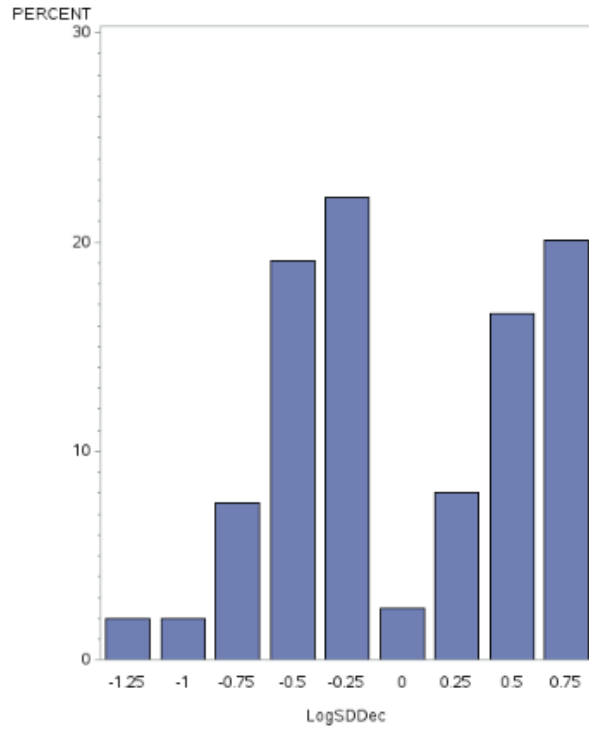

Histogram of the Log Standard Deviation of Deceleration for Zone 4

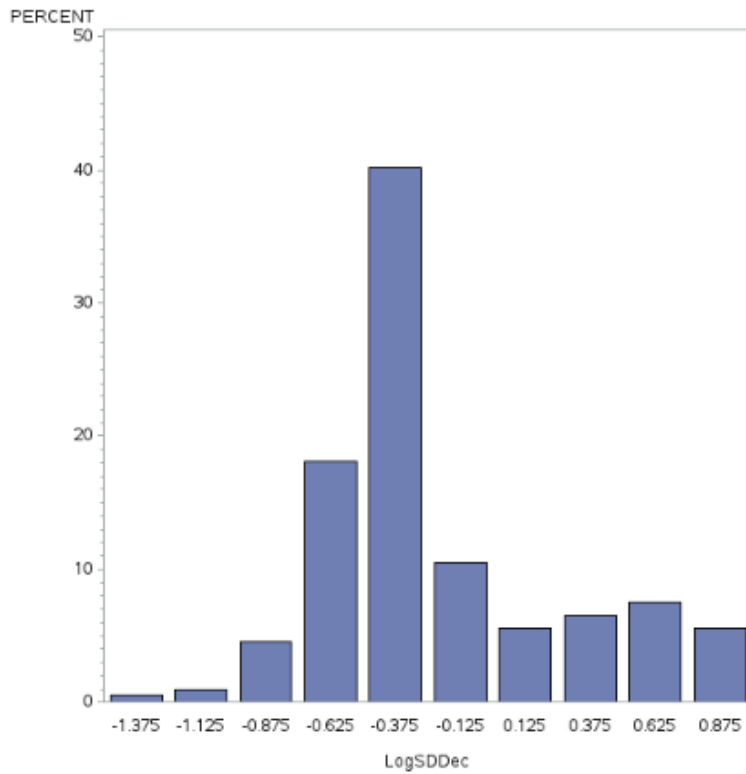

Figures of the Driver Characteristics Variables from Questionnaire

<b>Variable</b>	<b>Level</b>	<b>Description</b>	<b>Freq.</b>	<b>%</b>	<b>Cum. Freq.</b>	<b>Cum. %</b>
<b>Age</b>	1	18 to 25	23	31.94	23	31.94
	2	25 to 35	24	33.33	47	65.28
	3	35 to 50	14	19.44	61	84.72
	4	50 to 60	6	8.33	67	93.06
	5	60 or more	5	6.94	72	100
<b>Gender</b>	1	Male	38	52.78	38	52.78
	2	Female	34	47.22	72	100
<b>Driving frequency</b>	1	1 to 5 trips per week	14	19.44	14	19.44
	2	1 or 2 trips per day	17	23.61	31	43.06
	3	More than 3 trips per day	41	56.94	72	100
<b>Annual Income</b>	1	Lower than \$40,000	36	50	36	50
	2	\$40,000 or higher	36	50	72	100
<b>ETC-tag use</b>	1	Yes	57	79.17	57	79.17
	2	No	15	20.83	72	100
<b>Professional driver</b>	1	Yes	4	5.56	4	5.56
	2	No	68	94.44	72	100
<b>Novice international drivers</b>	1	Yes	3	4.17	3	4.17
	2	No	69	95.83	72	100
<b>Education</b>	1	Bachelor's degree or lower	50	69.44	50	69.44
	2	Higher than bachelor's degree	22	30.56	72	100
<b>Crash experience</b>	1	Yes	13	18.06	13	18.06

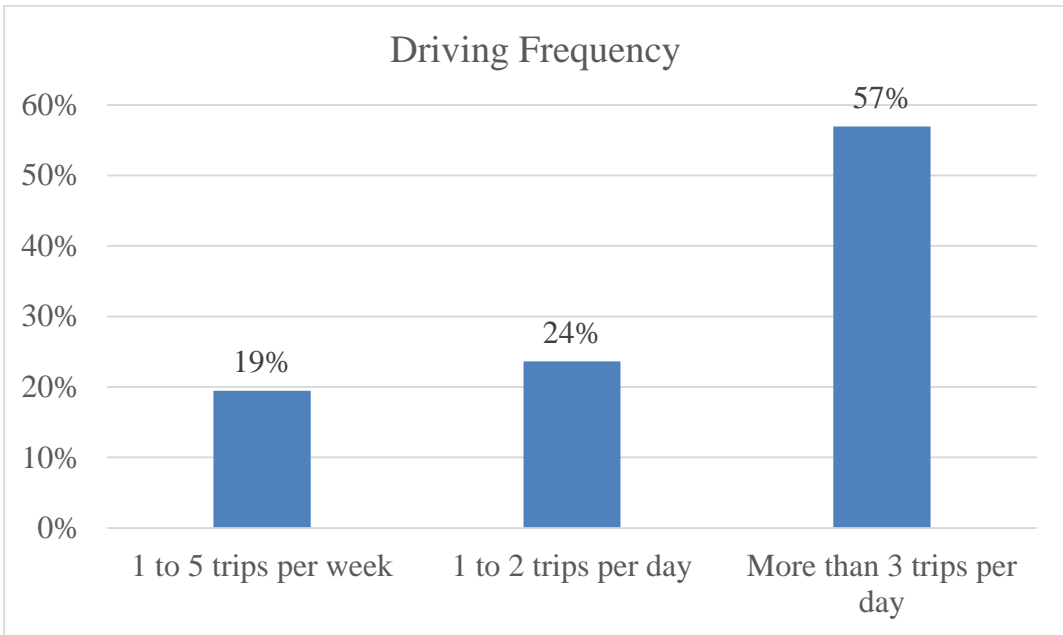
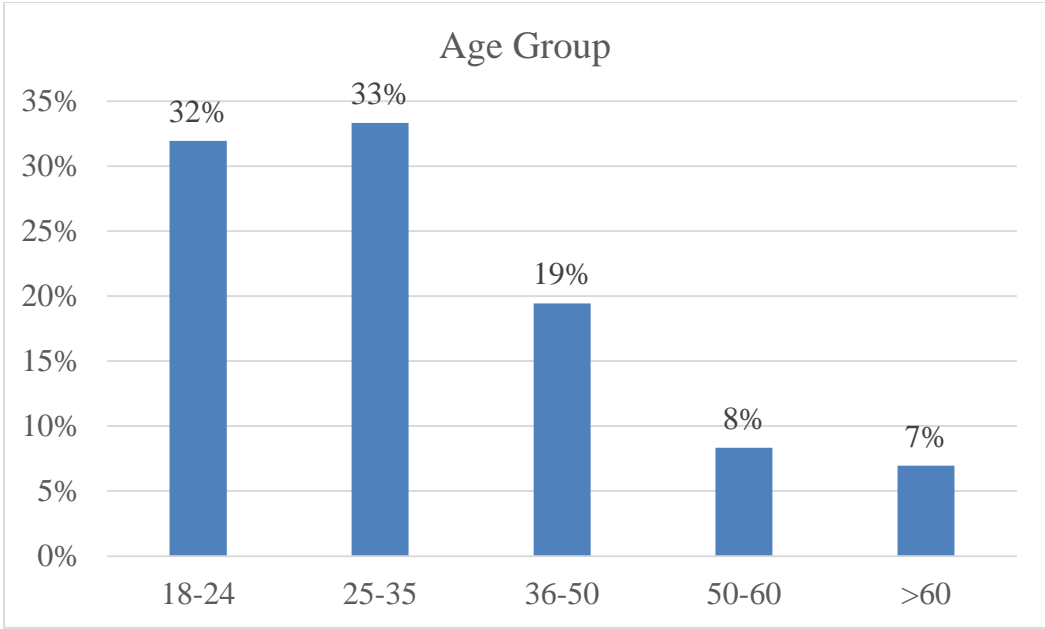

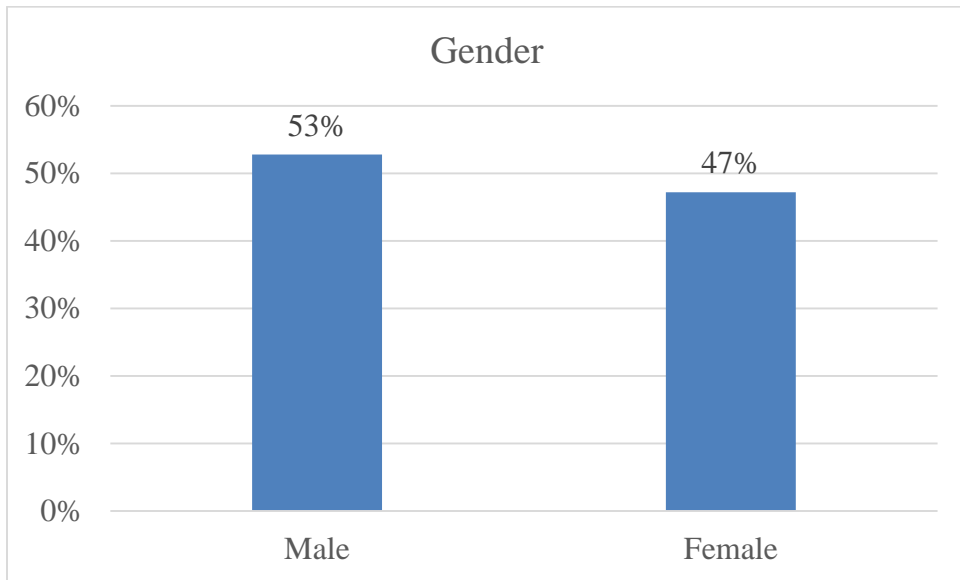
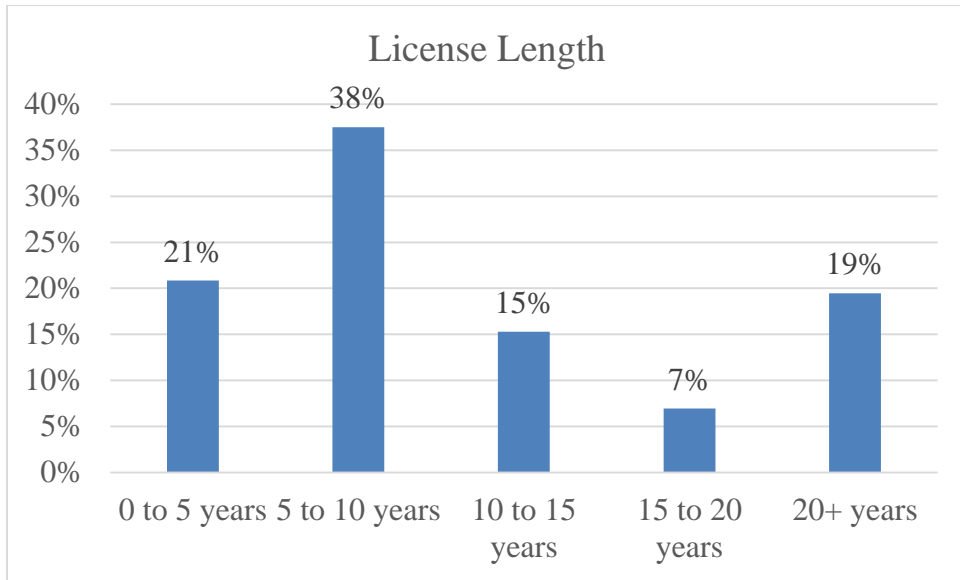

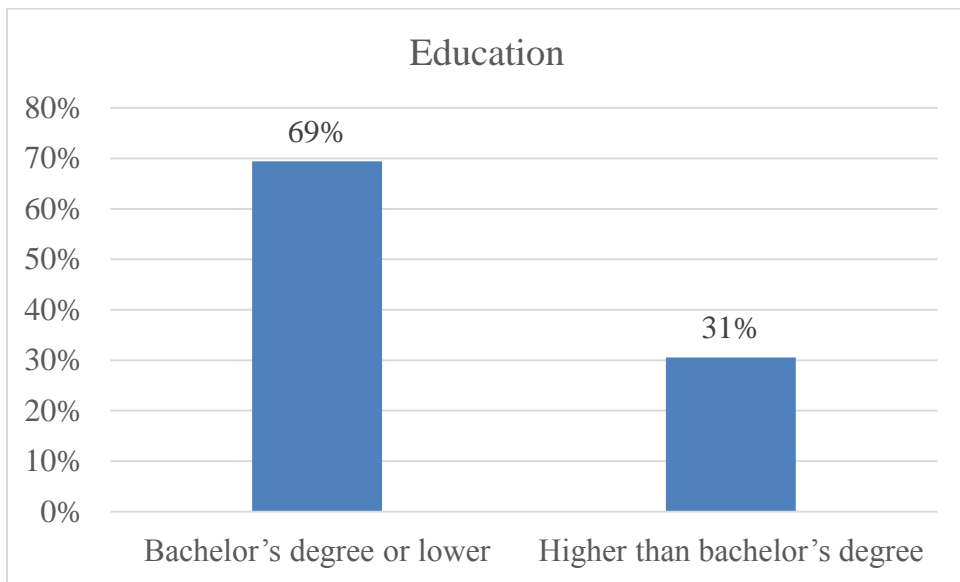
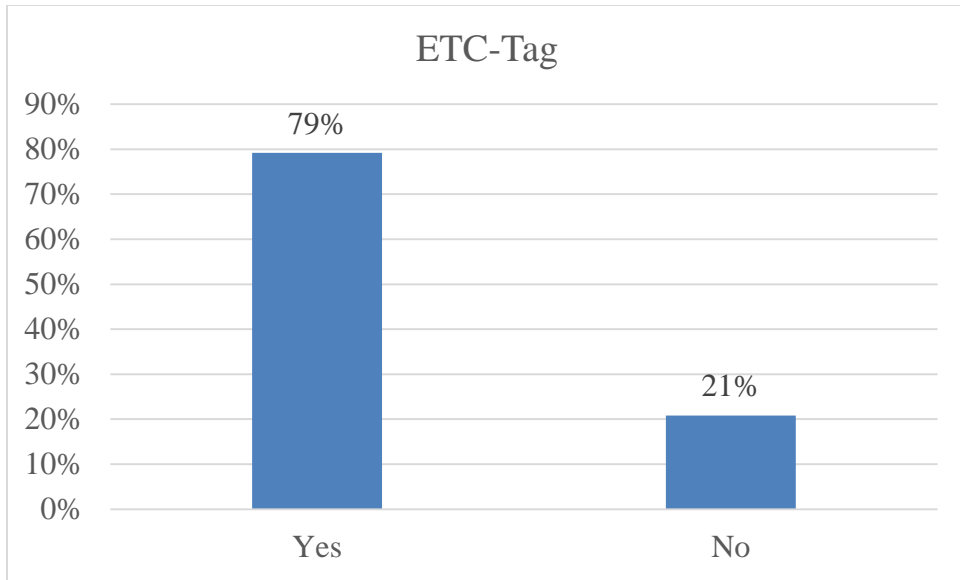



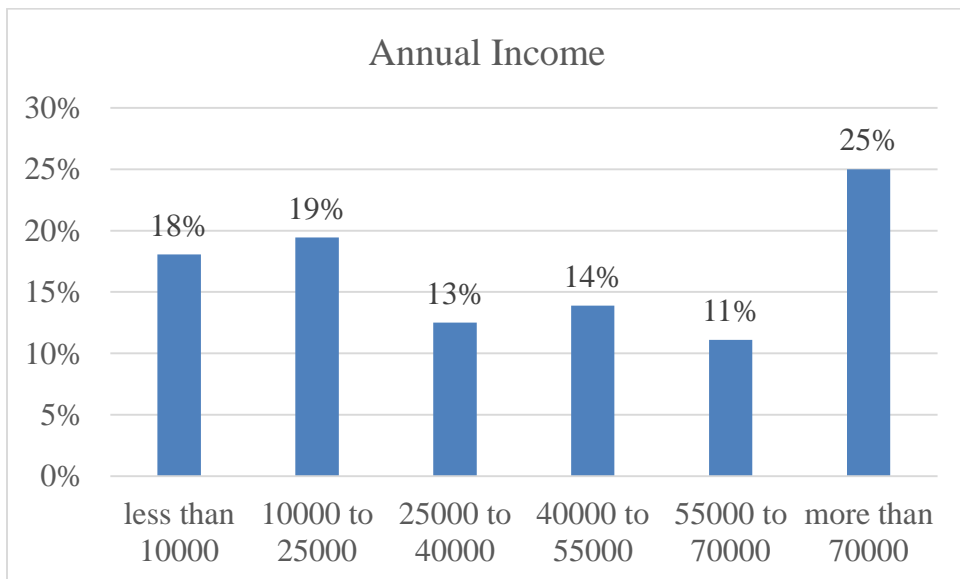
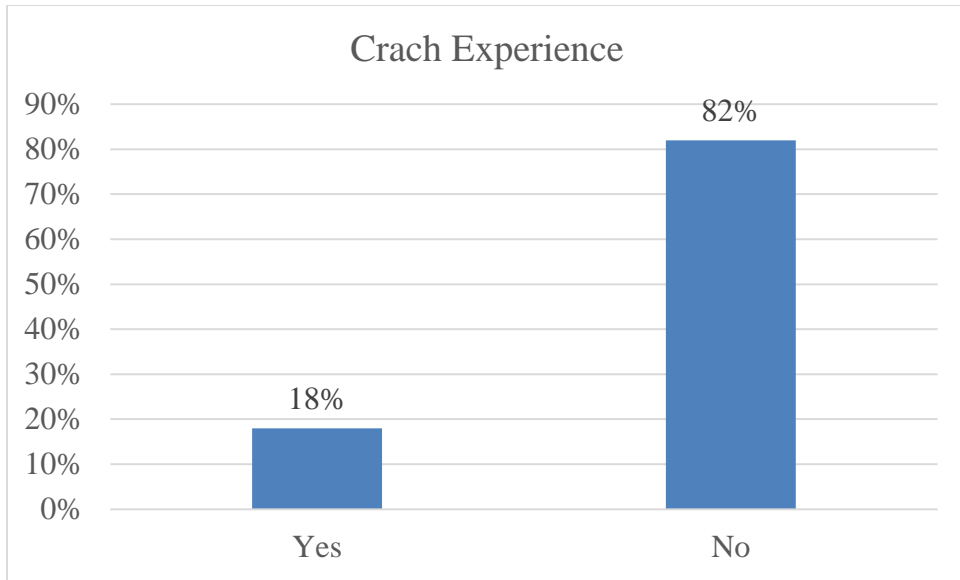

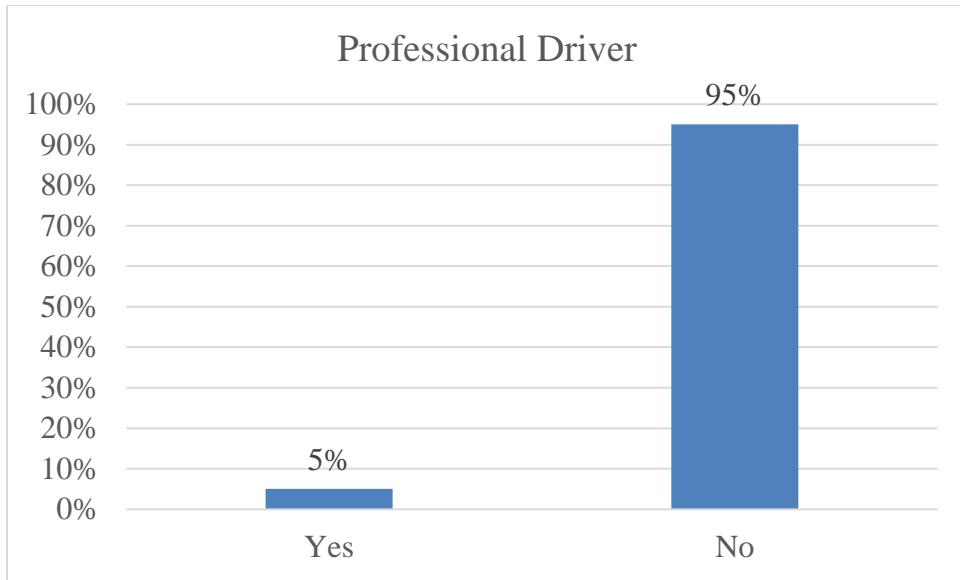

Cross-tabulate of the driving characteristics variables

Cross-tabulation of Age group and Gender

GENDER		AGE					Total
		18 to 25	25 to 35	35 to 50	50 to 60	60+	
Male	Frequency	10	13	8	2	5	38
	Percent	13.89%	18.06%	11.11%	2.78%	6.94%	52.78%
Female	Frequency	13	11	6	4	0	34
	Percent	18.06%	15.28%	8.33%	5.56%	0	47.22%
Total	Frequency	23	24	14	6	5	72
	Percent	31.94%	33.33%	19.44%	8.33%	6.94%	100%

Percentages of Males and Females for each Age Group

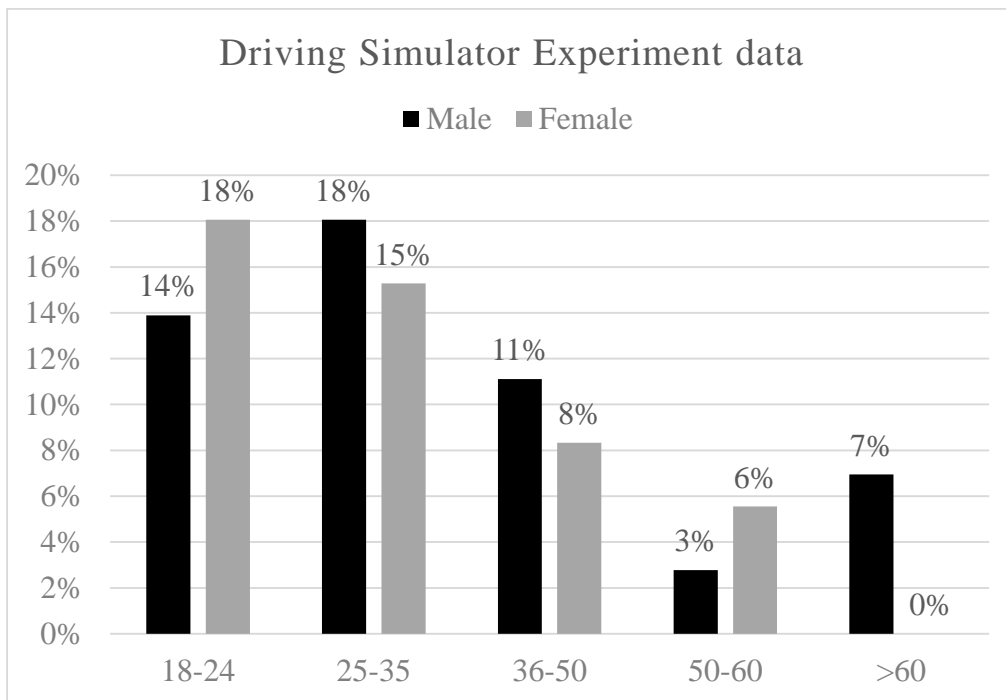

### Cross-Tabulation Age Group and ETC-Tag

ETC-Tag		AGE					Total
		18 to 25	25 to 35	35 to 50	50 to 60	60+	
Yes	Frequency	17	21	10	5	4	57
	Percent	23.61%	29.17%	13.89%	6.94%	5.56%	79.17%
No	Frequency	6	3	4	1	1	15
	Percent	8.33%	4.17%	5.56%	1.39%	1.39%	20.83%
Total	Frequency	23	24	14	6	5	72
	Percent	31.94%	33.33%	19.44%	8.33%	6.94%	100%

Percentage of ETC-tag ownership for each Age group

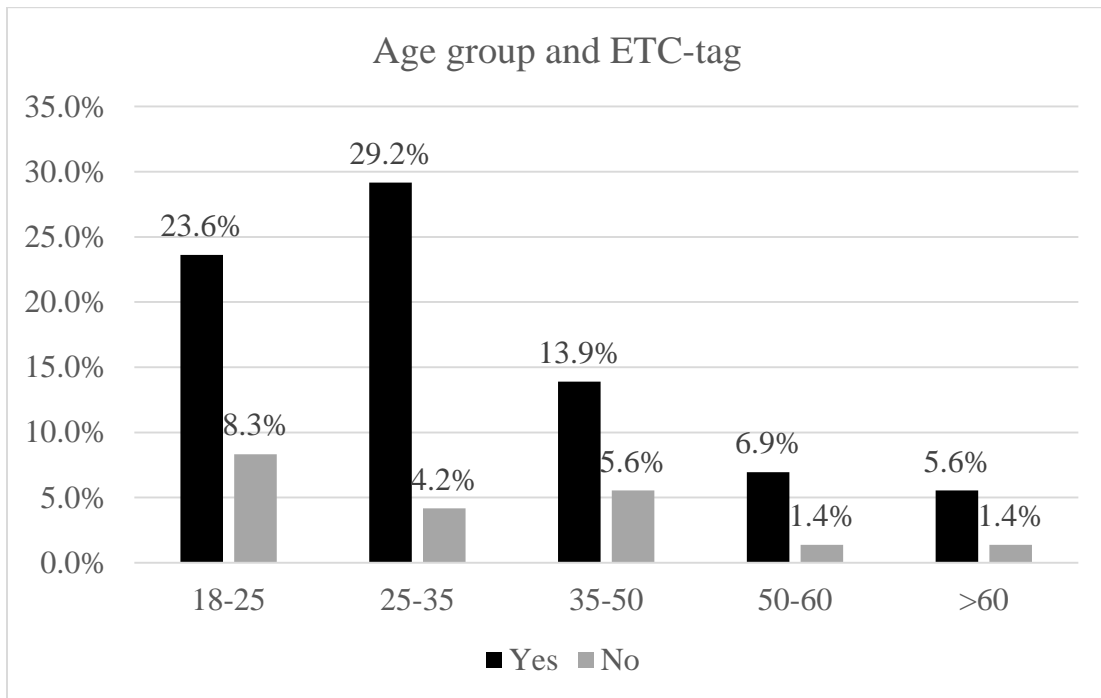

Figures of the Scenario Variables

Variable	Level	Description	Freq.	%	Cum. Freq.	Cum. %
Path	1	Mainline-Open Tolling- Mainline	13	18.06	13	18.06
	2	Mainline-Cash Tollbooth- Mainline	11	15.28	24	33.33
	3	Mainline-Open Tolling-Off Ramp	15	20.83	39	54.17
	4	On Ramp- Open Tolling - Mainline	15	20.83	54	75
	5	On Ramp- Cash Tollbooth - Mainline	18	25	72	100
Signage	1	Case 1 (base)	26	36.11	26	36.11
	2	Case 2 (install DMS and relocate the signs)	13	18.06	39	54.17
	3	Case 3 (remove third sign)	33	45.83	72	100
Extending auxiliary lanes	1	Add 660 after toll plaza	26	36.11	26	36.11
	2	Add 660 before toll plaza	13	18.06	39	54.17
	3	No change (base)	33	45.83	72	100
Traffic Condition	1	Off-peak	35	48.61	35	48.61
	2	Peak	37	51.39	72	100
Pavement Marking	1	Not Exist	34	47.22	34	47.22
	2	Exist	38	52.78	72	100

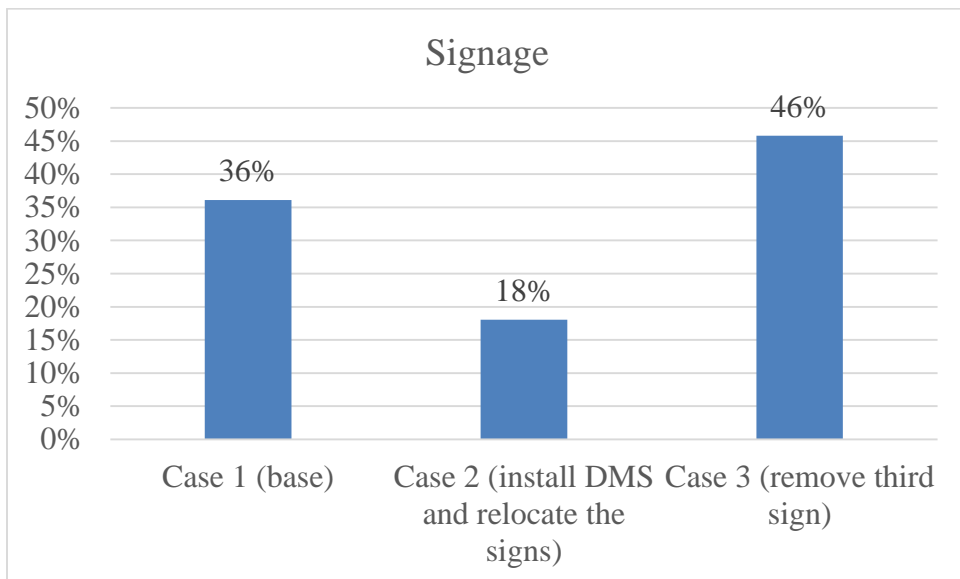
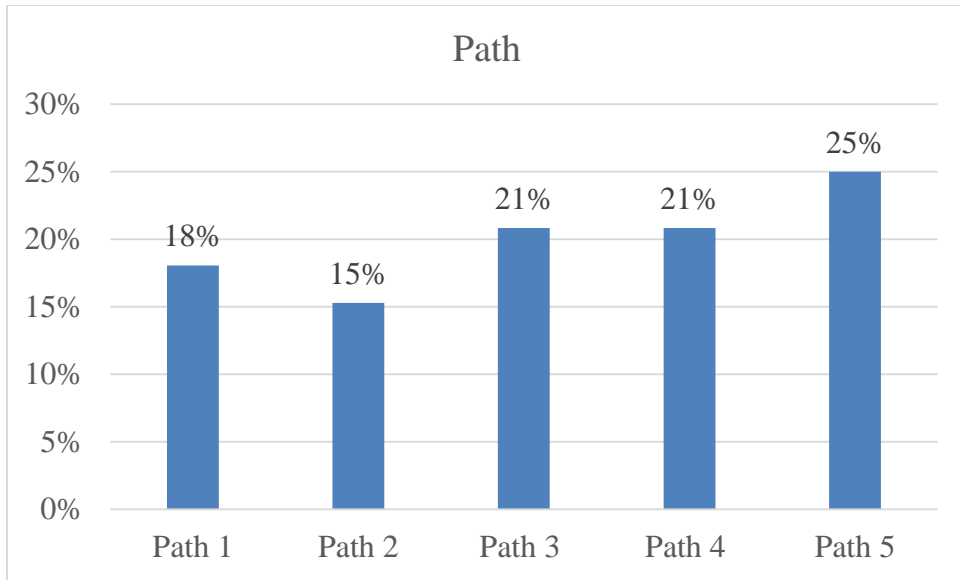

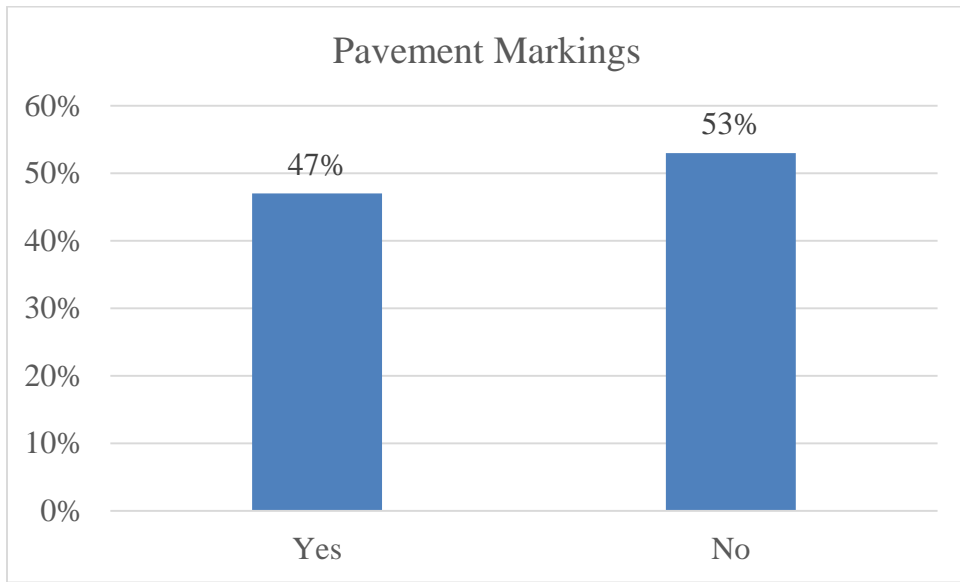
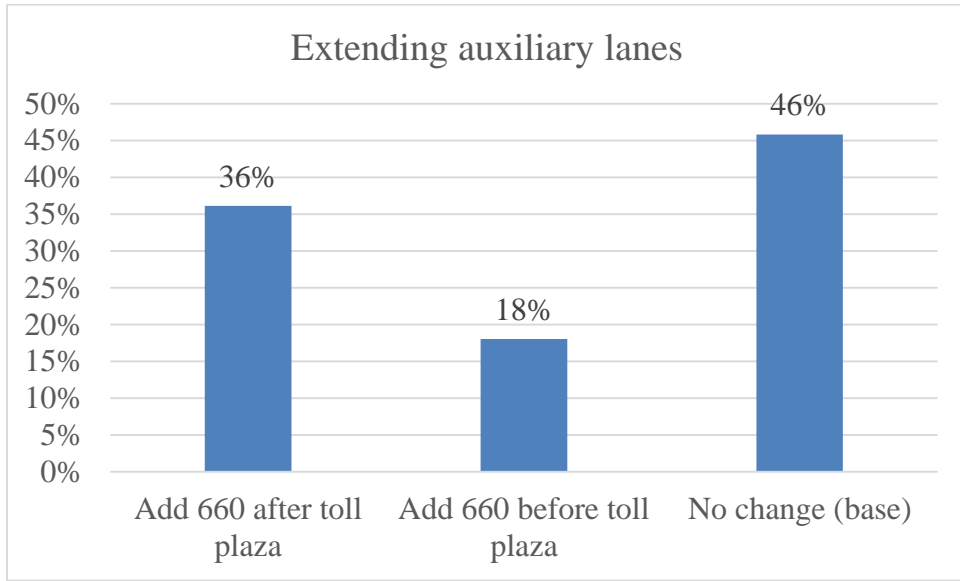

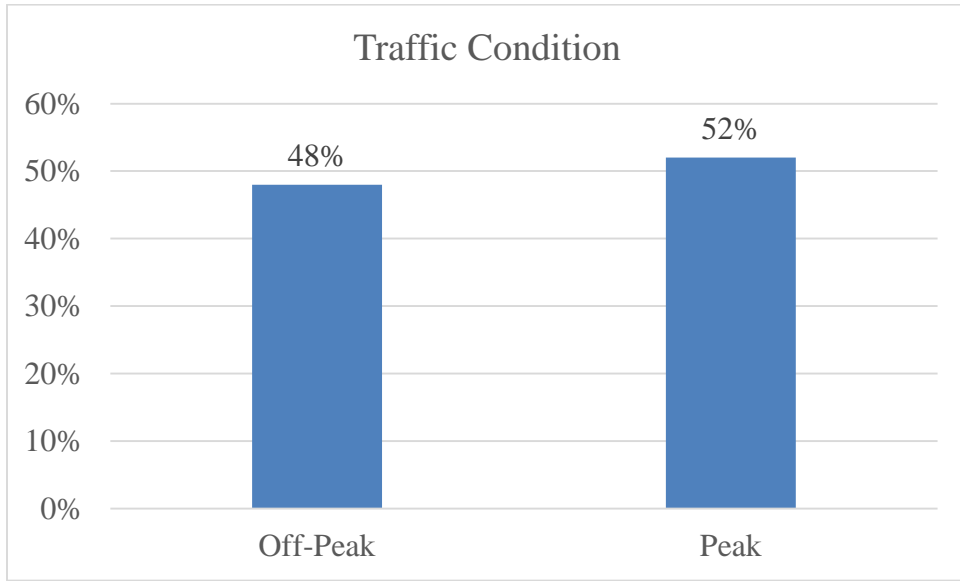

### Plots of the Relation between Path and Driving Behavior Variables

#### Relation between Speed and Path for each zone

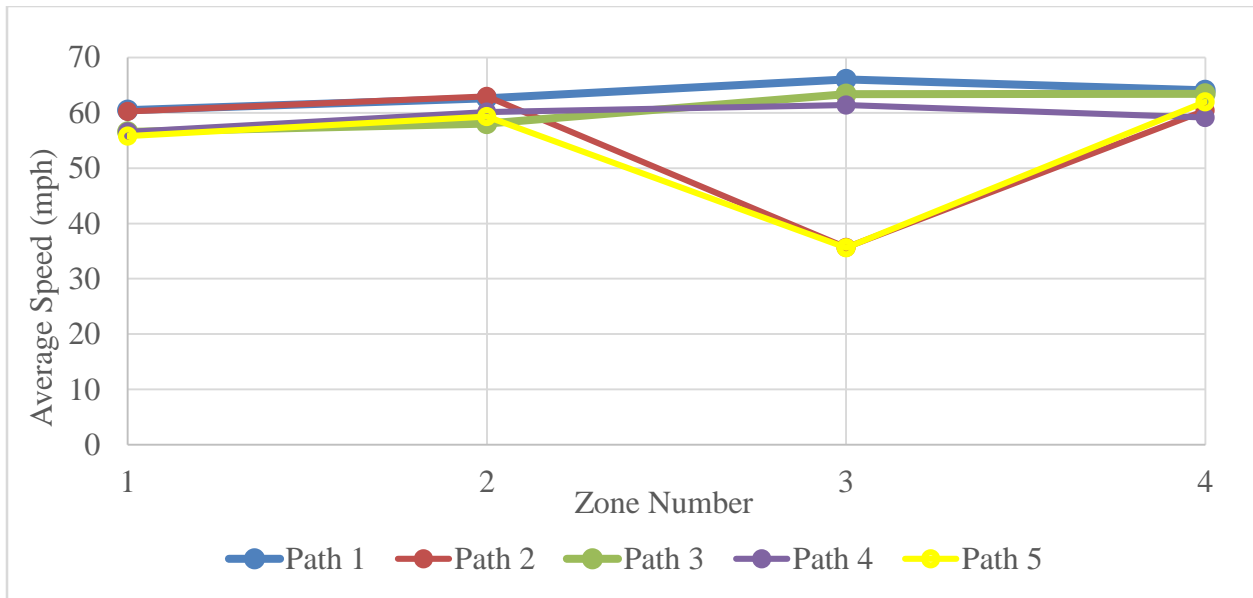



Relation between Log Standard Deviation of Speed and Path for each zone

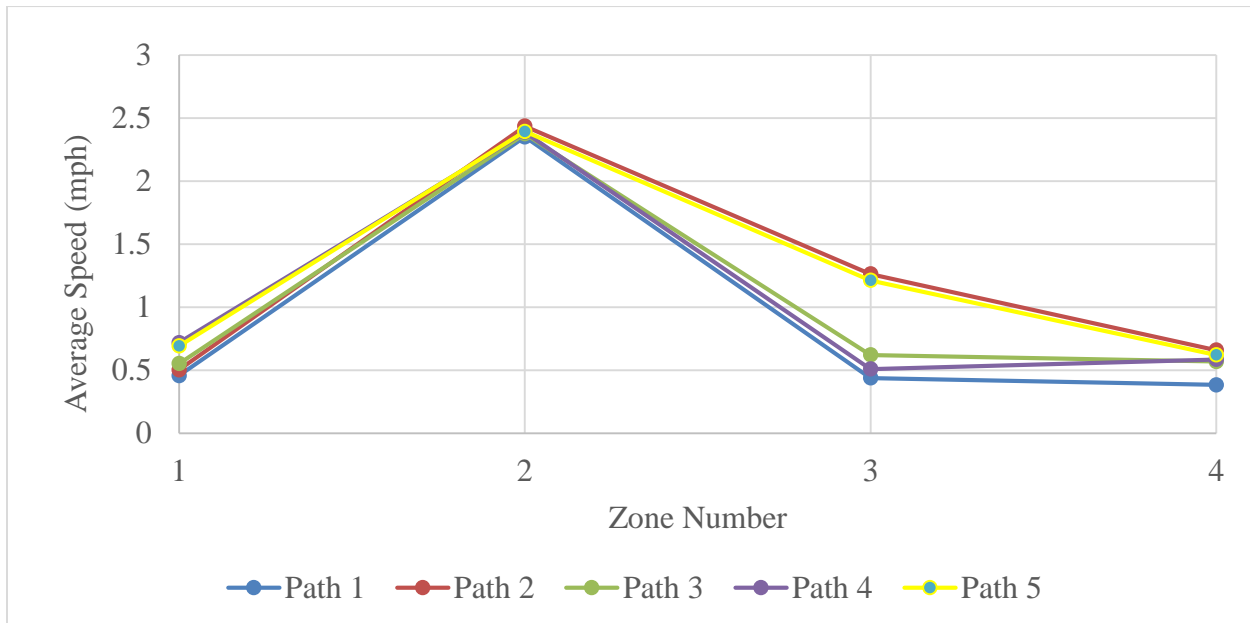

Relation between Standard Deviation of Lane Deviation and Path for each zone

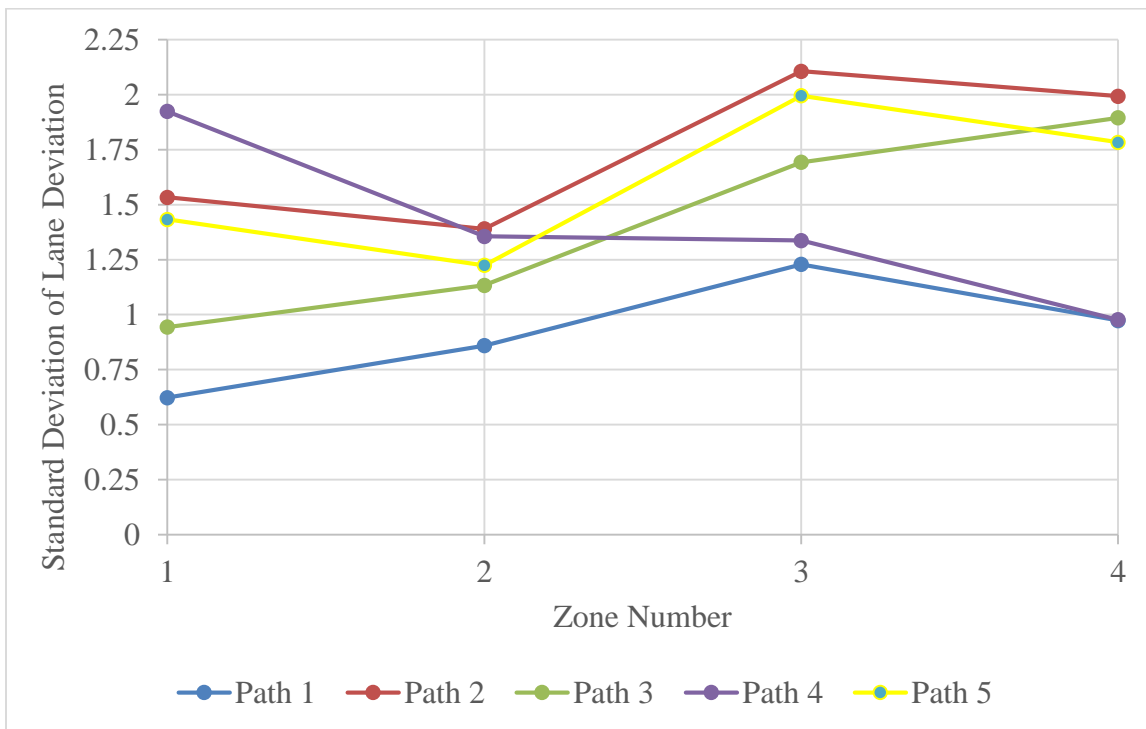

Relation between Acceleration Noise and Path for each zone

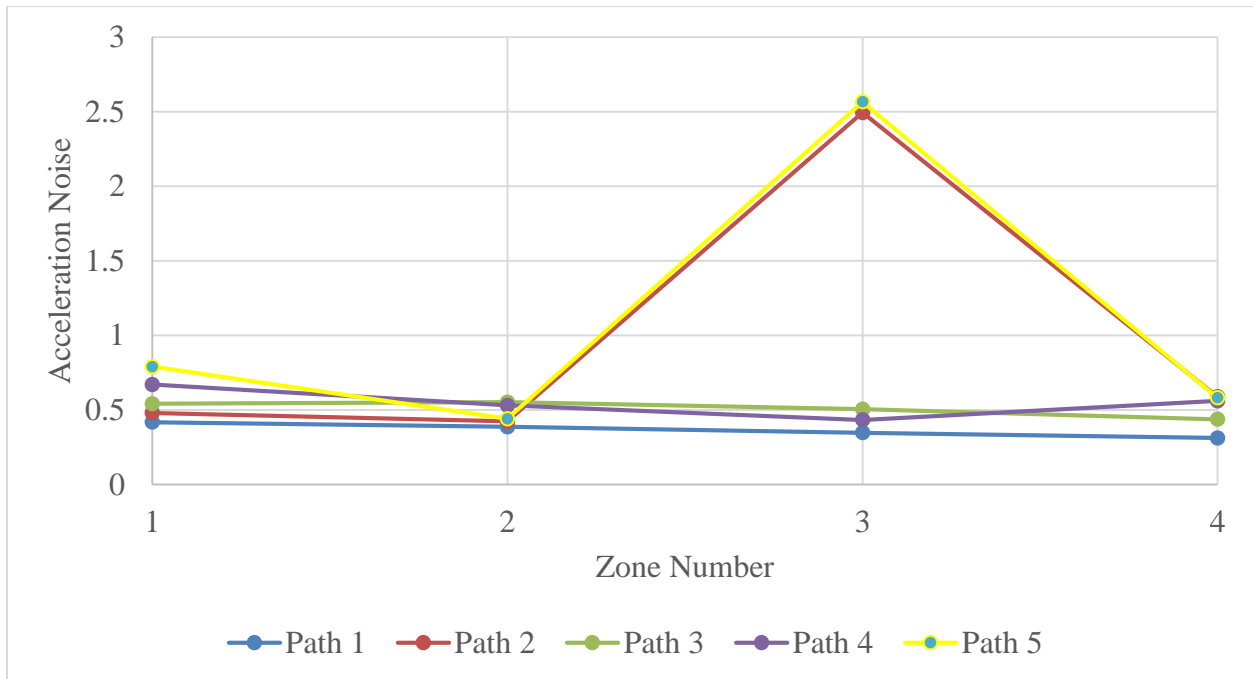

Relation between Log Acceleration and Path for each zone

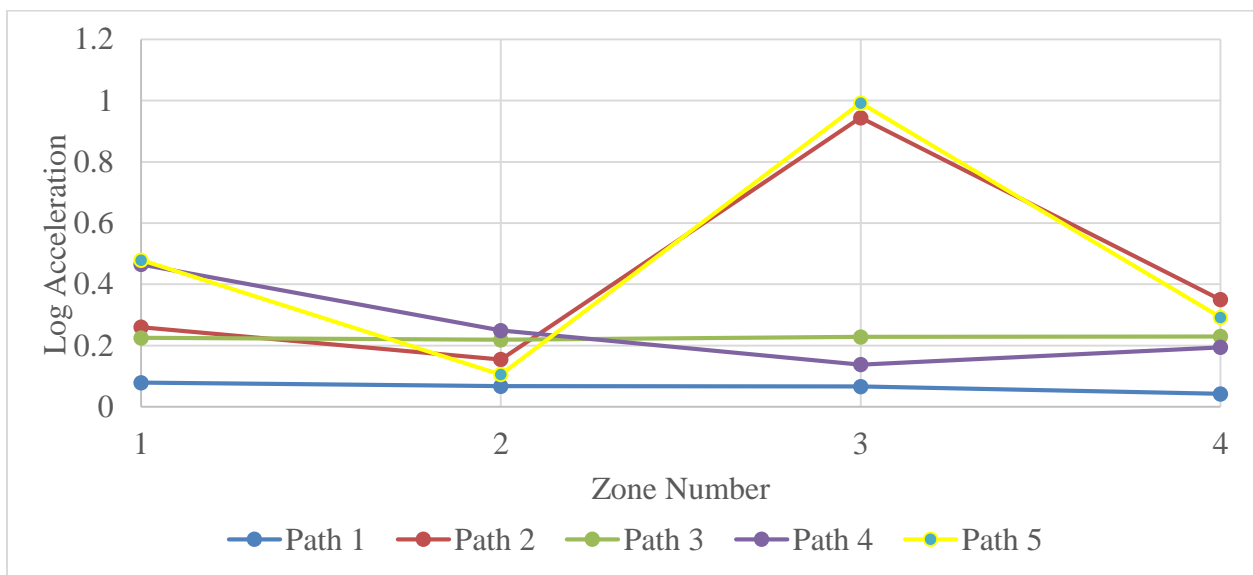

Relation between Log Deceleration and Path for each zone

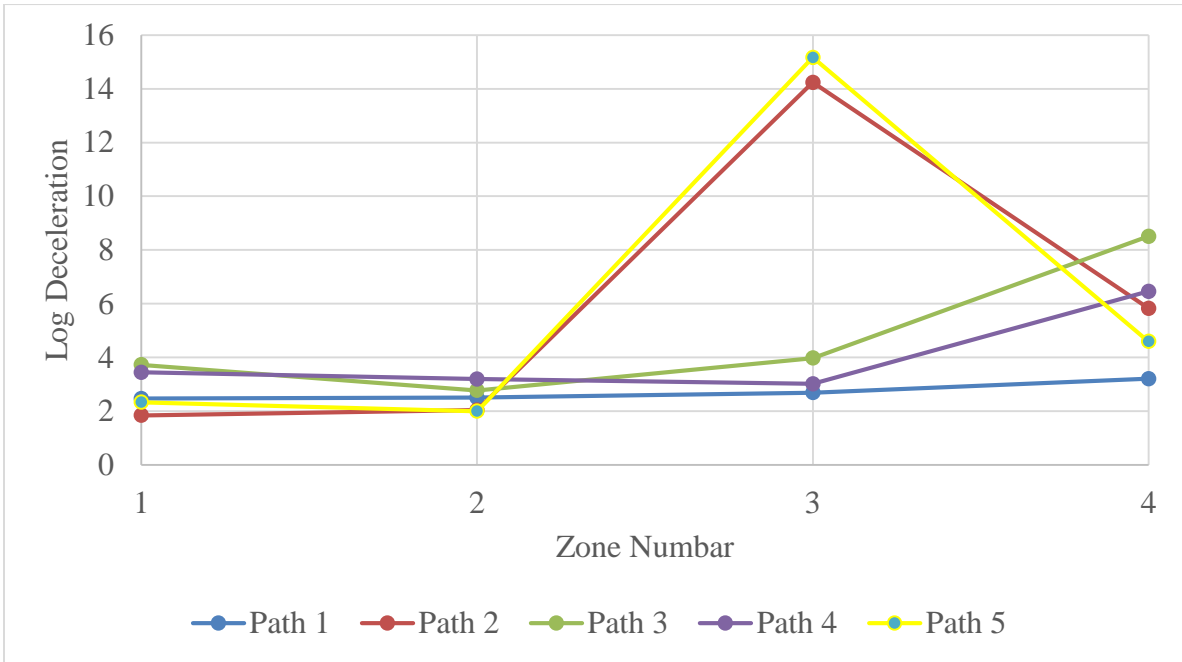

Relation between Log Standard Deviation of Deceleration and Path for each zone

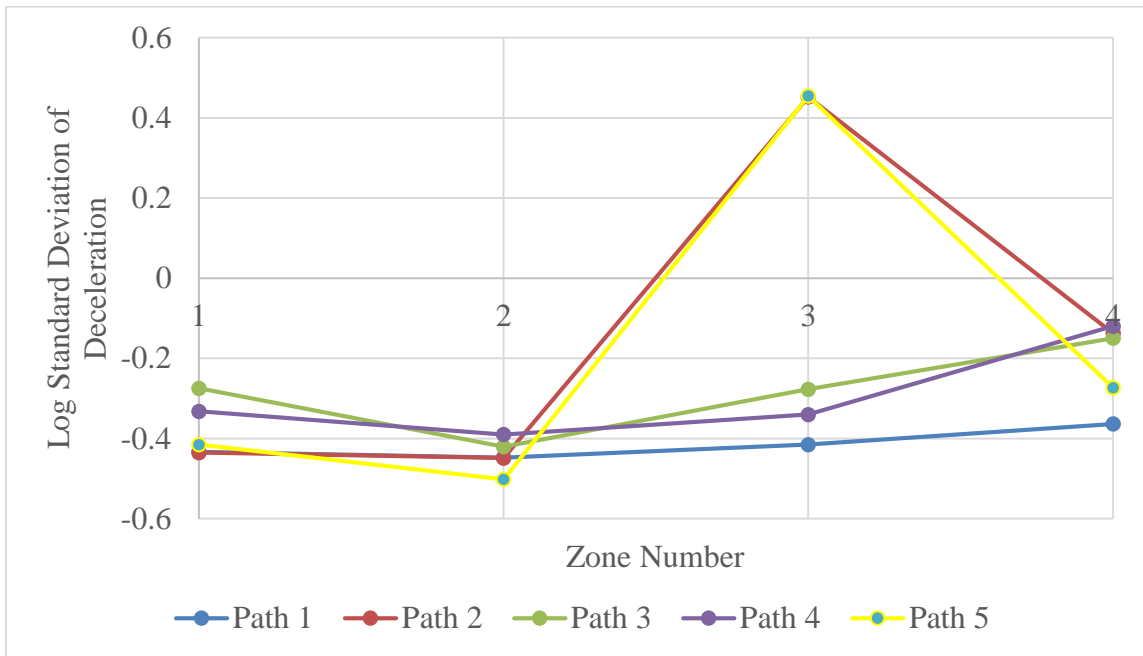

Box Plots for significant variables for each driving behavior variables

Boxplot of the relation between Average Speed and Pavement Marking Cases (1 No Markings, 2 Markings exist) at zone 3

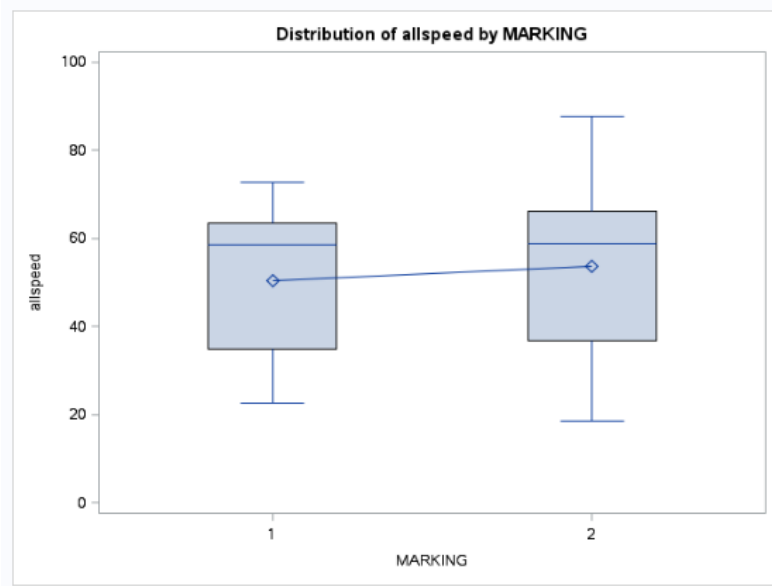

Boxplot of the relation between average speed and ETC-tag familiarity (0: not familiar 1: familiar) at zone 4

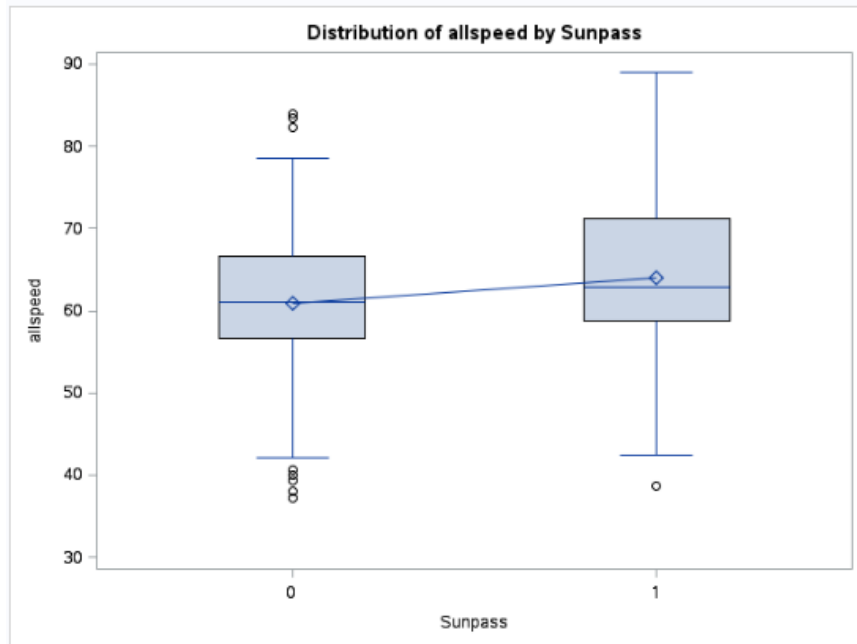

Relation between Log standard deviation of speed and pavement marking cases (1 No Marking, 2 Marking) at zone 3

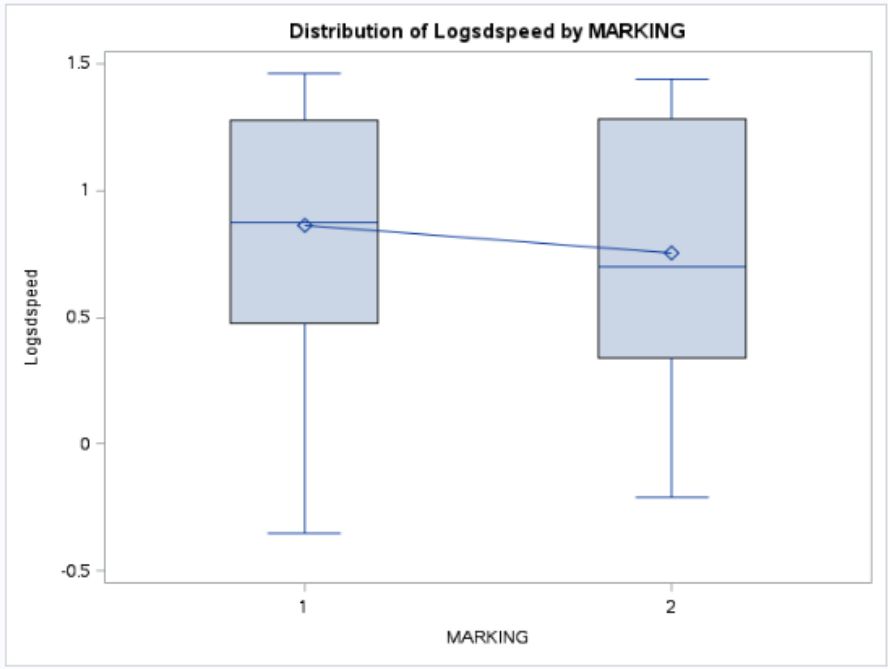

Relation between Log standard deviation of speed and gender (0 male, 1 female) at zone 1

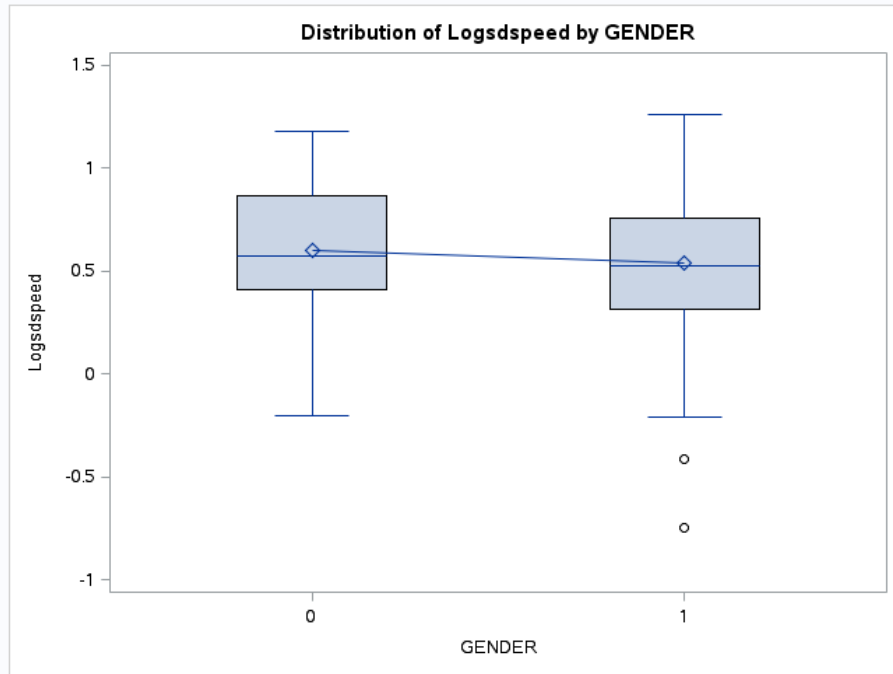

Relation between Log Standard Deviation of speed and age groups at zone 4

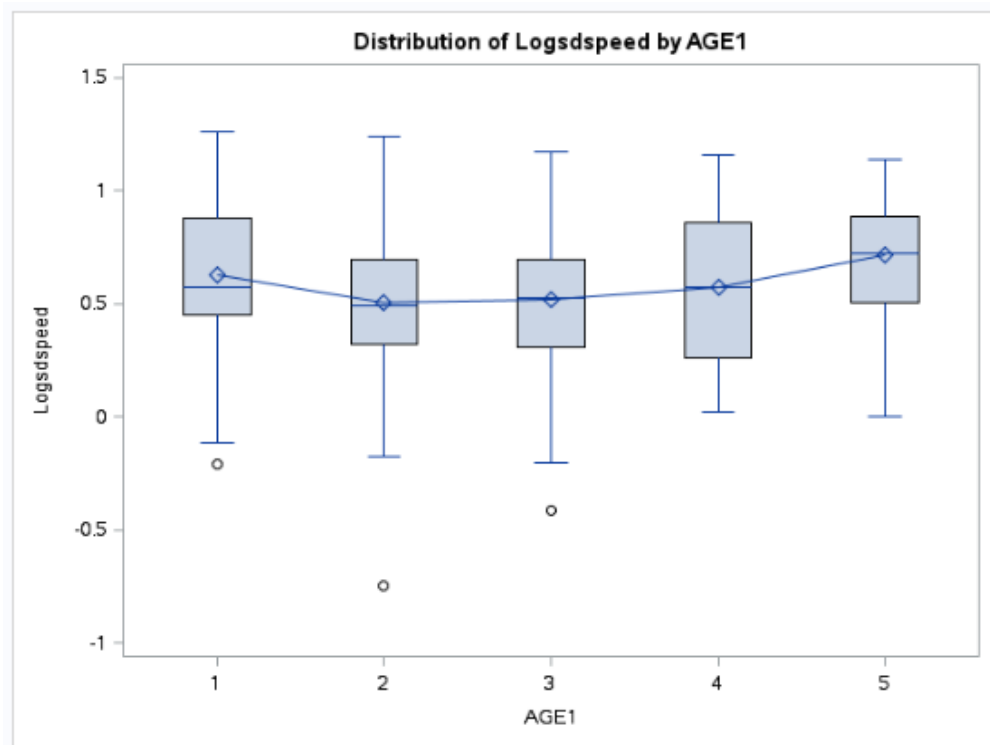

Relation between standard deviation of lane deviation and driving frequency groups at zone 1

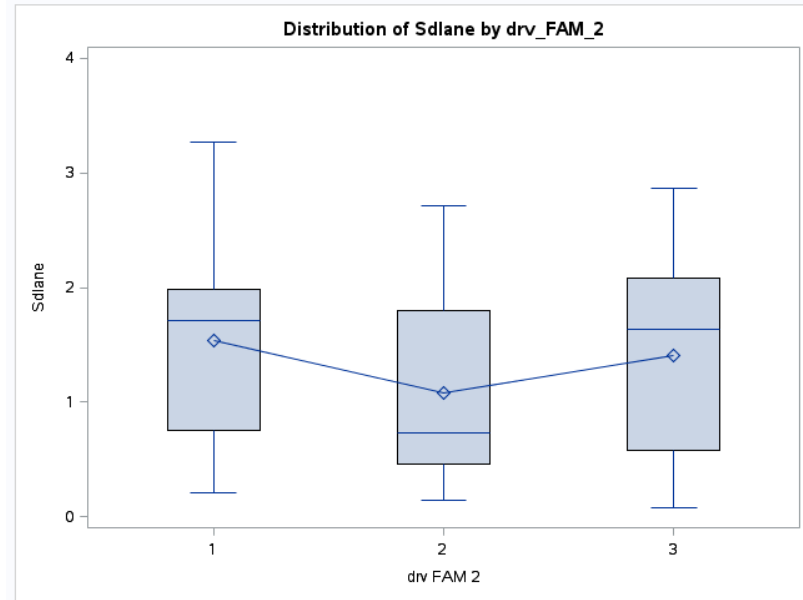

Relation between Standard Deviation of Lane Deviation and Length Groups at zone 1

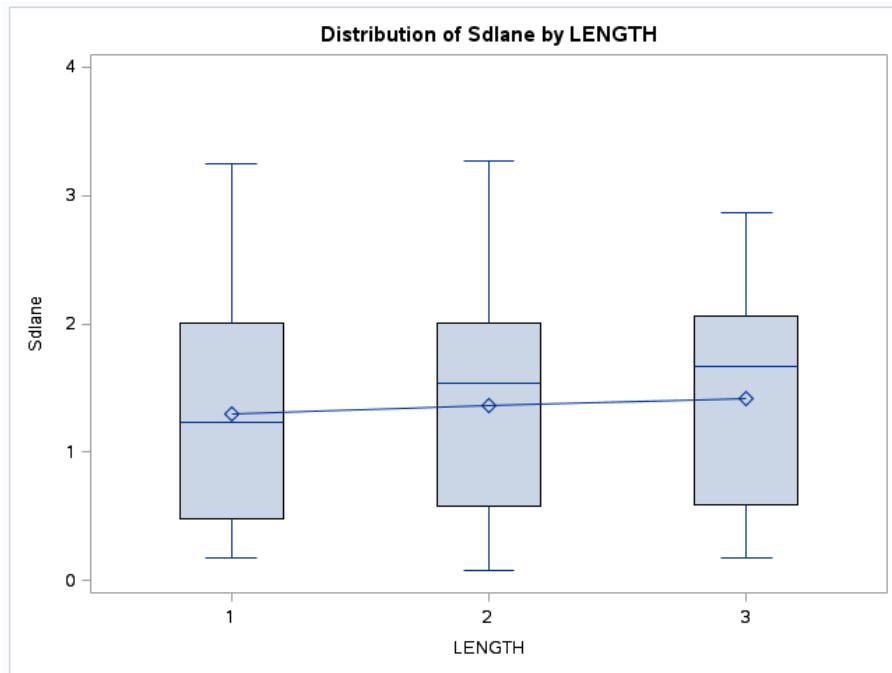

## Relation between Standard Deviation of Lane Deviation and Signage Groups at zone 4

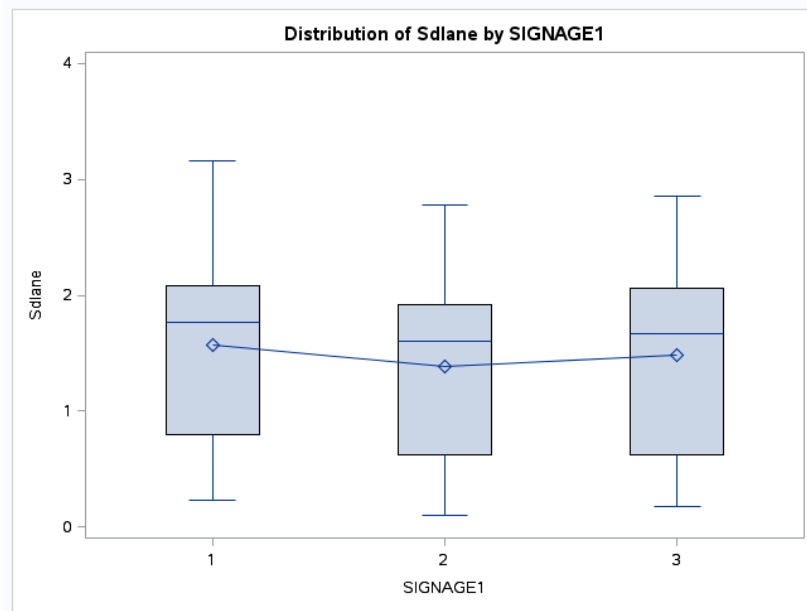

## Relation between Acceleration Noise and Pavement Markings at zone 2

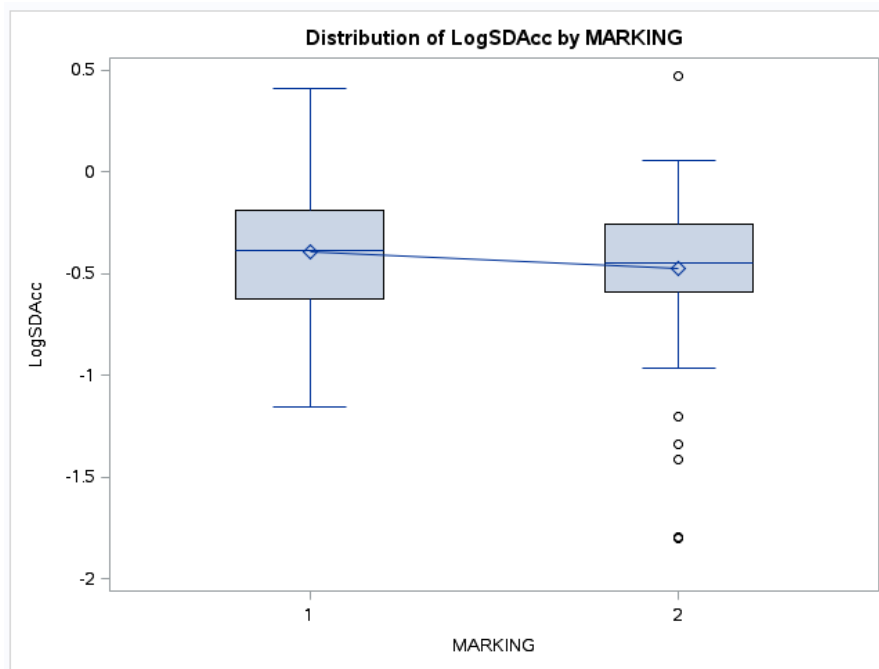



### Relation between Acceleration Noise and Traffic Conditions at zone 4

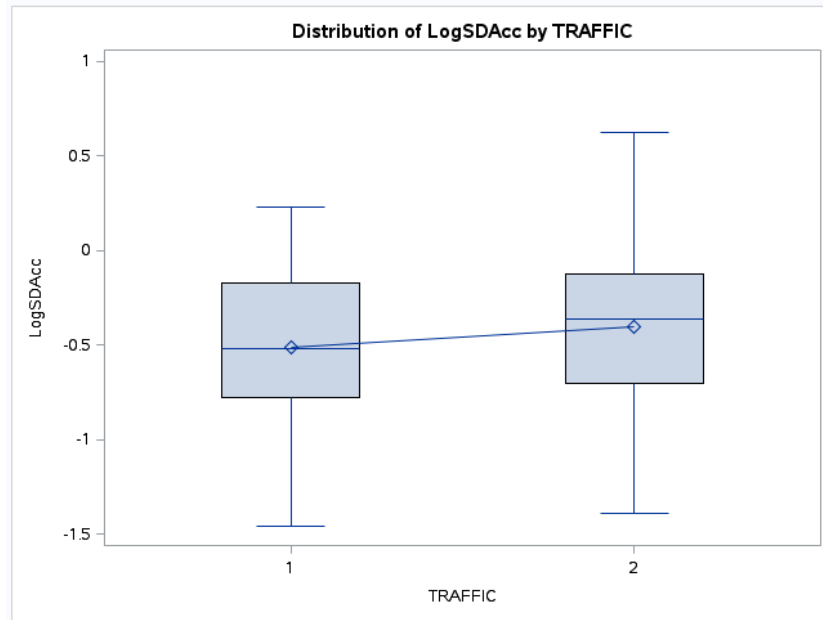

### Relation between Acceleration Noise and Auxiliary lane length at zone 4

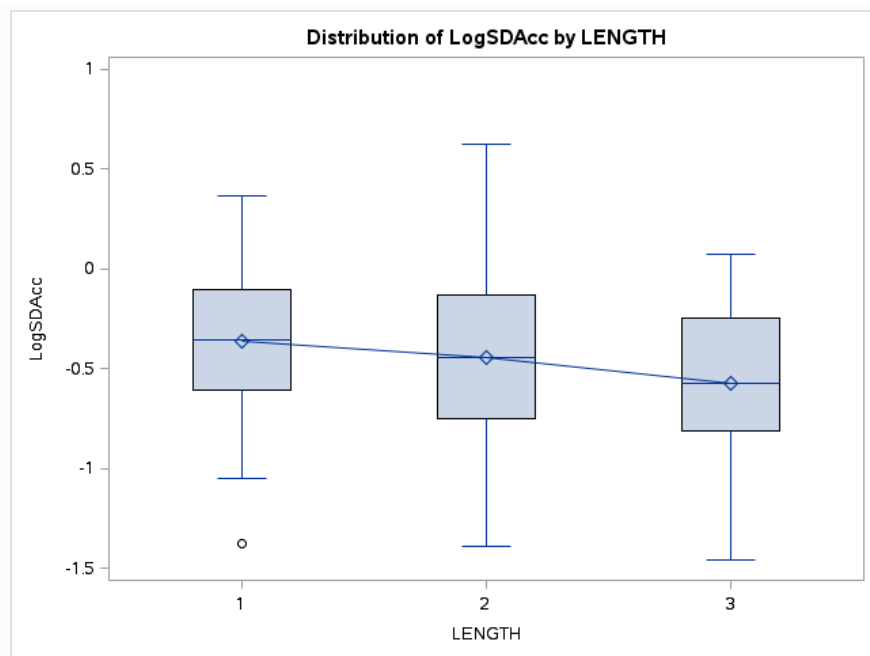

Relation between Acceleration and Traffic Conditions at zone 4 (1 off-peak 2 Peak)

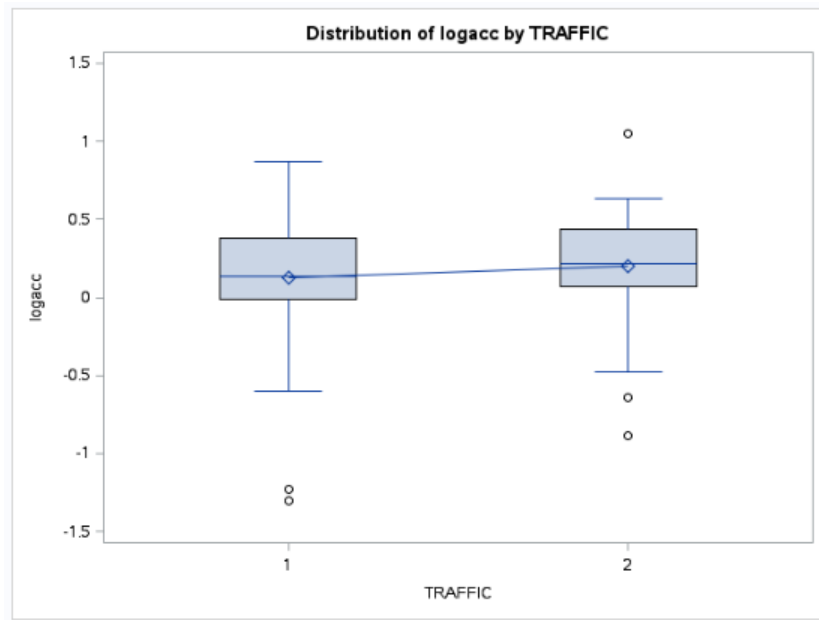

Relation between Acceleration and Pavement Markings at zone 2 (1 no Markings 2 Markings)

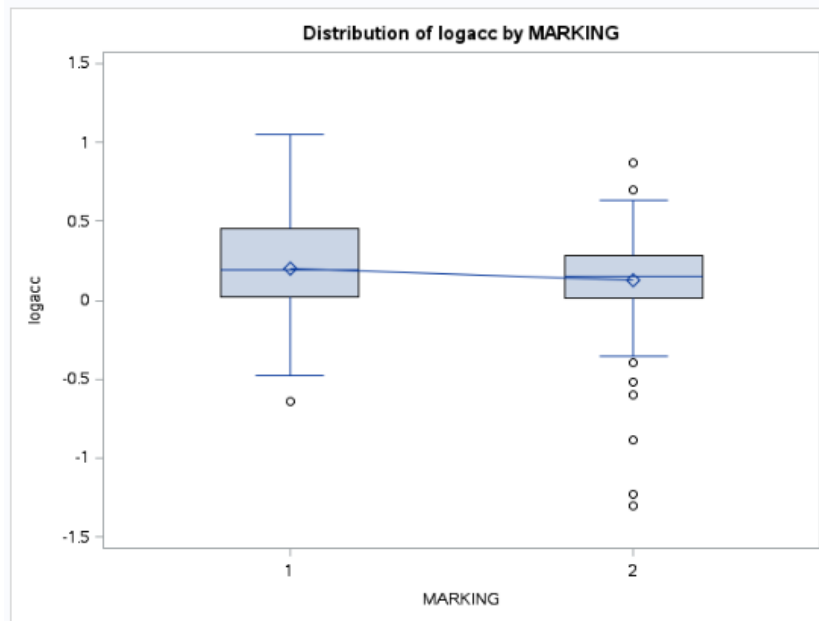

### Relation between Acceleration and Extending Auxiliary Length Conditions at zone 4

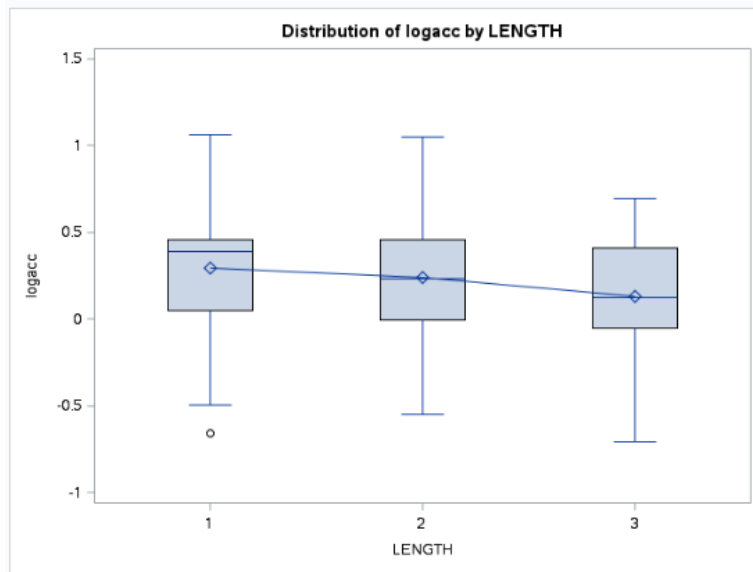

### Relation between Log Deceleration and Crash Experience at zone 4

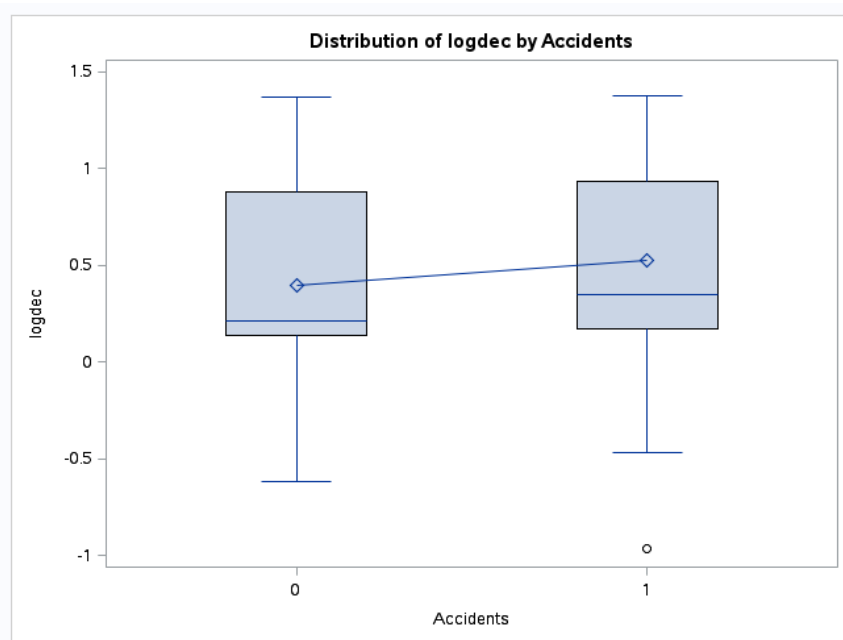

### Relation between Log Deceleration and Traffic Conditions at zone 3

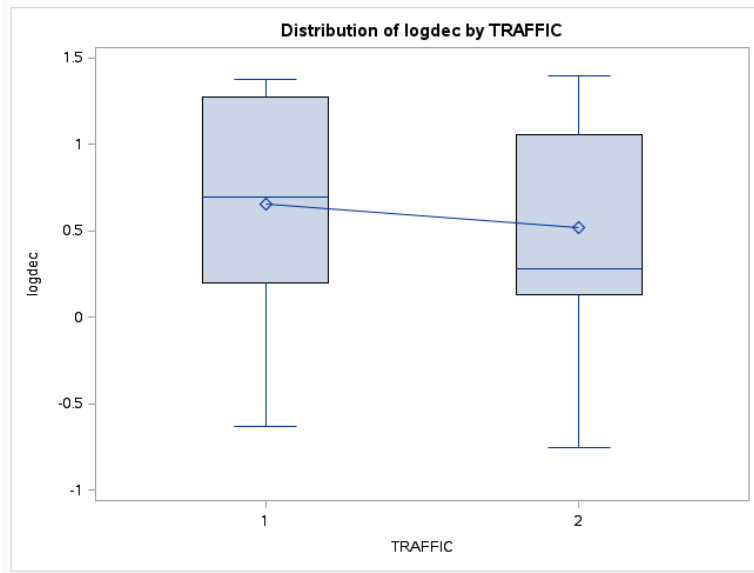

### Relation between Log Deceleration and Length Conditions at zone 4

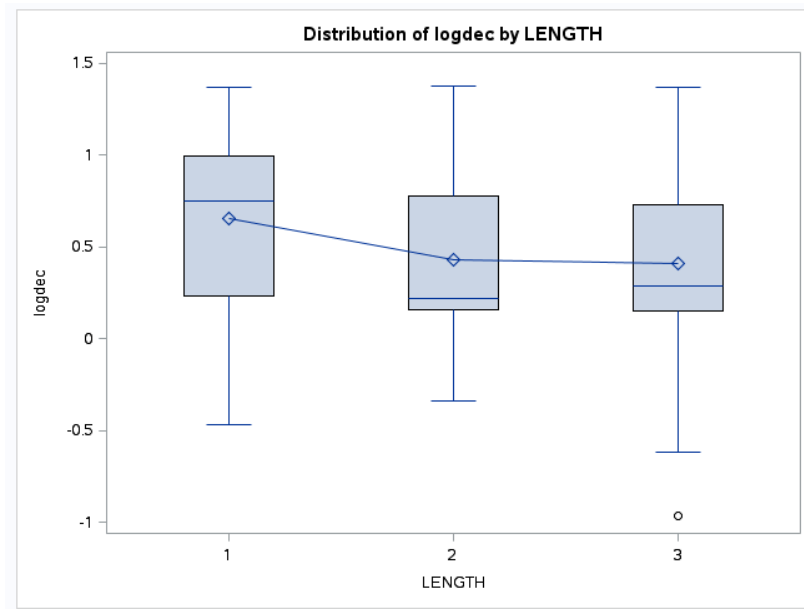

Relation between Log Standard Deviation of Deceleration and Pavement Markings Conditions at zone 2

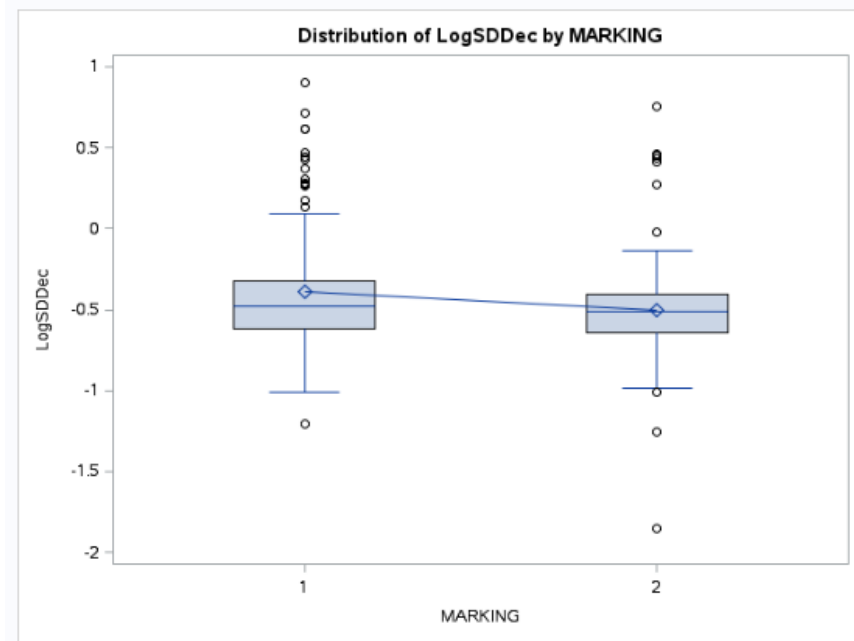

Relation between Log Standard Deviation of Deceleration and Age Groups at zone 1

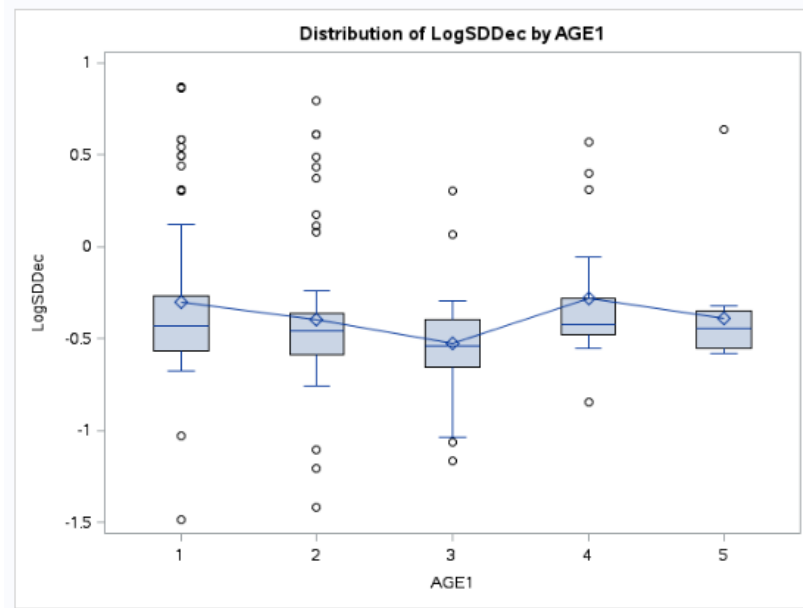

### Relation between Log Standard Deviation of Deceleration and Gender at zone 1

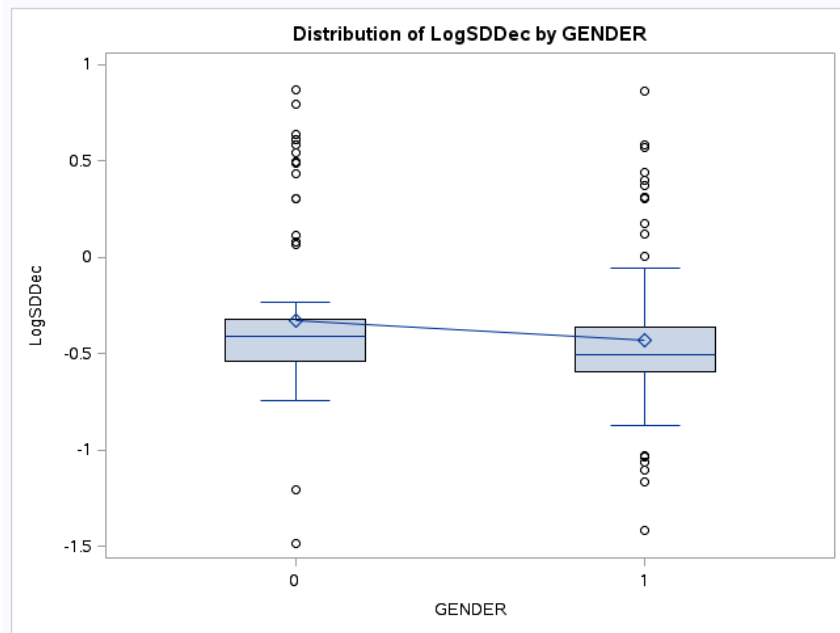

## LIST OF REFERENCES

- Abdel-Aty, M., and Radwan, E. (2000). Modeling traffic accident occurrence and involvement. *Accident Analysis & Prevention*, Vol. 32, No. 5, pp. 633–642.
- Abdel-Aty, M., Yan, X., Radwan, E., Harris, G., and Klee, H. (2006). Using the UCF Driving Simulator as a Test Bed for High Risk Locations, Final Report submitted to Florida Department of Transportation, University of Central Florida.
- Abdelwahab, H., and Abdel-Aty, M. (2002). Artificial Neural Networks and Logit Models for Traffic Safety Analysis of Toll Plazas. In *Transportation Research Record: Journal of the Transportation Research Board*, No. 1784, Transportation Research Board of the National Academies, Washington, D.C., pp. 115–125.
- Abuzwidah, M. (2011) Evaluation and Modeling of the Safety of Open Road Tolling System, Thesis, University of Central Florida, Orlando, FL.
- Abuzwidah, M. (2014) Traffic Safety Assessment of Different Toll Collection Systems On Expressways Using Multiple Analytical Techniques, Dissertation, University of Central Florida, Orlando, FL.
- Abuzwidah, M., and Abdel-Aty, M. (2015). Safety assessment of the conversion of toll plazas to all-electronic toll collection system. *Accident Analysis & Prevention*, Vol. 80, pp. 153–161.
- Al-Deek, H., and Mohamed, A. (2000). Simulation and evaluation of the Orlando-Orange County Expressway Authority (OOCEA) electronic toll collection plazas using TPSIM. Contract No. BC-096, Florida Dept. of Transportation (FDOT) Research Center, Tallahassee, FL.

- Allen, R., Rosenthal, T., and Cook, M., (2001). *A short history of driving simulation*. Taylor & Francis Group, LLC, FL.
- Bella, F (2005). Validation of a Driving Simulator for Work Zone Design. *Transportation Research Record: Journal of the Transportation Research Board*, No. 1937, pp. 136–144.
- Bella, F (2008). Driving simulator for speed research on two-lane rural roads. *Accident Analysis & Prevention*, Vol. 40, No. 3, pp. 1078–1087.
- Bham, G., Mathur, D., Leu, M., and Vallati., M., (2010). Younger driver’s evaluation of vehicle mounted attenuator markings in work zones using a driving simulator. *Transportation Letters*, Vol. 2, No. 3, pp. 187–198.
- Bham, G., Leu, M., Vallati, M., and Mathur, D., (2014). Driving simulator validation of driver behavior with limited safe vantage points for data collection in work zones. *Journal of safety research*, Vol. 49, pp. 53–e1.
- Blana, E., (1996). *A Survey of Driving Research Simulators Around the World*. Institute for Transport Studies, University of Leeds.
- Brown, L., McDonald Jr, D., and Myers, E., (2006). Developing traffic control strategies at toll plazas. *Institute of Transportation Engineers. ITE Journal*, Vol. 76, No. 11, 2006, p. 22-26.
- Carroll, K. (2016) Evaluation of Real World Toll Plazas Using Driving Simulation, Thesis, University of Central Florida, Orlando, FL.
- Central Florida Expressway Authority Standards for Preparation of Signing and Pavement Marking Plans



[https://www.cfxway.com/wpcontent/uploads/2015/12/CFX\\_Sign\\_Pavement\\_Std\\_Oct\\_2014.pdf](https://www.cfxway.com/wpcontent/uploads/2015/12/CFX_Sign_Pavement_Std_Oct_2014.pdf)

Chandraratna, S., and Stamatiadis, N., (2009). Quasi-induced exposure method: evaluation of not-at-fault assumption. *Accident Analysis & Prevention*, Vol. 41, No. 2, pp. 308–313.

Department of Transportation, 2009.

Evans, L. (2004). *Traffic Safety. Science Serving Society. Bloomfield Hills, MI*, pp. 70-77.

Frank, H., Casali J., and Wierwille, W., (1988). Effects of visual display and motion system delay on operator performance and uneasiness in a driving simulator. *Human Factors: The Journal of the Human Factors and Ergonomics Society*, Vol. 30, No. 2, pp. 201–217.

Godley, S., Triggs, T., and Fildes, B., (2002). Driving simulator validation for speed research. *Accident analysis & prevention*, Vol. 34, No. 5, pp. 589–600.

Haleem, Kirolos. (2007). Exploring the Potential of Combining Ramp Metering and Variable Speed Limit Strategies for Alleviating Real-Time Crash Risk on Urban Freeways. Thesis. University of Central Florida Orlando, Florida.

Harré, N., Field, J. and Kirkwood, B. (1996). Gender differences and areas of common concern in the driving behaviors and attitudes of adolescents. *Journal of Safety Research*, Vol. 27, No. 3, pp. 163–173.

Herman, R., Montroll, E., Potts R., and Rothery R., (1959). Traffic dynamics: analysis of stability in car following. *Operations research*, Vol. 7, No. 1, pp. 86–106.

Jones, T., and Potts, R., (1962). The measurement of acceleration noise-a traffic parameter. *Operations Research*, Vol. 10, No. 6, pp. 745–763.

- Ko, J., Guensler, R., and Hunter, M. (2010). Analysis of effects of driver/vehicle characteristics on acceleration noise using GPS-equipped vehicles. *Transportation research part F: traffic psychology and behaviour*, Vol. 13, No. 1, pp. 21–31.
- Lee, C., and Abdel-Aty, M. (2008). Testing effects of warning messages and variable speed limits on driver behavior using driving simulator. In *Transportation Research Record: Journal of the Transportation Research Board*, No. 2069, pp. 55–64.
- Lindstrom, M., and Bates, D. (1988). Newton Raphson and EM algorithms for linear mixed-effects models for repeated-measures data. *Journal of the American Statistical Association*, Vol. 83, No. 404, pp. 1014–1022.
- Manual on Uniform Traffic Control Devices for Streets and Highways. FHWA, U.S.  
<http://mutcd.fhwa.dot.gov/pdfs/2009r1r2/mutcd2009r1r2edition.pdf>. Accessed July 4, 2016.
- McKinnon, I. (2013) Operational and Safety-based Analyses of Varied Toll Lane Configurations, Thesis, University of Massachusetts Amherst, Amherst, MA.
- Mohamed, A., Abdel-Aty, M., and Klodzinski, J. (2001) Safety Considerations in Designing Electronic Toll Plazas: Case Study. *ITE journal*, Vol. 71, No. 3, pp. 20–33.
- Nilsson, L. (1993). Behavioural research in an advanced driving simulator-experiences of the VTI system. *Proceedings of the Human Factors and Ergonomics Society 37<sup>th</sup> Annual Meeting*, No. 37, pp. 612–616.
- Reed, M., and Green, P., (1999). Comparison of driving performance on-road and in a low cost simulator using a concurrent telephone dialing task, *Ergonomics*, 42 (1991), pp. 1015-1037

- Rephlo, J., Carter, M., Robinson, M., Katz, B., and Philmus, K. (2010). Toll Facilities Workplace Safety Study Report to Congress. Publication FHWA-IF-08-001. FHWA, U.S. Department of Transportation.
- Shi, Q., and Abdel-Aty M. (2015). Big data applications in real-time traffic operation and safety monitoring and improvement on urban expressways. *Transportation Research Part C: Emerging Technologies*, Vol. 58, pp. 380–394.
- Stamatiadis, N., and Deacon J. (1997). Quasi-induced exposure: methodology and insight. *Accident Analysis & Prevention*, Vol. 29, No. 1, pp. 37–52.
- Valdés, D., Colucci, B., Fisher, D., Ruiz, J., Colón, E., and García R. (2016). Driving Simulation in the Safety and Operation Performance of the Freeway Toll Plaza. Presented at Transportation Research Board 95<sup>th</sup> Annual Meeting, Washington, DC.
- Zeger, S., and Karim, M. (1991). Generalized linear models with random effects; a Gibbs sampling approach. *Journal of the American statistical association*, Vol. 86, No. 413, pp. 79–86.